

Münevver YENİGÜL

A Master's Thesis

AGU 2022

THE EFFECT OF HISTONE  
DEACETYLASE INHIBITION AND  
AUTOPHAGY MODULATION ON THE  
CHOLANGIOCARCINOMA CELLS

A THESIS

SUBMITTED TO THE DEPARTMENT OF BIOENGINEERING  
AND THE GRADUATE SCHOOL OF ENGINEERING AND SCIENCE  
OF ABDULLAH GUL UNIVERSITY  
IN PARTIAL FULFILLMENT OF THE REQUIREMENTS  
FOR THE DEGREE OF  
MASTER OF SCIENCE

By

Münevver Yenigül

June 2022

THE EFFECT OF HISTONE DEACETYLASE  
INHIBITION AND AUTOPHAGY MODULATION  
ON THE CHOLANGIOCARCINOMA CELLS

A THESIS

SUBMITTED TO THE DEPARTMENT OF BIOENGINEERING  
AND THE GRADUATE SCHOOL OF ENGINEERING AND SCIENCE OF  
ABDULLAH GUL UNIVERSITY

IN PARTIAL FULFILLMENT OF THE REQUIREMENTS  
FOR THE DEGREE OF  
MASTER

By

Münevver Yenigül

June, 2022

## SCIENTIFIC ETHICS COMPLIANCE

I hereby declare that all information in this document has been obtained in accordance with academic rules and ethical conduct. I also declare that, as required by these rules and conduct, I have fully cited and referenced all materials and results that are not original to this work.

Name-Surname: Münevver Yenigül

Signature :



## REGULATORY COMPLIANCE

M.Sc. thesis titled “The Effect of Histone Deacetylase Inhibition and Autophagy Modulation on the Cholangiocarcinoma Cells” has been prepared in accordance with the Thesis Writing Guidelines of the Abdullah Gül University, Graduate School of Engineering & Science.

Prepared By  
Münevver  
Yenigül  
Signature

Advisor  
Assist. Prof. Dr. Emel Başak  
Gencer Akçok  
Signature

Co-Advisor  
Assist. Prof. Dr. İsmail  
Akçok  
Signature

Head of the Bioengineering Program  
Prof. Dr. Sevil Dinçer İšođlu  
Signature

## ACCEPTANCE AND APPROVAL

M.Sc. thesis titled “The Effect of Histone Deacetylase Inhibition and Autophagy Modulation on the Cholangiocarcinoma Cells” and prepared by Münevver YENİGÜL has been accepted by the jury in the Bioengineering Graduate Program at Abdullah Gül University, Graduate School of Engineering & Science.

21/06/2022

(Thesis Defense Exam Date)

### JURY:

Advisor: Assist. Prof. Dr. Emel Başak GENCER AKÇOK.....

Member: Prof. Dr. Servet ÖZCAN.....

Member: Assist. Prof. Dr. Şerife AYAZ GÜNER.....

Co-Advisor: Assist. Prof. Dr. İsmail AKÇOK.....

### APPROVAL:

The acceptance of this M.Sc. thesis has been approved by the decision of the Abdullah Gül University, Graduate School of Engineering & Science, Executive Board dated ..... /..... / ..... and numbered .....

..... /..... / .....

**(Date)**

Graduate School Dean  
Prof. Dr. İrfan ALAN

ABSTRACT

THE EFFECT OF HISTONE DEACETYLASE INHIBITION  
AND AUTOPHAGY MODULATION ON THE  
CHOLANGIOCARCINOMA CELLS

Münevver Yenigül  
MSc in Bioengineering  
Advisor: Assist. Prof. Dr. Emel Başak Gencer Akçok

June 2022

Cholangiocarcinoma (CCA), also known as biliary tract cancer, is a heterogeneous group of malignancies formed by the differentiation of epithelial cells in the biliary tract. CCA is the second most common primary liver tumor and it has both an increasing rate and high mortality worldwide with its late diagnosis, refractory type, and aggressiveness. The effects of autophagy modulators and HDAC inhibitors in CCA are not fully known. This study is proposed a novel treatment approach with the combinational therapy of autophagy and HDAC inhibitors for CCA patients. In results obtained with alone HDACis, alone autophagy modulators, and combinations of HDACis and autophagy modulators, Nocodazole from autophagy modulators and MS-275 and Romidepsin from HDAC inhibitors showed a better synergistic effect on the TFK-1 and EGI-1 cell lines of the cholangiocarcinoma. In cell cycle analysis of the combination, was achieved arrest at the S phase and G2/M phase. In conclusion, this study highlights the important combination of HDAC inhibitors and autophagy modulators, which is a promising therapy in CCA.

*Keywords: Cholangiocarcinoma, HDAC inhibitors, Autophagy modulators, Combination therapy*

ÖZET

HİSTON DEASETİLAZ İNHİBİSYONU VE OTOFAJİ  
MODÜLASYONUNUN KOLANJİOKARSİNOMA  
HÜCRELERİNE ETKİSİ

Münevver Yenigül  
Biyomühendislik Anabilim Dalı Yüksek Lisans  
Tez Yöneticisi: Dr. Öğr. Üyesi Emel Başak Gencer Akçok  
Haziran-2022

Safra yolu kanseri olarak da bilinen kolanjiokarsinom (CCA), safra yollarındaki epitel hücrelerinin farklılaşmasıyla oluşan heterojen bir malignite grubudur. CCA, ikinci en sık görülen primer karaciğer tümörüdür ve geç tanısı, refrakter tipi ve agresifliği ile dünya çapında hem artan orana hem de yüksek mortaliteye sahiptir. Otofaji modülatörlerinin ve HDAC inhibitörlerinin CCA'daki etkileri tam olarak bilinmemektedir. Bu çalışma, CCA hastaları için otofaji ve HDAC inhibitörlerinin kombinasyonel tedavisi ile yeni bir tedavi yaklaşımı önermektedir. Kolanjiokarsinoma hücre hatları olan TFK-1 ve EGI-1 hücre hatları üzerinde HDAC inhibitörleri, otofaji modülatörleri ve HDAC inhibitörleri ile otofaji modülatörlerinin kombinasyonlarıyla elde edilen sonuçlarda, otofaji modülatörlerinden Nocodazole ve HDAC inhibitörlerinden MS-275 ve Romidepsin daha iyi bir sinerjistik etki gösterdi. Kombinasyonun hücre döngüsü analizinde, S fazında ve G2/M fazında baskılama sağlandı. Sonuç olarak, bu çalışma, CCA'da umut verici bir tedavi olan HDAC inhibitörleri ve otofaji modülatörlerinin önemli kombinasyonunu vurgulamaktadır.

*Anahtar kelimeler: Kolanjiokarsinoma, HDAC inhibitörleri, Otofaji modülatörleri, Kombinasyon terapisi*

# Acknowledgements

First of all, I would like to express my sincere thanks to my advisor Assist. Prof. Dr. Emel Bařak GENCER AKÇOK for supporting and understanding me academically and for being a role model with her knowledge and humanity.

I would like to thank my co-advisor Assist. Prof. Dr. İsmail AKÇOK for supporting and understanding me academically.

I would like to express my thanks to my jury committee members Prof. Dr. Servet ÖZCAN and Assist. Prof. Dr. řerife AYZAZ GÜNER for their suggestions and comments and also, thanks Assist. Prof. Dr. Mona El KHATİB for support this study.

I would like to thank my dear friends Osman Oğuz for their help, support, and friendship during this research. And thank you so much my dear friends Fulya Mina Küçüktař, Enes Çiçek, Zeynep řenel, and Nur řebnem Ersöz their supportive friendship.

I also would like to also thank Esmā Saraymen for her technical assistance and information during flow cytometry measurements.

I would like to thank my family Nursel, Nusret, Kerem, H. Yusuf, İlayda, A. Reyyan, and A. Musab and also my grandmother, aunts, uncles, and cousins for their limitless support.

Finally, I would like to thank Prof. Dr. Yusuf Baran for introducing me with my advisor.

This thesis is financially supported by TÜBİTAK (project no: 217S660) within the context of the “National Young Researches Career Development Program”.

Münevver YENİGÜL



# TABLE OF CONTENTS

<b>1. INTRODUCTION .....</b>	<b>1</b>
1.1 CHOLANGIOCARCINOMA .....	2
1.1.1 <i>Intrahepatic Cholangiocarcinoma</i> .....	3
1.1.2 <i>Extrahepatic Cholangiocarcinoma</i> .....	3
1.2 EPIGENETICS AND ITS REGULATORS .....	5
1.2.1 <i>DNA Methylation</i> .....	7
1.2.2 <i>Histone Modification</i> .....	8
1.2.3 <i>Histone Acetylation</i> .....	8
1.3 HDAC INHIBITORS .....	11
1.4 AUTOPHAGY .....	12
<b>2. MATERIAL AND METHOD .....</b>	<b>18</b>
2.1 MAINTENANCE OF CELL LINES .....	18
2.2 DRUG PREPARATION .....	18
2.3 CELL VIABILITY ASSAY .....	19
2.3.1 <i>Combinations of HDACis and Autophagy Modulators</i> .....	19
2.3.2 <i>Calculation of CI (Combination Index)</i> .....	20
2.4 ANALYSIS OF CELL CYCLE DISTRIBUTION .....	21
2.5 FLOW CYTOMETRIC DETECTION OF APOPTOSIS BY ANNEXIN-V FITC / PROPIDIUM IODIDE DUAL STAINING .....	21
2.6 WESTERN BLOT ANALYSIS .....	22
2.7 STATISTICAL ANALYSIS .....	23
<b>3. RESULTS .....</b>	<b>24</b>
3.1 THE EFFECT OF HDAC INHIBITION TREATMENT ON THE PROLIFERATION OF CCA AND HCC CELL LINES.....	24
3.2 THE EFFECT OF AUTOPHAGY MODULATORS TREATMENT ON THE PROLIFERATION OF CCA AND HCC CELL LINES.....	29
3.3 THE EFFECT OF COMBINATION TREATMENT OF HDAC INHIBITORS AND AUTOPHAGY MODULATORS ON THE PROLIFERATION OF CHOLANGIOCARCINOMA CELL LINES .....	33

3.4 THE COMBINATION TREATMENT OF THE IC <sub>30</sub> VALUES HDAC INHIBITORS AND AUTOPHAGY MODULATORS AND ITS EFFECT ON THE PROLIFERATION OF CHOLANGIOCARCINOMA CELL LINES.....	39
3.5 THE SYNERGISTIC EFFECTS OF THE COMBINATIONS OF THE NOCODAZOLE – HDAC INHIBITORS .....	47
3.6 CYTOSTATIC EFFECTS OF SINGLE NOCODAZOLE AND IN COMBINATION WITH HDAC INHIBITORS ON CCA CELLS .....	50
3.7 APOPTOTIC EFFECTS OF COMBINATION NOCODAZOLE AND HDACIS ON CCA .....	53
3.8 HDACIS AND NOCODAZOLE COMBINATIONS INDUCED THE ACETYLATION AND HDAC LEVELS IN CCA CELLS.....	55
<b>4. CONCLUSION AND FUTURE PROSPECTS .....</b>	<b>58</b>
4.1 CONCLUSIONS .....	58
4.2 SOCIETAL IMPACT AND CONTRIBUTION TO GLOBAL SUSTAINABILITY .....	61
4.3 FUTURE PROSPECTS.....	62

# LIST OF FIGURES

Figure 1.1 Schematic diagram cellular differentiation relations between primary liver carcinoma. PLC: Primary Liver Carcinoma, HCC: Hepatocellular carcinoma, iCCA: intrahepatic cholangiocarcinoma, CCA: Cholangiocarcinoma, cHCC: combined hepatocellular carcinoma (Adapte from [11]) .....	2
Figure 1.2 Classification of the bile duct (cholangiocarcinoma) anatomically .....	3
Figure 1.3 Epigenetic modifications are examined in three main groups. nc-RNA: noncoding RNA, dsRNA: double strand RNA, miRNA: microRNA .....	6
Figure 1.4 Genomic changes of epigenetic regulations in cholangiocarcinoma patients..	6
Figure 1.5 HAT (Histone Acetyltransferase) and HDAC (Histone Deacetylase) are balance of histone acetylation on gene expression. HDACi (Histone Deacetylase inhibitor) inhibits HDAC .....	9
Figure 1.6 Schematic representation of structural classes and target selectivity of histone deacetylase inhibitors (HDACis). NAD <sup>+</sup> , nicotinamide; Zn <sup>2+</sup> , zinc.....	11
Figure 1.7 Three different mechanisms of autophagy [128] .....	14
Figure 1.8 Autophagy occurs from stages initiation, nucleation, elongation, maturation, fusion, and degradation [135] .....	15
Figure 3.1 The effect of SAHA(a), PCI-34051(b), MS-275(c), Romidepsin(d), Tubastatin A(e) treatment on the proliferation of TFK-1 cells for 48h.....	25
Figure 3.2 The effect of SAHA(a), PCI-34051(b), MS-275(c), Romidepsin(d), Tubastatin A(e) treatment on the proliferation of TFK-1 cells for 48h (n=3).....	27
Figure 3.3 The effect of SAHA(a), Romidepsin(b), MS-275(c), treatment on the proliferation of HepG2 cells for 48h (n=3).....	28
Figure 3.4 The effect of Vinblastine (a), PP242 (b), Chloroquine (c), Nocodazole (d), Ammonium chloride (e) treatment on the proliferation of TFK-1 cells for 48h (n=3). .	30
Figure 3.5 The effect of Vinblastine (a), PP242 (b), Chloroquine (c), Nocodazole (d), Ammonium chloride (e) treatment on the proliferation of EGI-1 cells for 48h (n=3). ..	31
Figure 3.6 The effect of Chloroquine(a), PP242 (b), Nocodazole (c), treatment on the proliferation of HepG2 cells for 48h (n=3).....	32
Figure 3.7 The combination treatment of constant IC <sub>30</sub> values of HDAC inhibitors with increasing doses of autophagy modulators were applied on the TFK-1 cell for 48h (n=3). The combinations of Chloroquine doses and a) SAHA IC <sub>30</sub> (2.25 μM), b) MS-275 IC <sub>30</sub>	

(3.5 nM) c) Romidepsin IC30 (3.7 nM), respectively. The combinations of Nocodazole and d) SAHA IC30 (2.25  $\mu$ M), e) MS-275 IC30 (3.5 nM) f) Romidepsin IC30 (3.7 nM), respectively. The combinations of the PP242 and g) SAHA IC30 (2.25  $\mu$ M), h) MS-275 IC30 (3.5 nM) i) Romidepsin IC30 (3.7 nM), respectively..... 35

Figure 3.8 The combination treatment of constant IC30 values of HDAC inhibitors and increasing doses of autophagy modulators were applied on the EGI-1 cell for 48h (n=3). The combinations of Chloroquine doses and a) SAHA IC30 (0.43  $\mu$ M), b) MS-275 IC30 (0.53 nM) c) Romidepsin IC30 (0.74 nM), respectively. The combinations of Nocodazole and d) SAHA IC30 (0.43  $\mu$ M), e) MS-275 IC30 (0.53 nM) f) Romidepsin IC30 (0.74 nM), respectively. The combinations of PP242 and g) SAHA IC30 (0.43  $\mu$ M), h) MS-275 IC30 (0.53 nM), i) Romidepsin IC30 (0.74 nM), respectively. .... 37

Figure 3.9 The combination treatment of constant IC30 values of HDAC inhibitors and increasing doses of autophagy modulators were applied on the HepG2 cell for 48h (n=3). The combinations of Chloroquine doses and a) SAHA IC30 (1.2  $\mu$ M), b) MS-275 IC30 (4.3 nM) c) Romidepsin IC30 (0.94 nM), respectively. The combinations of Nocodazole doses and d) SAHA IC30 (1.2  $\mu$ M), e) MS-275 IC30 (4.3 nM) f) Romidepsin IC30 (0.94 nM), respectively. The combinations of PP242 doses and g) SAHA IC30 (1.2  $\mu$ M), h) MS-275 IC30 (4.3 nM), i) Romidepsin IC30 (0.94 nM), respectively..... 39

Figure 3.10 The combination treatment of IC30 values of HDAC inhibitors and of autophagy modulators for TFK-1 cell for 48h (n=3). The combinations of the Chloroquine IC30 (3.94  $\mu$ M) and a) SAHA IC30 (2.25  $\mu$ M), b) MS-275 IC30 (3.5 nM) c) Romidepsin IC30 (3.7 nM), respectively. The combinations of the Nocodazole IC30 (2.89  $\mu$ M) and d) SAHA IC30 (2.25  $\mu$ M), e) MS-275 IC30 (3.5 nM) f) Romidepsin IC30 (3.7 nM), respectively. The combinations of the PP242 IC30 (1.1 nM) and g) SAHA IC30 (2.25  $\mu$ M), h) MS-275 IC30 (3.5 nM) i) Romidepsin IC30 (3.7 nM), respectively.....41

Figure 3.11 The combination treatment of constant IC30 values of HDAC inhibitors and increasing doses of autophagy modulators for EGI-1 cell for 48h (n=3). The combinations of the Chloroquine IC30 (5.14  $\mu$ M) and a) SAHA IC30 (0.43  $\mu$ M), b) MS-275 IC30 (0.53 nM) c) Romidepsin IC30 (0.74 nM), respectively. The combinations of the Nocodazole IC30 (2.15  $\mu$ M) and d) SAHA IC30 (0.43  $\mu$ M), e) MS-275 IC30 (0.53 nM) f) Romidepsin IC30 (0.74 nM), respectively. The combinations of the PP242 IC30 (9.02 nM) and g) SAHA IC30 (0.43  $\mu$ M), h) MS-275 IC30 (0.53 nM), i) Romidepsin IC30 (0.74 nM), respectively..... 43

Figure 3.12 The combination treatment of constant IC30 values of HDAC inhibitors and increasing doses of autophagy modulators for HepG2 cell for 48h (n=3). The combinations of the Chloroquine IC30 (4.1 $\mu$ M) and a) SAHA IC30 (1.2 $\mu$ M), b) MS-275 IC30 (4.3 nM) c) Romidepsin IC30 (0.94 nM), respectively. The combinations of sthe Nocodazole IC30 (4.7 $\mu$ M) and d) SAHA IC30 (1.2 $\mu$ M), e) MS-275 IC30 (4.3 nM) f) Romidepsin IC30 (0.94 nM), respectively. The combinations of the PP242 IC30 (4.4 $\mu$ M) and g) SAHA IC30 (1.2 $\mu$ M), h) MS-275 IC30 (4.3 nM), i) Romidepsin IC30 (0.94 nM),respectively.....	45
Figure 3.13 Combination Index (CI) Plots of TFK-1 (a, b, c) and EGI-1 (d, e, f) cell lines treated with combination increased doses of the nocodazole with HDACis. a, d) MS-275: nocodazole, b, e) SAHA: nocodazole, c, f) Romidepsin: nocodazole.....	50
Figure 3.14 Cell cycle distributions of (a) MS-275 IC30 - Nocodazole IC30, (b) Romidepsin IC30 – Nocodazole IC30, and (c) SAHA IC30 – Nocodazole IC30 combinations in TFK-1 cells for 48h (n=2).....	51
Figure 3.15 Cell cycle distributions of (a) MS-275 IC30 - Nocodazole IC30, (b) Romidepsin IC30 – Nocodazole IC30, and (c) SAHA IC30 – Nocodazole IC30 combinations in EGI-1 cells for 48h (n=2).....	52
Figure 3.16 Apoptotic effects of Romidepsin - Nocodazole (a) and MS-275 Nocodazole (b) on TFK-1 cells (n=2).....	54
Figure 3.17 Apoptotic effects of Romidepsin - Nocodazole (a) and MS-275 Nocodazole (b) on TFK-1 cells (n=2).....	55
Figure 3.18 Changes in AcH3/H4, total H3/H4, and HDAC 1 / 2 (a) in TFK-1, (b) in EGI-1 cells. Gapdh was used as a loading control. Experiments were replicated independently (n=2) and a representative western blot image was used for each set. The protein expression of each group was normalized to their Gapdh. ....	57

# LIST OF TABLES

Table 1.1 Autophagy modulators.....	17
Table 2.1 IC <sub>30</sub> values of the HDAC inhibitors and autophagy modulators on the TFK-1 and EGI-1 cell lines. ....	20
Table 3.1 IC <sub>30</sub> , and IC <sub>50</sub> values of the HDAC inhibitors on the TFK-1, EGI-1 ve HepG2 cell lines. ....	28
Table 3.2 IC <sub>30</sub> , and IC <sub>50</sub> values of the autophagy modulators on the TFK-1, EGI-1 ve HepG2 cell lines.....	32
Table 3.3 The percentage of the cell proliferation of the IC30 combinations on TFK-1, EGI-1 and HepG2 cell lines. On the table identified as MS-275 alone, SAHA alone, and Romidepsin alone the orange color, Chloroquine alone, Nocodazole alone, and PP242 alone the green color, and combination of IC30 HDACis and IC30 autophagy modulators the blue color.. ....	47

# LIST OF ABBREVIATIONS

ATG	Autophagy-related gene
CCA	Cholangiocarcinoma
cCCA	Combined hepatocellular carcinoma
dCCA	Distal Cholangiocarcinoma
DATS	Diallyl trisulfide
eCCA	Extrahepatic Cholangiocarcinoma
HAT	Histone acetyltransferase
Hb	Hydroxamate-based
hCCA	Hilar Cholangiocarcinoma
HCC	Hepatocellular Carcinoma
HDAC	Histone deacetyltransferase
HDACi	Histone Deacetylase inhibitor
iCCA	Intrahepatic Cholangiocarcinoma
NAD <sup>+</sup>	Nicotinamide
pCCA	Perihilar Cholangiocarcinoma
PI3P	Phosphatidyl inositol 3-phosphate
PLC	Primary liver carcinoma
PTCL	peripheral T-cell lymphomas
SCFA	Short-chain fatty acid
SphK	sphingosine kinase 2 inhibitor
Zn <sup>2+</sup>	Zinc



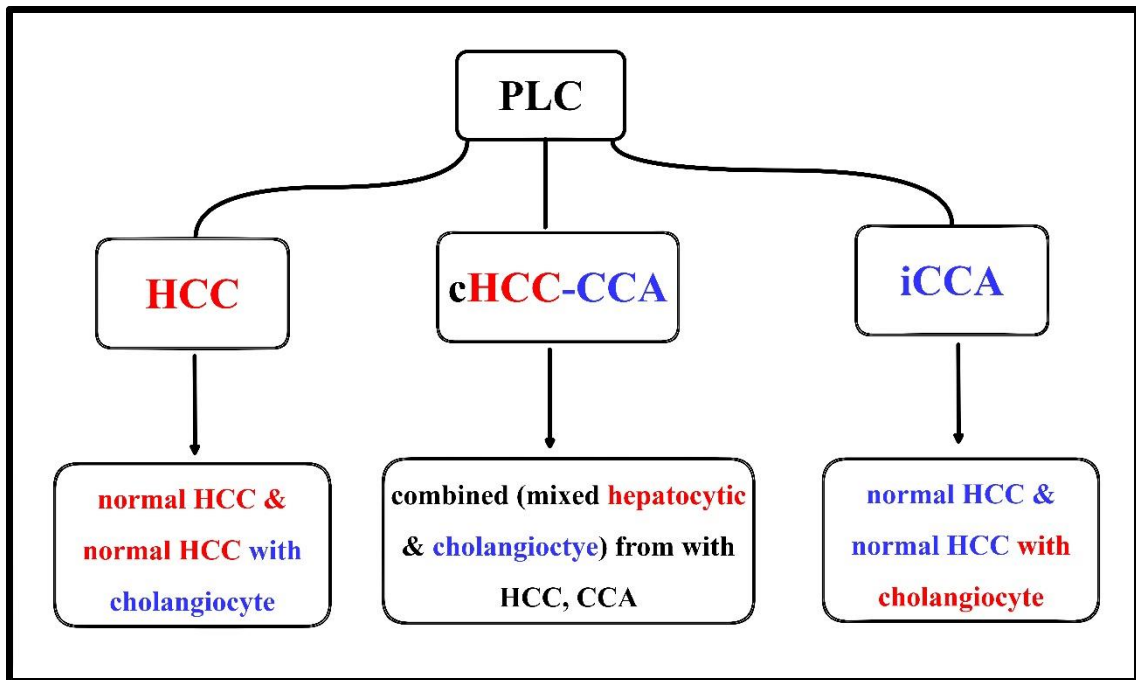
*To my grandfather, Mehmet Ali Yenigül*



# Chapter 1

## Introduction

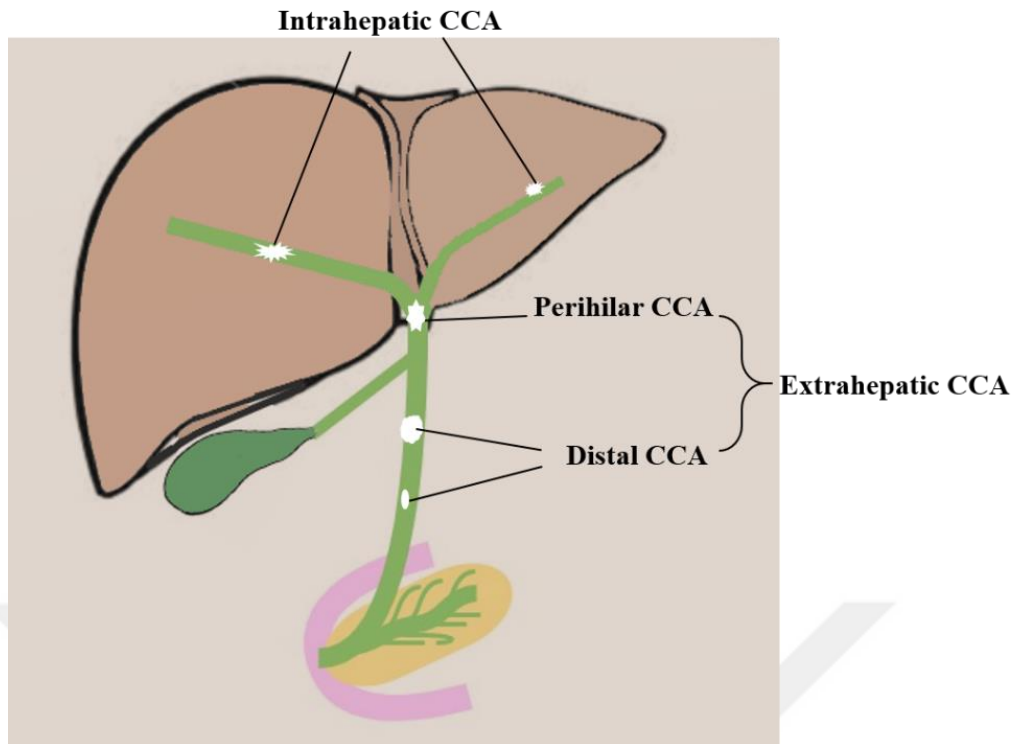
Cancer is the definition of a disease generated by the caused irregular proliferation of cells with the accumulation of DNA damages in the normal cells that it is a disease that reduces the quality of life is a major cause of death [1,4]. It has the highest death rate around the world after the cardiovascular disease [5]. In cancer, it has been stated that there are more than 277 and different kinds of cancer types [6]. In particular, the rate of incidence of cancer types is changing by gender and different age groups. In general, cancer types such as lung, liver, stomach, breast, and prostate are frequently seen [7]. Among them, liver cancer is the fifth-order around the world but it is the third most common among those who died of cancer [8]. The primary tumor of the liver that usually occurs in cirrhosis, viral hepatitis, extreme alcohol intake, and chronic liver disease is hepatocellular carcinoma (HCC) [9]. PLC (Primary liver cancer) is the second most common in cancer-related die in the World [10]. Actually, the liver is an organ mainly composed of special cells called hepatocytes. Terminologically, primary liver carcinomas have been named hepatocellular-cholangiocarcinoma because of the mixed or combined presence of both hepatocytes and differentiated cholangiocytes cells (Figure 1.1) [11]. And primary liver cells create a heterogeneous histopathologic spectrum, including HCC, hepatocellular-cholangiocarcinoma, and intrahepatic cholangiocarcinoma (iCCA) [12]. We will consider the type of cholangiocarcinoma cancer that occurs with the differentiation of HCCs throughout this thesis study.



**Figure 1.1 Schematic diagram cellular differentiation relations between primary liver carcinoma. PLC: Primary Liver Carcinoma, HCC: Hepatocellular carcinoma, iCCA: intrahepatic cholangiocarcinoma, CCA: Cholangiocarcinoma, cHCC: combined hepatocellular carcinoma (Adapte from [11]).**

## **1.1 Cholangiocarcinoma**

Cholangiocarcinoma (CCA), also known as biliary tract cancer, is a heterogeneous group of malignancies formed by the differentiation of epithelial cells in the biliary tract [13,15]. CCA is the second most common primary liver tumor and it has both an increasing rate and high mortality worldwide with its late diagnosis, refractory type, and aggressiveness [14]. Bile ducts are ducts through which bile is transported. These channels carry the bile from the liver to the gallbladder and then transfer to the duodenum (small intestine) from the biliary tract [16]. Anatomically, the bile ducts are divided into intrahepatic or extrahepatic (Figure 1.2) [17]. Intrahepatic cholangiocarcinoma (iCCA) is a type of cancer consisting of epithelial cells of the distal branch bile duct located in the inner part of the liver [18,19]. Extrahepatic cholangiocarcinoma (eCCA) is a type of cancer that occurs in the outer part of the liver [24].



**Figure 1.2 Classification of the bile duct (cholangiocarcinoma) anatomically.**

### **1.1.1 Intrahepatic Cholangiocarcinoma**

Intrahepatic cholangiocarcinoma (iCCA) is a type of cancer consisting of epithelial cells of the distal branch bile duct located in the inner part of the liver, and the majority of the cases are adenocarcinoma as known malignant tumors [18,19].

It is the second most common primary tumor and account for approximately 10% to 20% of all CCAs [19,20].

In fact, it is a type of cancer that is difficult to diagnose for has no specific symptoms. However, narrowing and thickening of the bile ducts were observed in patients of iCCA [21]. Surgical treatment is currently considered the only potentially curative treatment, but the five-year survival rate, including resected patients, is less than 5% [22,23].

### **1.1.2 Extrahepatic Cholangiocarcinoma**

Extrahepatic cholangiocarcinoma (eCCA) is a type of cancer that occurs in the outer part of the liver [24]. eCCA's constitute a large proportion of CCA's and occur in

two different regions of the bile duct called hilar CCA (hCCA) and distal CCA (dCCA) [25]. While hilar cholangiocarcinoma occurs within 2 cm of the hepatic duct bifurcation at the end of the liver, distal cholangiocarcinoma (dCCA) occurs outside the liver [26,29].

**a. Hilar Cholangiocarcinoma**

Hilar cholangiocarcinoma (hCCA), also known as perihilar (pCCA) or Klatskin, occurs within 2 cm of the hepatic duct bifurcation at the end of the liver [26]. The majority of eCCA's are approximately 60% to 70% hCCAs [27]. Morphologically, they are classified as exophytic, mass-forming, and intraductal types. There are three subtypes of intraductal pCCA: mass pCCA, periductal infiltrate, and nodular pCCA. The most common of these is periductal infiltrate. Intraductal tubulopapillary tumor is found with a better prognosis compared to the exophytic type pCCA [28].

**b. Distal Cholangiocarcinoma**

Distal cholangiocarcinoma (dCCA) is another type of cancer that occurs outside the liver and develops in the part of the biliary tract close to the small intestine and is in close association with the pancreas [29]. Patients with cancer of the distal biliary tract are occurring throughout the common bile duct between the cystic duct and ampulla of Vater but it differs clearly from ampullary carcinomas [30]. For this reason, cancers of the distal bile ducts, pancreatic cancers, and ampulla of Vater with similar symptoms are also called periampullary tumors [31]. dCCA is histologically well to moderately differentiated adenocarcinoma [30]. dCCAs, which make up 30% to 40% of eCCAs, present similarly to pCCAs and cause symptoms of cholangitis and cholestasis [30,32]. Also, lymph node metastases are less common than pCCA [30].

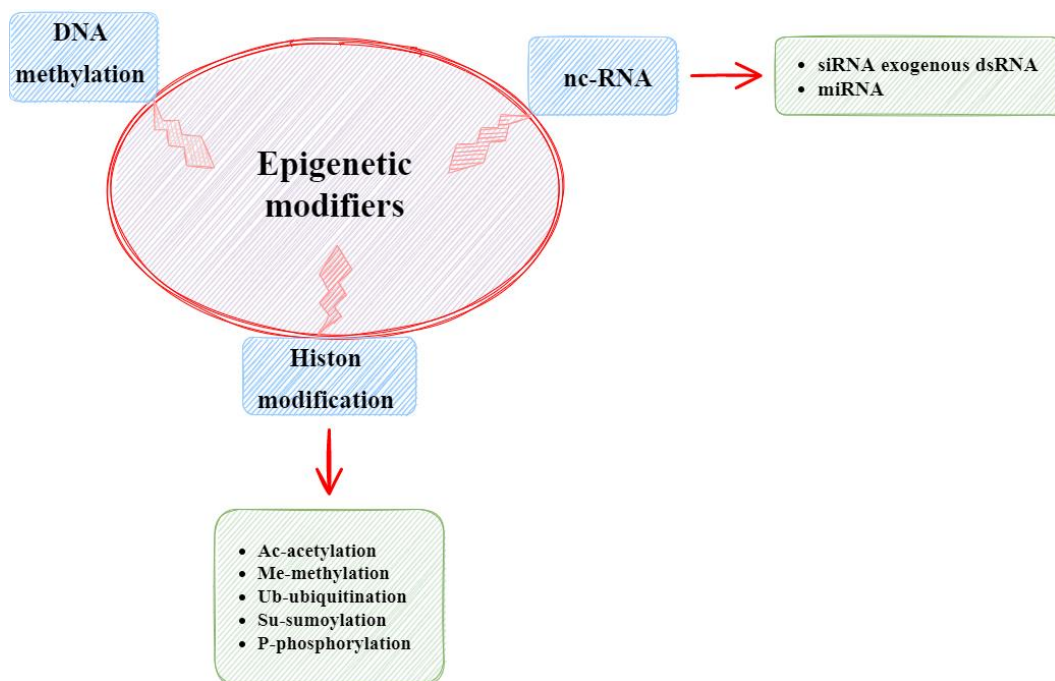
The slowly progressing nature of CCA makes it difficult to diagnose [33]. Since it is usually diagnosed in advanced stages, the surgical resection which is the only treatment option can be applied to the patients [34]. It is accepted that treatments such as radiotherapy, chemotherapy, and photodynamic therapy, improve the quality of life of patients however, CCA rarely responds to the treatments and progresses with a poor prognosis [33,35]. Therefore, new treatment strategies are needed. Actually, the main problem in these therapies is the resistance of CCA to treatment [36]. Systemic chemotherapy with cisplatin and gemcitabine is standard practice in these patients, but

more effective treatments are needed. New combinations with target drugs continue to be tested in clinical trials [37].

Cancer originates from the accumulation of genetic and epigenetic changes within the cell [38]. New approaches that are targeting epigenetic mechanisms besides existing treatments have been accepted and under investigation in the field of oncology with their successful clinical application and there is hope for new treatments [37,39]. One of the aims of this study is to treat and understand the impact of histone modifications on the CCA.

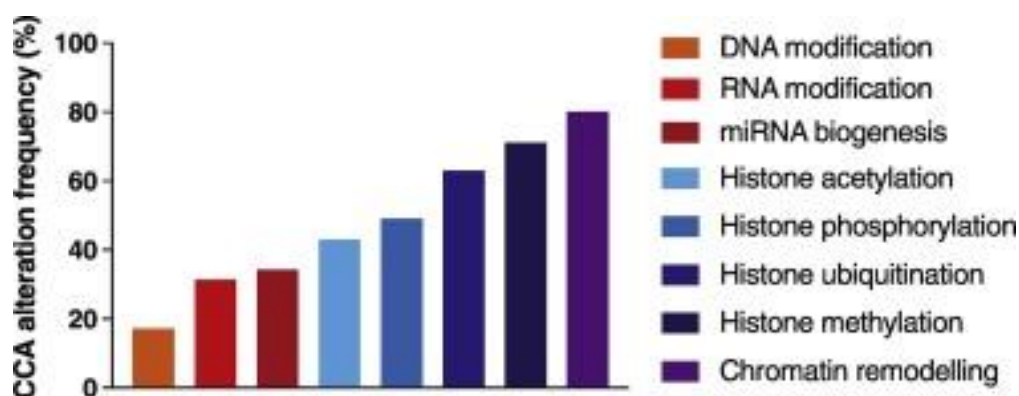
## **1.2 Epigenetics and its regulators**

Genetics is directly focused on how the differences in the cells occur and thus how the individuals are formed [39]. While the genes are transferred from the parents, it has been considered that the stress from the experiences of the parents can pathologically affect the offspring and a few generations. However, the cause of the occurring phenomena could not be determined [42]. To understand this situation, they turned to the concept of epigenetics, which was first introduced by Conrad Waddington in the 1940s [43]. The area of epigenetic studies the change in gene expression that become inherited by making structural changes in histones by indirectly interfering without changing the DNA sequence [44]. Although it forms a hereditary change, the changes that occur could be reversed [47]. Epigenetic modifications are examined in three main groups as DNA methylation, histone modifications, and non-coding RNA (Figure 1.3) [48]. DNA methylation is characterized by the formation of 5-methyl cytosine (5m-C) structure by attaching a methyl group (-CH<sub>3</sub>) to the 5<sup>th</sup> carbon of the cytosine (C) base [49]. Histones are basic proteins that package DNA and some post-translational modifications such as phosphorylation, ubiquitination, methylation, acetylation, sumoylation occur in all histone proteins. These modifications have major roles such as DNA replication, DNA repair, transcriptional regulation, chromosome condensation, and alternative splicing [50]. These epigenetic modifications regulate the accessibility of DNA by changing the chromatin structure. They modulate the signs of different cell types, different developmental stages, cancer, and many different diseases in relation with these modifications [51]. The errors in epigenetic processes lead to an altered gene function and cellular neoplastic transformation. Also it precedes genetic changes and generally emerges at an initial phase of neoplastic development [52].



**Figure 1.3 Epigenetic modifications are examined in three main groups. nc-RNA: noncoding RNA, dsRNA: double strand RNA, miRNA: microRNA.**

Since 1990, epigenetic modifications have been recognized as important for the evolution of all cancer types [45]. In CCA cases generally the reason is unknown. But, it has been reported that epigenetic regulations lead to the development and improvement of CCA [53]. Also, epigenetic modifications have been shown to affect nearly all levels of epigenetic regulation in cholangiocarcinoma (Figure 1.4) [46].



**Figure 1.4 Genomic changes of epigenetic regulations in cholangiocarcinoma patients [46].**

### 1.2.1 DNA Methylation

DNA methylation is an epigenetic modification that plays an important role in gene expression and chromatin organization. It is the attachment of methyl groups (-CH<sub>3</sub>) to DNA bases after DNA has been synthesized. Cytosines which take place before guanines in the DNA chain are especially methylated [54,55]. It is formed by the covalent addition of a methyl (CH<sub>3</sub>) group to the 5th carbon of the cytosine ring [56]. CpG island constitutes 50-60% of the gene promoter regions. Most of the CpGs found in the human genome are in the methylated state [57]. This methylation has been associated with reduced transcriptional functions of genes with a CpG dinucleotide in the promoter region [58]. The CpG islands are usually unmethylated during development and tissue differentiation [57].

In DNA methylation, S-adenosine is used as a methionine methyl donor. The methionine is transferred to the 5. region of cytosine through DNA methyltransferase enzymes [59]. The methylation that occurs in the promoter region of the gene suppresses the binding of transcription factors and therefore, the expression of the gene is suppressed. Repressor proteins bind to methylated DNA, causing repression of transcription [60]. DNA methylation is regulated by the enzyme family called DNA methyltransferases: DNMT1, DNMT2, DNMT3a, DNMT3b, and DNMT3L [61]. Once the genes are methylated, they have been continued to methylated in the same way throughout successive cell divisions [54,55]. In this way, the methylation pattern is maintained.

It has been reported that DNA methylation is important during normal development, in biological processes such as X inactivation, genomic imprinting, and retrotransposon silencing [62]. Last 40 years, alterations in DNA methylation have been seen particularly in cancer and many diseases [63]. Additionally, CpG islands in cancer cells histone hypoacetylation and hypermethylation have been observed to be related to each other [64]. Global DNA hypomethylation (demethylation) is associated with genomic instability and activation of protooncogenes such as c-MYC, and c-H-Ras [65,66]. Hypermethylation of CpG islands, on the other hand, in the promoter regions of tumor suppressor genes has provided transcriptional silencing and genomic instability [66].

## **1.2.2 Histone Modification**

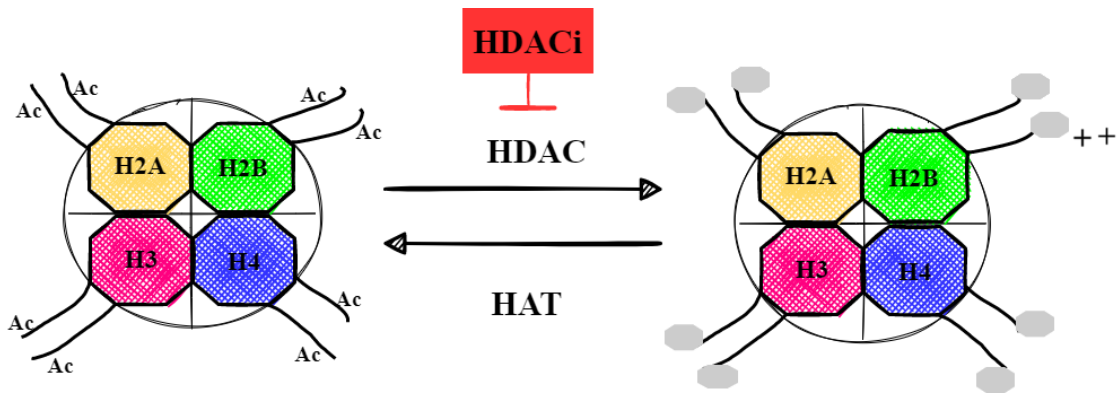
In eukaryotes, genomic DNA is packaged in the form of chromatin with histone proteins. The nucleosome is the structure that is formed by wrapping DNA onto histone structures. It consists of 147 DNA base pairs tightly wound around an octamer structure, each of the nucleosome structure consist of H3, H4, H2A, H2B histone proteins [67]. Each histone core within the nucleosome has a 25-30 residues long amino-terminal end, composed of basic amino acids, called the histone tail. They mediate histone-histone interaction and extend outward from the core structure. Also, H2A also has a 37 amino acid long carboxy-terminal region extending out of the nucleosome structure [68]. Arginine and lysine residues, which are basic aminoacids in histone proteins, are present and highly modified post-translationally [69]. Histone tails, which have a highly basic structure, are the DNA binding regions. They also have essential roles in histone-histone interactions between nucleosomes.

Chromatin allows decondensation and rearrangement in the processes of replication, transcription, and DNA repair. It is regulated by two classes of enzyme families called chromatin-regulating proteins, histone-modifying enzymes and chromatin-modeling enzymes. Post-translational modification (PTM) of histones directly affects the structure and accessibility of chromatin. Acetylation, methylation, phosphorylation, sumoylation, ubiquitylation are well-known PTMs [67]. DNA methylation and post-translational histone acetylation are the major mechanisms in the epigenetic regulation of gene expression [70]. Among these modifications, we focused on histone acetylation, which is the binding of acetyl groups ( $-\text{COCH}_3$ ) to amino acids of histone proteins.

## **1.2.3 Histone Acetylation**

In the cell acetylation and deacetylation process of amino ends of histone proteins in nucleosomes occur throughout its life. Histone acetylation and deacetylation affect many mechanisms by regulating the expression level of genes in the organism [71,72]. Histone acetylation is a dynamic process and it is regulated by histone acetyltransferase (HAT) and histone deacetyltransferase (HDAC) enzymes (Figure 1.5) [73].





**Figure 1.5 HAT (Histone Acetyltransferase) and HDAC (Histone Deacetylase) are balance of histone acetylation on gene expression. HDACi (Histone Deacetylase inhibitor) inhibits HDAC.**

Histone acetylation plays an important role in cell cycle progression and differentiation. Besides, it is a critical epigenetic modification that regulates gene expression by opening or closing the chromatin structure [74]. Histone acetylation neutralizes the positive charge of the nucleosome structure and causes the weakening of the bonds between negatively charged DNA and histone proteins. Specifically, selected lysine residues such as Lys9, Lys14 are acetylated [75,76]. Furthermore, histone acetylation is involved in the regulation of many cellular processes such as gene transcription, DNA replication, and DNA repair. Acetylation changes the chromatin structure and provides to access the target DNA of the transcription factors. It is extensively observed in transcriptionally active regions such as promoters and enhancers in the genome [77-79]. HAT are the enzymes that binds to histone protein and transfers the acetyl group from the acetyl coenzyme-A (Co-A). Until today, at least 25 HAT and 18 HDAC enzymes have been identified in humans. In the process of histone acetylation, HATs remove an acetyl group from acetyl coenzyme A and the acetyl group is bound to the amino group of histone lysine residues with covalent bonds. In this way, it causes the relaxation of the chromatin structure and the chromatin becomes transcriptionally active [80-82].

HAT enzymes have been conserved from yeasts to humans in evolutionarily. They are categorized into various groups according to their structural features, functional roles, and sequence homology. Thus, they form different histone substrate binding and catalysis mechanisms. There are two different types of HAT enzymes; Type A HAT enzymes are heterogeneous enzymes in the nucleus and are involved in the transcription of genes and

regulation of chromatin folding. There are five different Type A HAT enzymes with different goals and functions: GNAT, p300/CBP, MYST, TF, and NRCF. Type B HAT enzymes are cytoplasmic proteins responsible for the acetylation of newly synthesized histone proteins. They are classified as HAT1, HAT2, HatB3.1, Rtt109, and HAT4 [76,80,83,84].

HDAC enzymes are involved in many biological processes that takes place in our body with transcription-suppressing effects. HDAC enzymes remove acetyl groups from histone proteins. In this way, the chromatin structure becomes more condensed and causes the suppression of gene expression. HDACs are separated into four groups. Class I HDACs consist of HDAC (1, -2, -3, -8) and are located in the core. Class II HDACs migrate between the nucleus and cytoplasm, so they can deacetylate non-histone proteins found in the cytoplasm. Class II HDAC is divided into two subclasses based on sequence homology and domain organization; IIa (HDAC-4, -5, -7, -9) and IIb (HDAC-6, -10). Class III HDACs (SIRT1-7) require NAD<sup>+</sup> as a co-factor for activation. Class IV HDACs (HDAC 11) have the same homology as Class I and II HDACs. Besides histones, acetylation of non-histone proteins is also regulated by HAT and HDAC enzymes. Furthermore, these acetylations regulate gene expression levels through signal communication pathways (STAT etc.) [76,85-88].

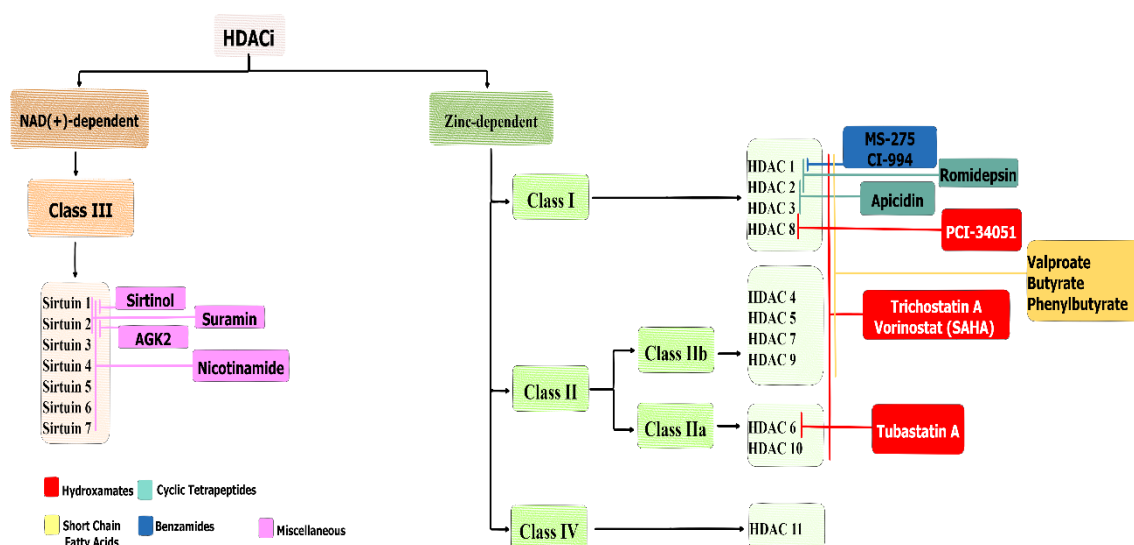
Cancer is associated with abnormality of cell functions such as DNA repair, apoptosis, autophagy and, cell motility. These cell functions are partially regulated by HDACs [70]. Because the HDAC enzymes regulate tumor suppressors and specific cell cycle genes, overexpression of HDAC enzymes lead to hypoacetylation and cause the formation of cancer [87,89]. Mutations or changes in expression of HDAC genes affect tumor development by inducing aberrant transcription of genes that regulate cell cycle, proliferation, differentiation and apoptosis [90]. HDAC enzymes suppress the expression of tumor repressor genes or regulate oncogenic cell signaling pathways [91]. In some studies, it has been proven that HDAC enzymes play an active role in many cancer types such as breast, gastrointestinal, lymphoblastic leukemia, pancreas, stomach, and lung [92-98].

The reversible nature of epigenetic modifications in cancer has revealed the epigenetic treatment option and the reversal of aberrant epigenetic changes could be targeted in epigenetic therapy. HDAC inhibitors have been shown to reverse the transformed cell phenotype and they appear to be promising therapeutic agents in cancer [99,100].

### 1.3 HDAC inhibitors

The reduced histone acetylation in the cell is has been prevented by the use of HDAC inhibitors (HDACis) [101]. HDAC inhibitors are natural or synthetic chemical compounds that reverse the activity of HDACs. They are used as promising anti-tumor agents in the treatment of various solid and hematological malignancies [102]. It has been reported that HDAC inhibitors induce cell cycle arrest, differentiation, and cell death in cancer cells, and reduce angiogenesis [103]. According to the findings of gene expression studies, it has been shown that the expression of more than 5% of genes changes after treatment with HDAC inhibitors, and these genes have been observed directly liable for the biological effects of HDAC inhibitors [104].

HDAC inhibitors are generally designed by targeting the zinc cofactor active site of HDAC enzymes. Thus, it has been aimed to reactivate the silenced genes by changing the chromatin structure [105,106]. Currently, more than 20 HDAC inhibitors are investigated at different stages of clinical trials for cancer treatment [91]. According to chemical structures HDACis, they are divided into five different groups as hydroxamates, short-chain fatty acids, benzamides, cyclic tetrapeptides, and miscellaneous (Figure 1.6) [107,108].



**Figure 1.6 Schematic representation of structural classes and target selectivity of histone deacetylase inhibitors (HDACis). NAD<sup>+</sup>, nicotinamide; Zn<sup>2+</sup>, zinc (Adepted from [111, 181]).**

Hydroxamate-based HDACis (Hb-HDACis) have been shown to have activity in hematological malignancies such as multiple myeloma and cutaneous T-cell lymphoma. Hb-HDACis have shown effects synergizes on solid tumors, such as lung, ovarian, pancreatic, breast, and prostate cancer. Currently, types of Hb-HDACis are approved for clinical use by the Food and Drug Administration (FDA) belinostat, vorinostat (SAHA), romidepsin (FK228), and panobinostat. Vorinostat (SAHA or suberoylanilide hydroxamic acid) that approved by FDA inhibited effectively class I (HDAC1, HDAC2, HDAC3, HDAC8) and class II HDACs (HDAC4, HDAC5, HDAC6, HDAC7, HDAC9, HDAC10). While Belinostat and Romidepsin are used to treat T-cell lymphoma, panobinostat is used for the treatment of myeloma [109,110, 150].

Short-chain fatty acid (SCFA) has been proved for anti-neoplastic therapeutic cell cycle arrest, apoptosis, differentiation in the tumor cells. The molecular effect pathways of butyrate have not been fully explained, however, HDAC inhibitions have been connected with of important cell cycle regulators, such as p27(KIP1), p21(CIP1/WAF1), and cyclin D. The best examples of SCFA are sodium butyrate and valproic acid [111,112].

Benzamide is a class of HDACis and they are demonstrated to be better when compared with hydroxamate HDACis. MS-275 has been used for the treatment of solid tumors and hematologic malignancies as monotherapy or in combination with other drugs. CI-994, which is a benzamide from derivative HDACi, has been observed good efficacy in the clinical study [113].

Cyclic tetrapeptide has shown a perfectly HDAC inhibitory potential and isoform selectivity. Romidepsin and Apicidin are examples that belong to this group. Romidepsin has been tested in cutaneous and peripheral T-cell lymphomas (PTCL). Besides, Romidepsin was FDA-approved has been studied in clinical trials as monotherapy as well as in combination with gemcitabine [114,115].

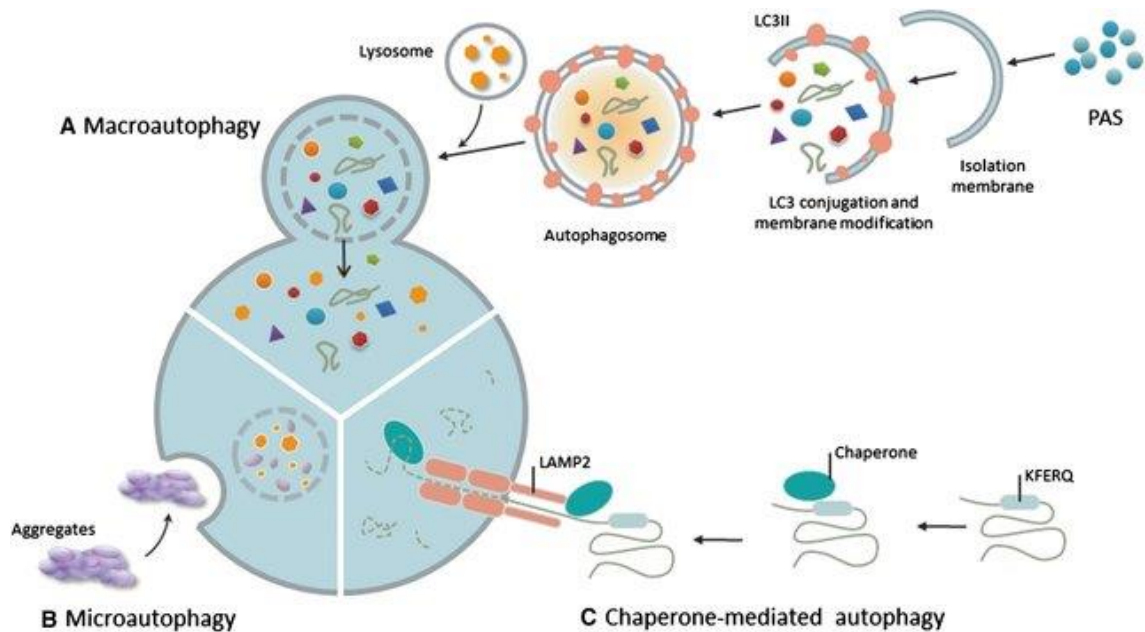
Lastly, miscellaneous HDACis are given as examples of diallyl trisulfide and tubacin. Diallyl trisulfide (DATS) has been proven to cause upregulation of the tumor suppressor p53 and of the cell cycle inhibitor p21Waf1/Cip1 in glioblastoma [116].

## **1.4 Autophagy**

Autophagy is generally controlled and balances the destruction, synthesis, and recycling of substances within the cell. In 1990, Oshumi et al. defined 30 ATGs (autophagy-related genes) in their study in yeast [117]. Autophagy means self-eating, and

when the cell is deprived of nutrients, it obtains nutrients by breaking down its structures inside the cell. In the grand scheme of things, the most evident morphological change in this type of cell death is the presence of vesicles formed in the cytoplasm surrounded by two or more layers of membranes that contain fragments of intracellular organelles such as mitochondria, endoplasmic reticulum (ER). These vesicles combine with the lysosome to be broken down by lysosomal enzymes. While proteins are degraded in the ubiquitin-proteasome system, on the contrary, intracellular organelles and some proteins are degraded by the autophagy system and reform building blocks for cell use [118,119]. Compared to cell death such as apoptosis and necrosis, the most evident feature of autophagy is its ability to break down nearly everything in the cell, including biomolecules, organelles, and microbes [120]. Accumulation of ubiquitinated proteins and deformed organelles in autophagy deficiency leads to the cellular degeneration [122]. Autophagy is also known as a defense mechanism for cell survival. In recent studies, it has been shown that complex connections have been demonstrated between autophagy, cell survival, and death [117,123,125]. In general, the studies done on autophagy; have shown that it plays a role in physiological events such as morphogenesis, regulation of metabolism, aging, cell differentiation, and the destruction of intracellular pathogens [121,123,127]. The defects in organelle clearance could damage the health of cells, thus causing cancer, neurodegeneration, and inflammation [124]. Autophagy is known that be stimulated with especially nutrient deficiency, radiation, metabolic stress, ER stress, and chemotherapeutic agents [126].

Three different mechanisms of autophagy have been identified. These are macroautophagy, microautophagy, and chaperone-mediated autophagy (Figure 1.7). The three types of autophagy mechanism, although the cell contents are destroyed by lysosomes, they have different biological properties. Macroautophagy is the most extensively studied type of autophagy and it plays an important role in the breakdown of protein fragments and damaged organelles which occurs in many cells.



**Figure 1.7 Three different mechanisms of autophagy [128].**

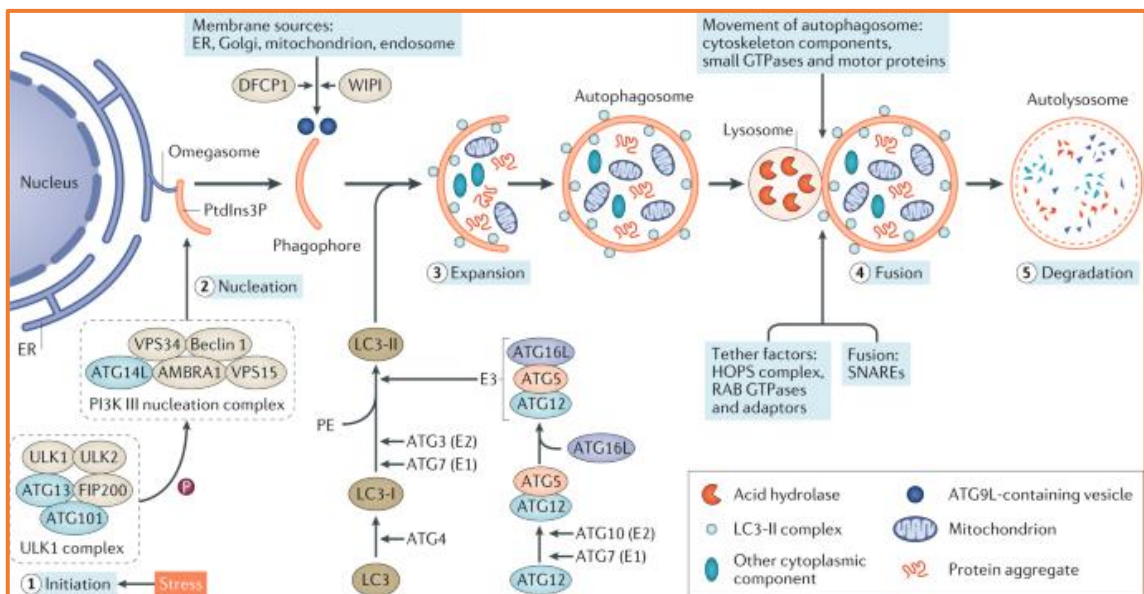
Macroautophagy is described as the formation of double-layered membrane systems (autophagosomes) that separate its contents from other cytoplasmic ingredients around target molecules. Organelles that target protein, carbohydrate, lipid, RNA, mitochondrion, and peroxisome are taken up into autophagosomes and transported to lysosomes, and degraded by lysosomal enzymes. Autophagosomes are formed by the assembly, elongation, and the closure of membranes rich in PI3P (Phosphatidyl inositol 3-phosphate) in the endoplasmic reticulum. When autophagosomes transport their contents to and combine with the lysosome, they are called autolysosomes. Its contents are broken down by acidic lysosomal hydrolases [123,128-130].

Microautophagy is the pinocytosis of the lysosome directly by cytoplasmic contents. The cytoplasmic content is taken up into the lysosome with the collapse of the lysosome membrane [123,129].

Chaperone-mediated autophagy, on the other hand, is more selective than other types of autophagy. It is the type of autophagy in which proteins containing KFERQ-like motifs are degraded. Chaperone complexes containing HSC70 recognize KFERQ motif proteins in the cytoplasm, bind to these proteins, and transport them to the lysosome membrane. It recognizes the LAMP-2 chaperone-KFERQ motif protein complex in the lysosomal membrane. The protein is degraded in the lysosome by passing through the lysosomal membrane with the help of lysosomal HSC70. In chaperone-mediated

autophagy, there are no steps such as membrane formation and confinement into the membrane [123,129,130].

Autophagy formation are thought to be centered are thought to be between the ER the Golgi junction in mammals [132]. Autophagy occurs form in stages such as initiation, nucleation (formation of the membrane), elongation (elongation of the membrane), maturation (completion and transport of the autophagosome), fusion (fusion and joining of the autophagosome and lysosome), and degradation (destruction of cargoes within the autolysosome) (Figure 1.8) [131,135].



**Figure 1.8 Autophagy occurs from stages initiation, nucleation, elongation, maturation, fusion, and degradation [135].**

In the nucleation stage; the ULK1 complex, which regulates autophagy and forms a tetrameric complex with FIP200, ATG13, ATG101, stimulates the vesicle formation by activating Class III-PI3K complex I (VPS34, VPS15, ATG14, Beclin1, AMBRA1). With the aggregation of ATG complexes in PAS (phagophore formation site), PAS localizes to the proximal region of the ER and it is named omegasome. More extension and closure of the phagophore occur via two ubiquitin-like conjugation systems (ATG5-ATG12 and LC3). LC3 (LC3A/B/C, GATE-16, and GABARAP 1/2/3, all referred to as LC3) is an ATG8 ortholog that is used as a marker for the identification of phagophore and autophagosomes. After the closure of the phagophore, autophagosomes mature with the removal of ATG proteins [131,133-135].

After autophagosomes are closed, they are transported via microtubules to the perinuclear region where lysosomes are located. The dynein protein helps to mediate the central movement of autophagosomes. Loss of dynein function causes a decrease in autophagosome-lysosome junction. Also, actin-based proteins (MYOSIN1 and MYOSIN6) play a role in autophagosome-lysosome. In general, factors that enable binding are divided into 3 classes: HOPS complex, RAB7, adapters that bind lysosome or autophagosomal components for attachment, and union mechanism. The HOPS complex is the binding factor for autophagosome-lysosome junction and consists of the proteins VPS11, VPS16, VPS18, VPS33A, VPS39, and VPS41. In the transport of autophagosomes, RAB7 connects a microtubule motor to the autophagosome by FYCO1 and facilitates kinesin-based movement towards the cell environment. The autophagosome then fuses with the late endosome or lysosome and is degraded by the cargo lysosomal enzymes it carries [136-142].

Two important signaling pathways, class III and class I phosphoinositol 3 phosphates (PI3P) play a role in autophagy control. Class III phosphoinositol 3 phosphates (PI3P) kinase initiates the formation of the autophagic vesicle. Class I negatively controls autophagy. Class I phosphatidylinositol 3-kinase (PI3K)/protein kinase B (Akt/PKB) is one of the signaling pathways that are activated with mitogenic stimuli and stimulate cell growth. Class I PI3K provides the formation of PI (3,4) P2 phosphate and PI (3,4,5) P3, and these products cause the activation of the Akt/PKB pathway. Class I phosphatidylinositol 3-kinase (PI3K)/protein kinase B/Akt pathway is known to suppress autophagy. The reason is that active Akt activates the TOR protein complex, which plays an important role in the inhibition of autophagic activity. PTEN is a tumor suppressor gene that inhibits the PI3K/Akt/mTOR signaling pathway. PTEN leads cells to autophagy by inhibition of the PI3K/Akt/mTOR signaling pathway [143-146].

Unlike normal cells, cancerous cells survive by not responding to normal cell death signals. Researchers have turned to anticancer drugs that destroy cancer cells by targeting the autophagy mechanism, which is a cell death mechanism. Anticancer drugs known as autophagy modulators work by inhibiting or activating autophagy pathways (Table 1.1).



**Table 1.1 Autophagy modulators**

Drug Name	Target
Rapamycin PP242 AZD8055 Torin 1 Sapanisertib	mTOR inhibitor [171]
Everolimus	mTORC1 inhibitor [171]
3-Methyladenine	Autophagosome formation [172]
Wortmannin	Autophagosome formation [172]
Ammonium Chloride	Autolysosomal degradation [173]
Nocodazole	Autophagosome-lysosome fusion [174]
Vinblastine	Autophagosome-lysosome fusion [174]
Hydroxychloroquine	blocking the fusion of autophagosomes with lysosomes [175]
Bafilomycin	Autophagosome-lysosome fusion [173]
Chloroquine	Autophagosomal degradation [173]

The clinical trials investigating the effectiveness of different anticancer drugs alone or in combination are ongoing on CCA patients. However, the clinical studies of autophagy modulators are not sufficient for CCA. Only chloroquine and hydroxychloroquine (HCQ) assessed in the clinical studies. Especially the combination of HCQ with ABC294640 (Opaganib) which is a sphingosine kinase 2 inhibitor (SphK) has been proven to induce of the autophagy. According to some studies, loss of activity of HDACs class I-IIa enzymes is related to the expression of autophagy regulators. Therefore, targeting autophagy can enhance the therapeutic effects of HDACis on cancer [147,148]. The effects of autophagy modulators and HDAC inhibitors in CCA are not fully known. This study targeted a novel treatment approach with the combinational therapy of autophagy and HDAC inhibitors for CCA patients.

# Chapter 2

## Materials and Methods

### 2.1 Maintenance of Cell Lines

Two different types of CCA cell lines, EGI-1 and TFK-1, were chosen to be used in experiments. These cell lines belong to patients with are dCCA [40,41]. We also used the HepG2 cell line of hepatocellular carcinoma cell lines as a control.

EGI-1, TFK-1 and HepG2 cell lines were obtained from the German National Resource Center for Biological Material (DSMZ), and they were cultured under the recommended conditions. All cell lines were cultured in RPMI medium (Euro Clone) supplemented with 10 % FBS (Biological Industries, Cat no: 04-127-1A) and 100 U/mL penicillin/streptomycin (Gibco, Cat no: 15140-122) at 37 C in 5% CO<sub>2</sub> incubator.

EGI-1, TFK-1, and HepG2 cells were seeded out as  $3 \times 10^6$ /10cm. The confluent cultures of EGI-1, TFK-1, and HepG2 were split 1:2 every 3 or 4 days. For passaging, the medium was collected and 1X PBS (Gibco) was used in order to remove the dead cell and cell debris. Afterwards, 1X trypsin (Euro Clone) (5 min for TFK-1 and HepG2, 15 min for EGI-1) was used for trypsinization. Then the cells were collected with a culture medium up to three times of trypsin in order to inactivate the trypsin enzyme and then the cells were centrifuged at 900 rpm for 5 min. The pellet dissolved with fresh media and the cells were seeded out into 10cm dishes.

### 2.2 Drug Preparation

In order to inhibit HDAC enzyme, SAHA (Sigma, SML0061), Romidepsin (Selleckchem, S3020), MS-275 (Sigma, EPS002), Tubastatin A (Sigma, SML0044), and PCI-34051 (Cayman chemical, 950762-95) were dissolved in DMSO (Panreacappllichem, 67-68-5) and their main stock solutions were prepared. While the inhibitors of the autophagy pathway Nocodazole (Sigma, M1404), Ammonium chloride (millipore, 1.01145.1000), and PP242 (Sigma, P0037) were dissolved in DMSO, Chloroquine

(chemcruz, sc-205629) and Vinblastine (Sigma, V1377) were dissolved in water and their main stock solutions were prepared.

## **2.3 Cell Viability Assay**

The cell viability of cells was calculated by MTT (3-(4,5-dimethylthiazol-2-yl)-2,5-diphenyl-2H-tetrazolium bromide) cell viability assay. All cell lines were seeded in triplicates in 96-well plates as 10.000 cells/100 uL per well. After overnight incubation, the cells were treated with DMSO, HDAC inhibitors, autophagy modulators, and combinations of HDAC inhibitors and autophagy modulators in order to check whether are proliferated in CCA. The cells were treated with DMSO, HDAC inhibitors, and autophagy modulators for 48 hours. After the incubation period, 10 µl of MTT solution (Sigma Aldrich, Cat no: M2128) was added to each well and the cells were incubated between 2 or 4 hours at 37°C in 5% CO<sub>2</sub> incubator. The cells were centrifuged at 1800 rpm 10min. The formed formazan crystals were solubilized with 100 µl of DMSO. The plates were incubated for 15 min on the shaker by being covered and the absorbance was measured with Varioskan™ LUX multimode microplate reader (Thermo Scientific™) at 570 nm. The IC<sub>30</sub> (concentration inhibiting cell growth by 70%) and IC<sub>50</sub> (concentration inhibiting cell growth by 50%) concentrations were calculated from the cell proliferation graphs by using Graphpad Prism version 8.0.2 program.

### **2.3.1 Combinations of HDACis and Autophagy Modulators**

In order to perform the combination studies of HDACis and autophagy modulators, the IC<sub>30</sub> concentrations of the SAHA, MS-275, Romidepsin, Nocodazole, PP242, Chloroquine was used.

**Table 2.1 IC<sub>30</sub> values of the HDAC inhibitors and autophagy modulators on the TFK-1 and EGI-1 cell lines.**

TFK-1		EGI-1	
HDACi	Autophagy Modulators	HDACi	Autophagy Modulators
MS-275 (3.5 nM)	Chloroquine (3.94 μM)	MS-275 (0.53 nM)	Chloroquine (5.14 μM)
	Nocodazole (2.89 μM)		Nocodazole (2.15 μM)
	PP242 (1.1 nM)		PP242 (9.02 nM)
SAHA (2.25 μM)	Chloroquine (3.94 μM)	SAHA (0.43 μM)	Chloroquine (5.14 μM)
	Nocodazole (2.89 μM)		Nocodazole (2.15 μM)
	PP242 (1.1 nM)		PP242 (9.02 nM)
Romidepsin (3.7 nM)	Chloroquine (3.94 μM)	Romidepsin (0.74 nM)	Chloroquine (5.14 μM)
	Nocodazole (2.89 μM)		Nocodazole (2.15 μM)
	PP242 (1.1 nM)		PP242 (9.02 nM)

### 2.3.2 Calculation of CI (Combination Index)

Combination analysis (isobologram analysis) was done by using the constant IC<sub>30</sub> concentrations of HDAC inhibitors with increasing concentrations of autophagy modulators. The absorbance values corresponding to each dose of the MTT assay and the percentages of cytotoxicity calculated using the formula were entered into the Calcsyn 2.0 program (CompuSyn software, Biosoft, Cambridge, United Kingdom). CI values were calculated by the program.

The effects of the drug combination used in this study were evaluated using the combination index (CI) based on Chou-Talalay's multidrug effect equation. A CI of <1, =1, or >1 is indicative of synergistic, additive, or antagonistic effects, respectively [149].

## **2.4 Analysis of Cell Cycle Distribution**

1 x10<sup>6</sup> cells/ well TFK-1 and EGI-1 cells were plated and incubated overnight. The cells were treated by single inhibitors and combination of IC<sub>30</sub> doses of the HDACis and Nocaodazole for 48h. The cells were harvested by using tyripsine and centrifuged at 260g for 10min at 4°C. The supernatant was removed and the pellet was washed with 1ml cold PBS and then centrifuged at 260g for 10min. This step was repeated twice. The cells were dissolved with 1ml cold PBS and added 4ml ethanol (70%) was added on each samples. The samples were homogenized gently via vortex. The samples were incubated at least 24h in -20 ° C for fixation of the cells.

After the fixation, the samples were centrifuged at 260g for 10min at 4°C and the supernatant was removed completely. The pellet was homogenized in 1ml cold PBS and centrifuged at 260g for 10min at 4°C. After the removal of the supernatant 1ml PBS-Triton X-100 (0.1%) (Sigma, Cat no: T8787) and 100µl RNase-A (200 µg / ml) (Sigma Aldrich, Cat no: R5503) was added onto the cells. The samples were incubated at room temperature for 30 minutes. Then, the samples were stained with 100µl PI (Propidium iodide) (1:1 in 2X PBS) and incubated at room temperature for 15 min. After the incubation, the samples were analyzed with flow cytometer (BD FACSAria™ III Cell Sorter).

## **2.5 Flow cytometric Detection of Apoptosis by Annexin-V FITC / Propidium Iodide Dual Staining**

Flow cytometry was used to determine the amount and localization of phosphatidyl serine (PS) in Romidepsin IC<sub>30</sub>, MS-275 IC<sub>30</sub>, Nocodazole IC<sub>30</sub>, Romidepsin-Nocodazole, MS-275-Nocodazole TFK-1 and EGI-1 cells by using Annexin-V FITC - Propidium Iodide (PI) (Biolegend). The CCA cells were seeded as 1x10<sup>6</sup> cells/mL on the 6-well plate and after the treatment, incubated for 48h with defined doses. Later on, the cells were collected through trypsinization. After 48 hours of incubation, the cells were centrifuged at 1700 rpm for 5 min at +4 oC and washed with cold 1X PBS twice. Then, 200 µl of 1X annexin binding solution was added (diluted with ultra-pure water, 1:10), homogenized with cells, transferred to flow glass and 2 µl of Annexin-V FITC and 4 µl of propidium iodide were added to the each obtained cell suspension. After the 15 min

incubation in the dark room, samples were analyzed by flow cytometry (BD FACSAria III Cell Analyzer).

## 2.6 Western Blot Analysis

TFK-1 and EGI-1 cells were seeded into the 6-well plates (1X10<sup>6</sup> cells/mL). Later on the overnight incubation, the cells were treated with drugs containing HDACis and Nocadazole for 48h. Following the incubation step, the cells were rinsed with cold PBS. After removal of the wash solution, the cells were lysed with RIPA lysis buffer (50Mm Tris-HCl, Ph 8.0, 150Mm Sodium Chloride, 1.0% NP-40, 0.5% Sodium deoxycholate, and 0.1% Sodium dodecyl sulfate) after addition of Pierce™ Phosphatase Inhibitor Mini Tablets and Pierce™ Protease Inhibitor Tablets, EDTA-free, and incubated with RIPA on ice for 5 min.

After collecting cells, cells were taken to an eppendorf tube and sonification at 4 times, 10sec. Later on, the samples were centrifuged at 13000g for 10 min at +4°C with a microcentrifuge. DC protein assay kit (Biorad/USA cat. no. 500-0113, cat. no. 500-0114, cat. no. 500-0115) has been used to calculate the extracted protein concentration. Varioskan™ LUX multimode microplate reader (Thermo Scientific™) has been used to measure the absorption of proteins at 750 nm. The cell lysates were loaded as 20 µg per well.

Gel electrophoresis (15% acrylamide gels) was performed. The PVDF membranes were activated using 99.8 % methanol at 5 min, and then in 1X TBS containing and 0.01 % Tween20, following the transfer, membranes were blocked with 5% dried milk (Serva, Cat. No: 42590.01) in 1X TBST, 1 hour on the shaker at room temperature and they were incubated overnight at 4°C with the primary antibodies which are GAPDH (1:2000 Proteintech), H3 (1: 1,000; Cell signaling), Ac-H3 (1: 1,000; Cell Signaling), Ac-H4 (1:1000; Cell Signaling), HDAC1 (1:1000; Santacruz) HDAC2 (1:250; Santacruz) antibodies.

Following the overnight incubation with primary antibodies that were mentioned above, membranes were washed with 1X TBST buffer for 5 min 3 times on the shaker at room temperature. Later on, the membranes were incubated with the secondary antibody for 1 hour at room temperature: Peroxidase AffiniPure Goat Anti-Rabbit IgG (1: 10,000) Peroxidase AffiniPure Goat Anti-Mouse IgG (1: 10,000). Subsequently, the washing steps with 1X TBST buffer were repeated 3 times, and ECL Western Blotting (cat. no:

K-12045-D50; Advansta) with ChemiDoc™ Imaging Systems (Biorad) was used for the signals detection.

## **2.7 Statistical Analysis**

By using GraphPad software (8.0.2, San Diego, CA) was analyze the data. All results were expressed as the mean  $\pm$  standard error (SEM) from three independent experiments. Comparisons among three groups were evaluated using two-way ANOVA by Dunnett's test.  $P < 0.05$  was considered as a statistically significant difference.



# Chapter 3

## Results

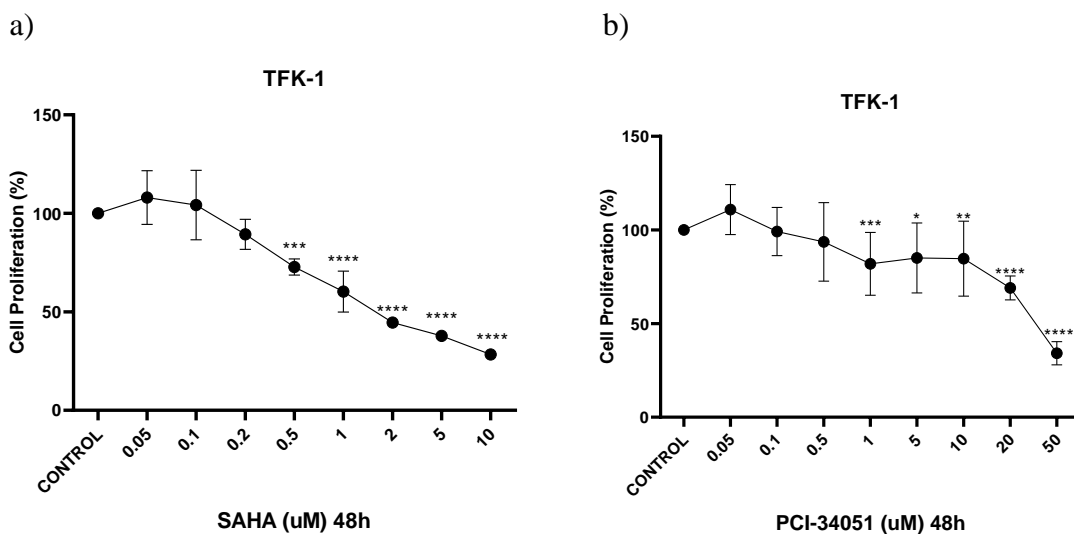
### 3.1 The effect of HDAC inhibition treatment on the proliferation of CCA and HCC cell lines

More than 20 of the HDAC inhibitors that were designed by targeting the zinc co-factor active site have been investigated in clinical trials. SAHA is the first inhibitor approved by the FDA among HDAC inhibitors and it was used as a control in our study.

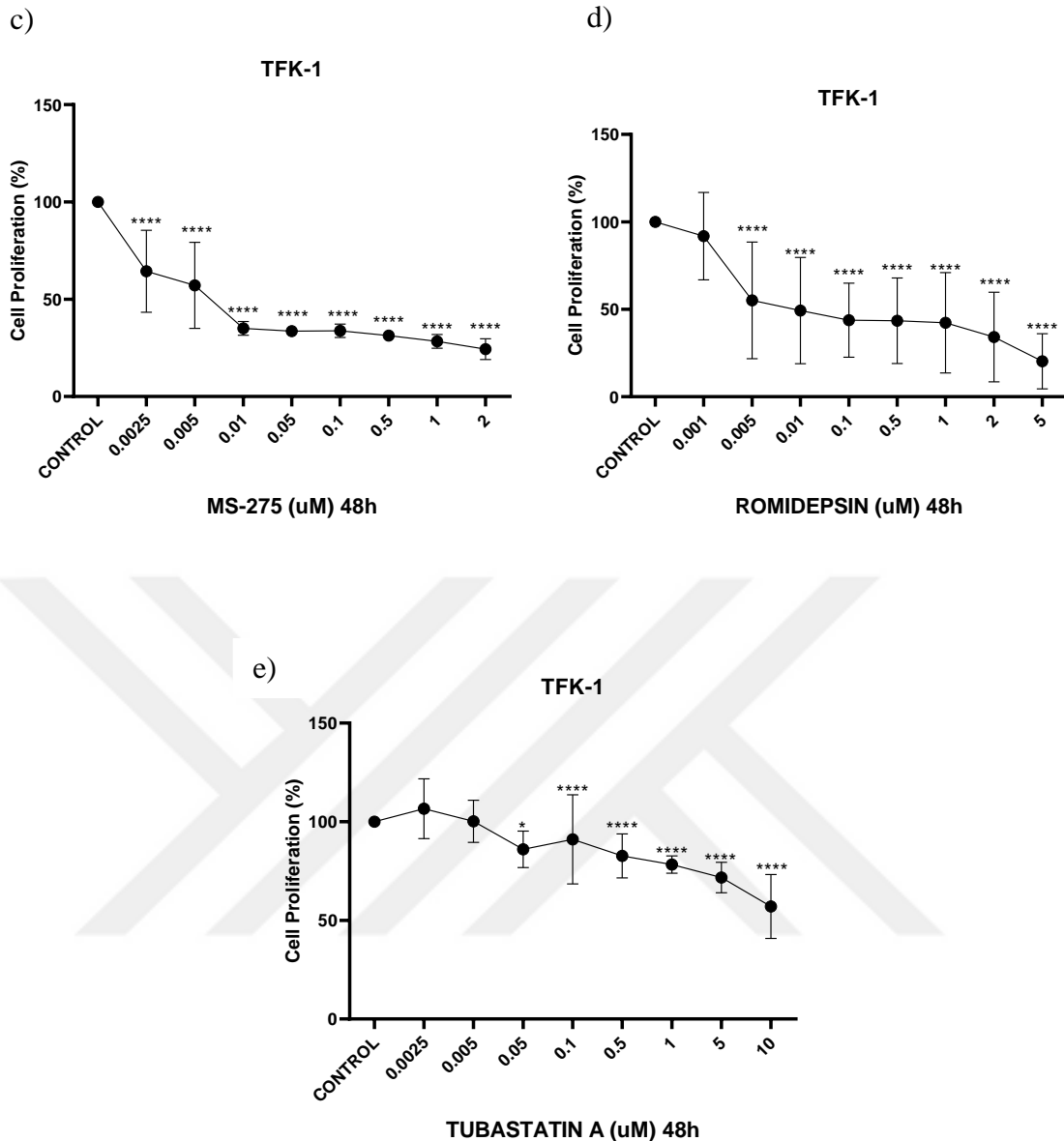
Firstly, the cytotoxic effects by treating with Romidepsin, MS-275, PCI-34051, Tubastatin A, and SAHA inhibitors were examined for CCA cell lines, TFK-1 and EGI-1, for 48 hours.

The dose optimizations of these inhibitors were made for TFK-1 and EGI-1 cell lines. Afterwards, cell proliferation graphs for TFK-1 and EGI-1 cells were prepared with 3 independent experiments, as shown in Figure 3.1 and Figure 3.2, respectively.

According to the result of this experiment, Romidepsin and MS-275 were determined to be more effective in TFK-1 and EGI-1 cell lines.



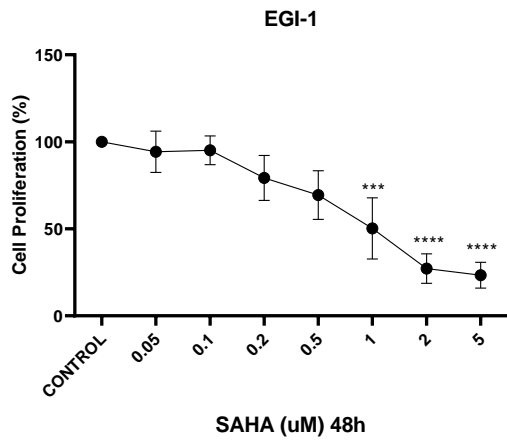




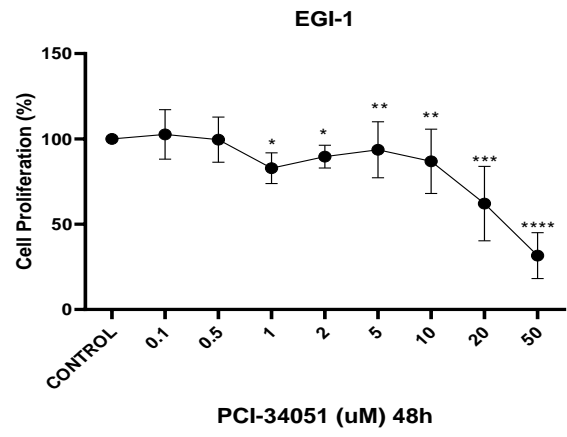
**Figure 3.1** The effect of SAHA(a), PCI-34051(b), MS-275(c), Romidepsin(d), Tubastatin A(e) treatment on the proliferation of TFK-1 cells for 48h (n=3). Each set of experiments averaged and statistical analysis was performed using two-way ANOVA by Dunnett's test. Data are presented as the mean  $\pm$  standard error. (\*=  $P \leq 0.05$ , \*\*=  $P \leq 0.01$ , \*\*\*=  $P \leq 0.001$ , \*\*\*\*=  $P \leq 0.0001$ ).

Considering the increasing doses of MS-275, the viability rate decreased more than 50% at 0.01  $\mu\text{M}$  on the TFK-1 cell. Likewise, with the increasing doses of Romidepsin, the viability rate decreased 50% at 0.005  $\mu\text{M}$  on the TFK-1 cell.

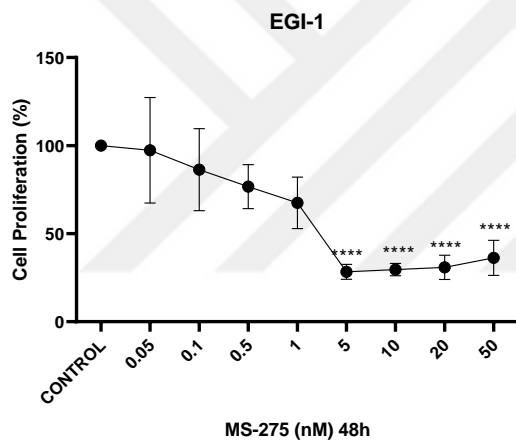
a)



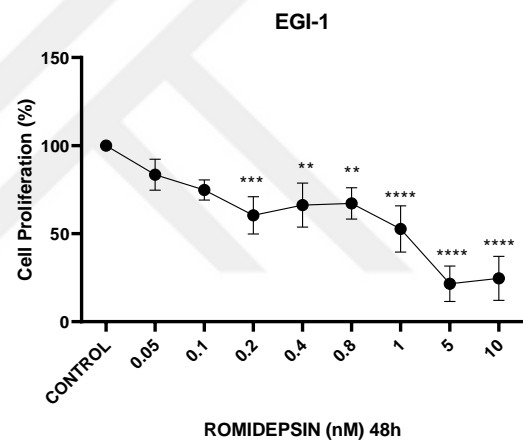
b)



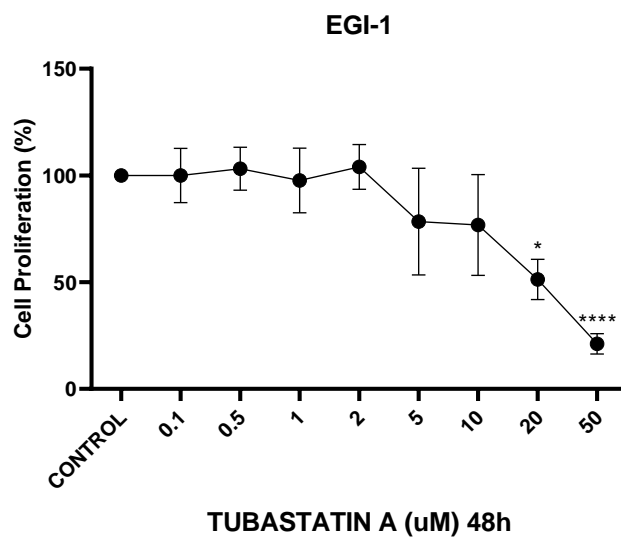
c)



d)



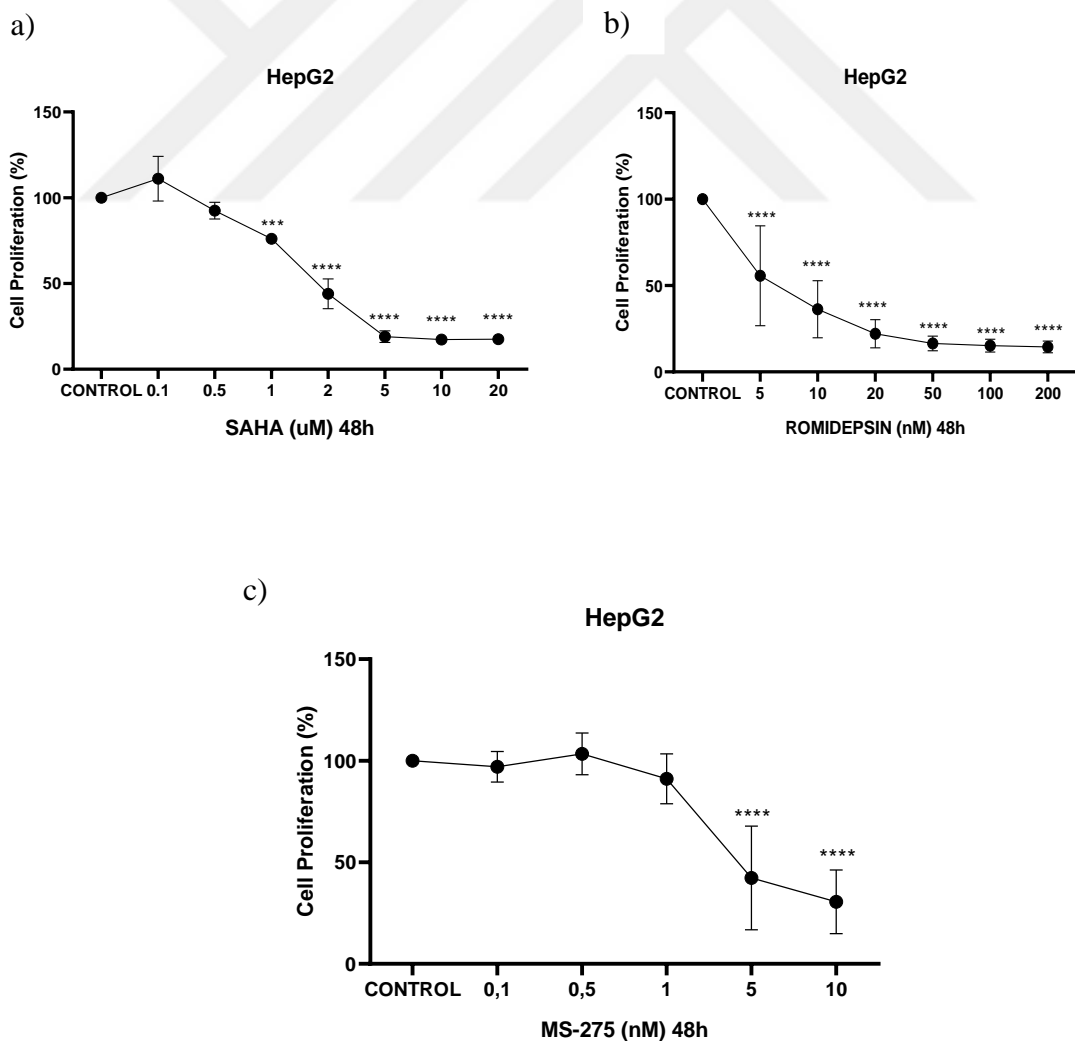
e)



**Figure 3.2** The effect of SAHA(a), PCI-34051(b), MS-275(c), Romidepsin(d), Tubastatin A(e) treatment on the proliferation of TFK-1 cells for 48h (n=3). Each set of experiments averaged and statistical analysis was performed using two-way ANOVA by Dunnett's test. Data are presented as the mean  $\pm$  standard error. (\*=  $P \leq 0.05$ , \*\*=  $P \leq 0.01$ , \*\*\*=  $P \leq 0.001$ , \*\*\*\*=  $P \leq 0.0001$ ).

The proliferation assay performed for EGI-1 cells using the HDAC inhibitors. Considering the increasing doses of MS-275, the viability rate decreased more than 50% at 5 nM on the EGI-1 cell. Likewise, with the increasing doses of Romidepsin, the viability rate decreased 50% at 1 nM on the EGI-1 cell.

The HDAC inhibitors, MS-275 and Romidepsin, were determined to be the most effective inhibitors on cell viability of TFK-1 and EGI-1 cells.



**Figure 3.3** The effect of SAHA(a), Romidepsin(b), MS-275(c), treatment on the proliferation of HepG2 cells for 48h (n=3). Each set of experiments averaged and statistical analysis was performed using two-way ANOVA by Dunnett's test. Data are presented as the mean  $\pm$  standard error. (\*=  $P \leq 0.05$ , \*\*=  $P \leq 0.01$ , \*\*\*=  $P \leq 0.001$ , \*\*\*\*=  $P \leq 0.0001$ ).

Determined HDAC inhibitors, MS-275 and Romidepsin, for TFK-1 and EGI-1, cell viability was shown in the HepG2 cell line, which is the hepatocellular carcinoma (HCC) cell line used for control (Figure 3.3).

Considering the increasing doses of MS-275, the viability rate decreased more than 50% at 5 nM on the HepG2 cell. Likewise, with the increasing doses of Romidepsin, the viability rate decreased approximately 50% at 5 nM on the HepG2 cell.

According to the results obtained on the TFK-1, EGI-1 and HepG2 cell lines, IC<sub>30</sub> (inhibition of cell viability by 30% at a particular concentration), and IC<sub>50</sub> (inhibition of cell viability by 50% at a particular concentration) values of the HDAC inhibitors chosen are calculated as follows and showed in Table 3.1.

**Table 3.1** IC<sub>30</sub> and IC<sub>50</sub> values of the HDAC inhibitors on the TFK-1, EGI-1 and HepG2 cell lines.

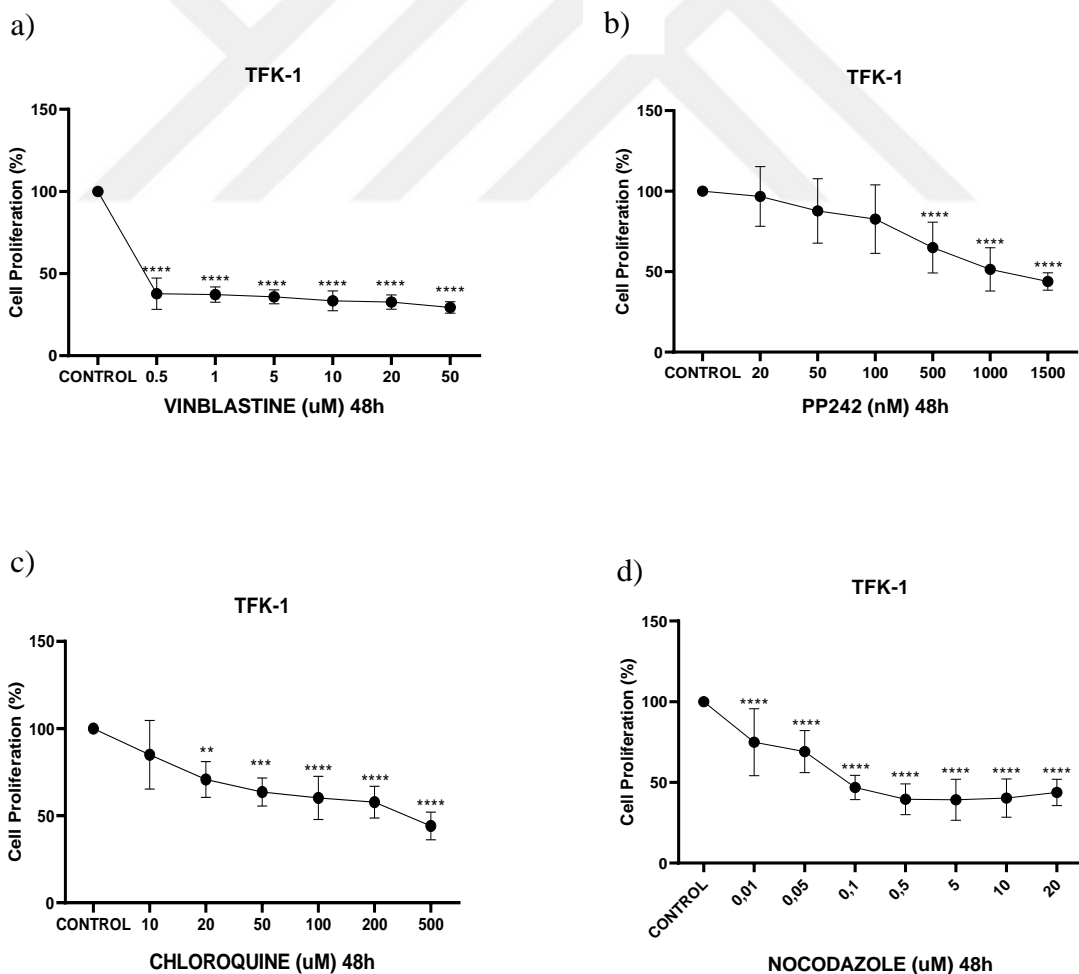
HDACis Cell lines	MS-275	Romidepsin	SAHA
<b>TFK-1</b>	3.5 nM (IC <sub>30</sub> ) 6.8 nM (IC <sub>50</sub> )	3.7 nM (IC <sub>30</sub> ) 50 nM (IC <sub>50</sub> )	2.25 $\mu$ M (IC <sub>30</sub> ) 3.96 $\mu$ M (IC <sub>50</sub> )
<b>EGI-1</b>	0.53 nM (IC <sub>30</sub> ) 2.67 nM (IC <sub>50</sub> )	0.74 nM (IC <sub>30</sub> ) 1 nM (IC <sub>50</sub> )	0.43 $\mu$ M (IC <sub>30</sub> ) 1.15 $\mu$ M (IC <sub>50</sub> )
<b>HepG2</b>	4,3 nM (IC <sub>30</sub> ) 5,72 nM (IC <sub>50</sub> )	0.94 nM (IC <sub>30</sub> ) 6.22 nM (IC <sub>50</sub> )	1.2 $\mu$ M (IC <sub>30</sub> ) 1.82 $\mu$ M (IC <sub>50</sub> )

### 3.2 The effect of autophagy modulators treatment on the proliferation of CCA and HCC cell lines

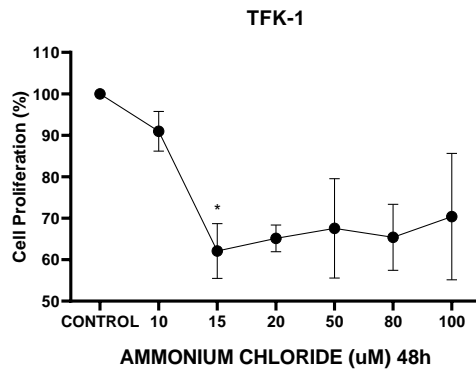
After the evaluation of HDACis, the cytotoxic effect of autophagy pathway activator PP242, autophagy pathway inhibitor vinblastine, nocodazole, chloroquine, and ammonium chloride from autophagy pathway modulators were examined on CCA cell lines for 48 hours.

The dose optimizations of autophagy modulators were done for TFK-1 and EGI-1 cell lines. Cell proliferation graphs for TFK-1 and EGI-1 cells were plotted with 3 independent experiments, as shown in Figure 3.4 and Figure 3.5, respectively.

The results of this showed nocodazole is more effective on TFK-1 and EGI-1 cell lines. Considering the increasing doses of Nocodazole, the viability rate decreased 50% at 0.1  $\mu\text{M}$  both on the TFK-1 and EGI-1 cells.

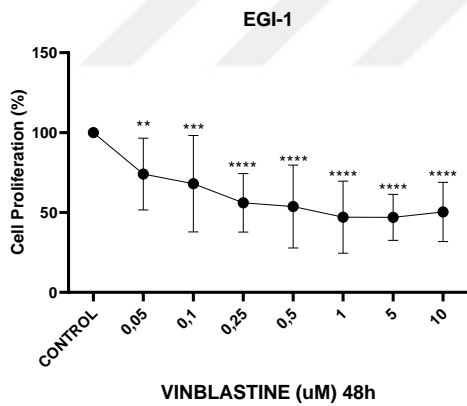


e)

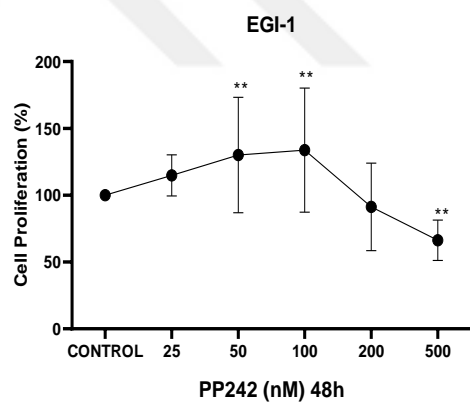


**Figure 3.4** The effect of Vinblastine (a), PP242 (b), Chloroquine (c), Nocodazole (d), Ammonium chloride (e) treatment on proliferation of TFK-1 cells for 48h (n=3). Each set of experiments averaged and statistical analysis was performed using two-way ANOVA by Dunnett's test. Data are presented as the mean  $\pm$  standard error. (\*=  $P \leq 0.05$ , \*\*=  $P \leq 0.01$ , \*\*\*=  $P \leq 0.001$ , \*\*\*\*=  $P \leq 0.0001$ ).

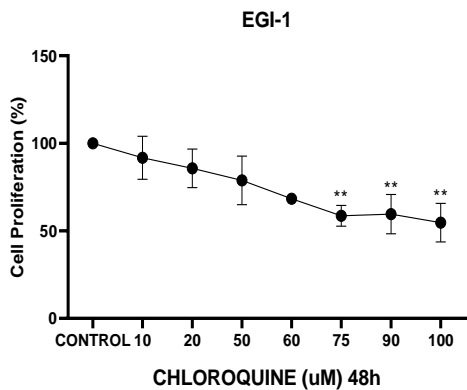
a)



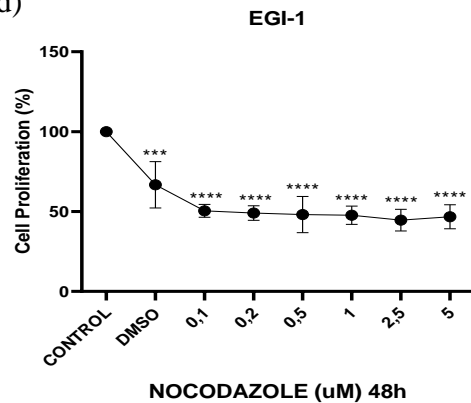
b)



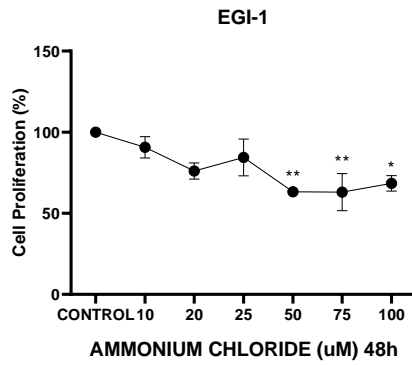
c)



d)

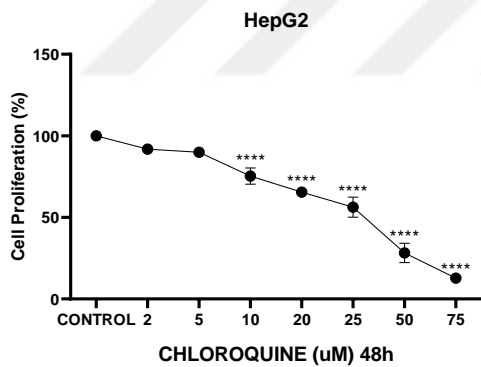


e)

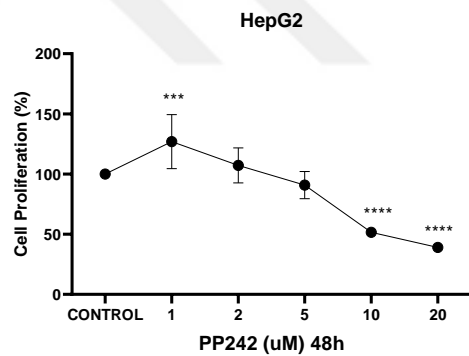


**Figure 3.5** The effect of Vinblastine (a), PP242 (b), Chloroquine (c), Nocodazole (d), Ammonium chloride (e) treatment on the proliferation of EGI-1 cells for 48h (n=3). Each set of experiments averaged and statistical analysis was performed using two-way ANOVA by Dunnett's test. Data are presented as the mean  $\pm$  standard error. (\*=  $P \leq 0.05$ , \*\*=  $P \leq 0.01$ , \*\*\*=  $P \leq 0.001$ , \*\*\*\*=  $P \leq 0.0001$ ).

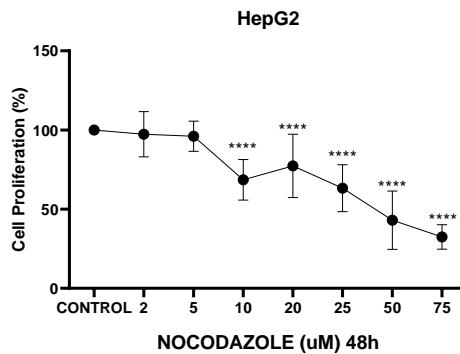
a)



b)



c)



**Figure 3.6** The effect of Chloroquine(a), PP242 (b), Nocodazole (c), treatment on the proliferation of HepG2 cells for 48h (n=3). Each set of experiments averaged and statistical analysis was performed using two-way ANOVA by Dunnett's test. Data are presented as the mean  $\pm$  standard error. (\*=  $P \leq 0.05$ , \*\*=  $P \leq 0.01$ , \*\*\*=  $P \leq 0.001$ , \*\*\*\*=  $P \leq 0.0001$ ).

The most effective autophagy inhibitors were selected as Chloroquine, Nocodazole, and PP242 (Figure 3.6). Considering the increasing doses of Nocodazole, the viability rate decreased 50% at 50  $\mu$ M on the HepG2 cell. On the TFK-1, EGI-1 and HepG2 cell lines, IC<sub>30</sub>, and IC<sub>50</sub> values of the autophagy modulators chosen are shown in Table 3.2.

**Table 3.2** IC<sub>30</sub>, and IC<sub>50</sub> values of the autophagy modulators on the TFK-1, EGI-1 and HepG2 cell lines.

Drugs Cell lines	Chloroquine	Nocodazole	PP242
<b>TFK-1</b>	3.94 $\mu$ M (IC <sub>30</sub> ) 6.35 $\mu$ M (IC <sub>50</sub> )	2.89 $\mu$ M (IC <sub>30</sub> ) 5.2 $\mu$ M (IC <sub>50</sub> )	1.1 nM (IC <sub>30</sub> ) 2.9 nM (IC <sub>50</sub> )
<b>EGI-1</b>	5.14 $\mu$ M (IC <sub>30</sub> ) 8.18 $\mu$ M (IC <sub>50</sub> )	2.15 $\mu$ M (IC <sub>30</sub> ) 5.7 $\mu$ M (IC <sub>50</sub> )	9.02 nM (IC <sub>30</sub> ) 12.04 nM (IC <sub>50</sub> )
<b>HepG2</b>	4.1 $\mu$ M (IC <sub>30</sub> ) 5.71 $\mu$ M (IC <sub>50</sub> )	4.7 $\mu$ M (IC <sub>30</sub> ) 6.7 $\mu$ M (IC <sub>50</sub> )	4.4 $\mu$ M (IC <sub>30</sub> ) 5.71 $\mu$ M (IC <sub>50</sub> )

According to the results obtained from HDAC inhibitors and autophagy modulators, the MS-275 and Romidepsin from HDAC inhibitors and Chloroquine, Nocodazole, PP242 from autophagy modulators demonstrated the more effective on cell proliferation of the TFK-1 and EGI-1.

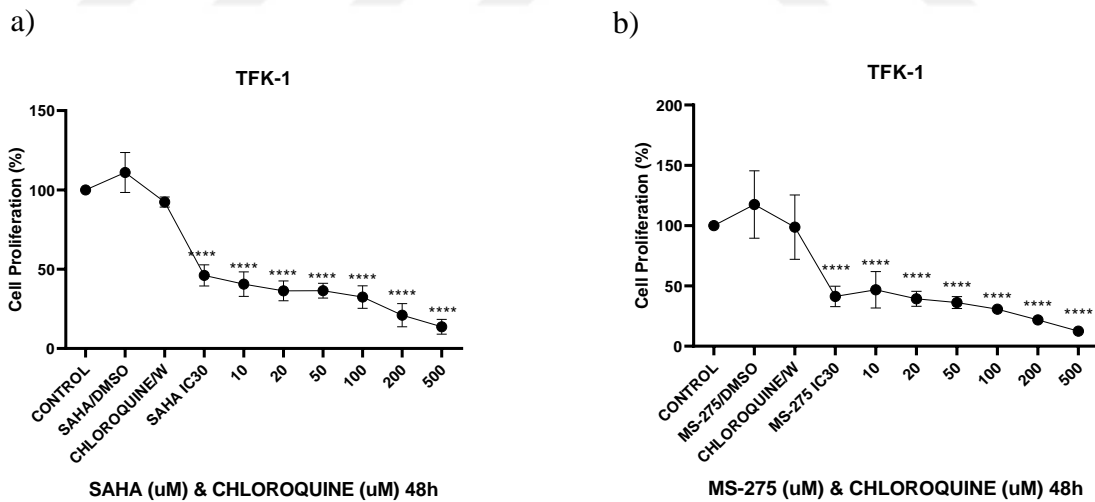


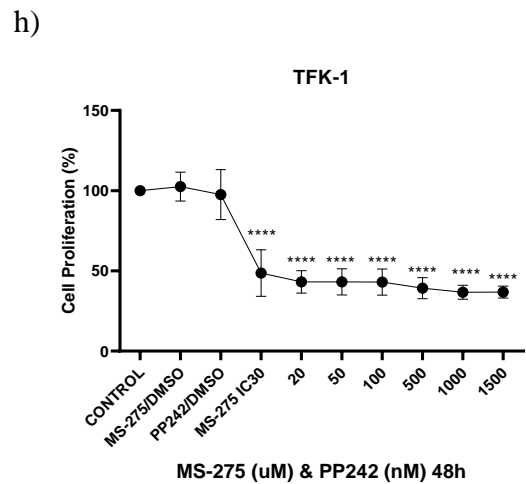
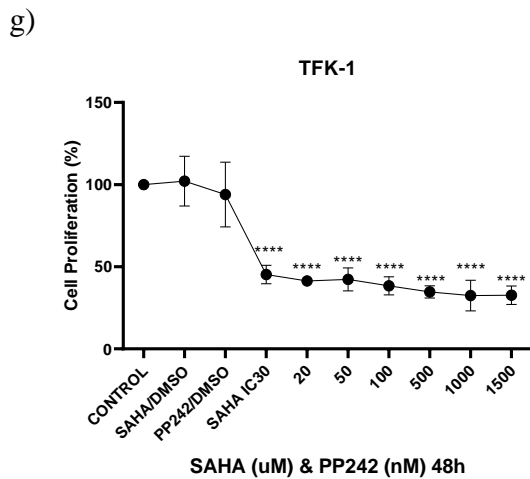
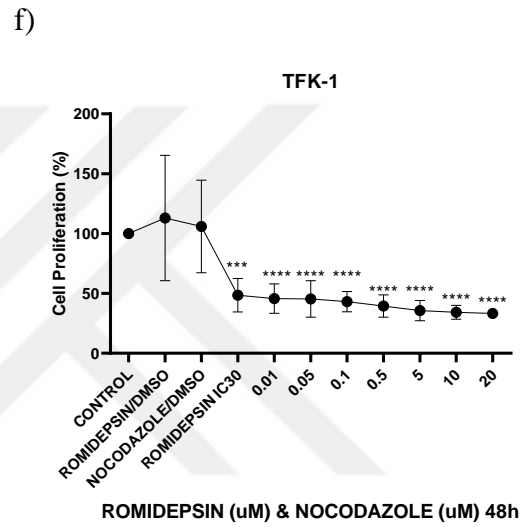
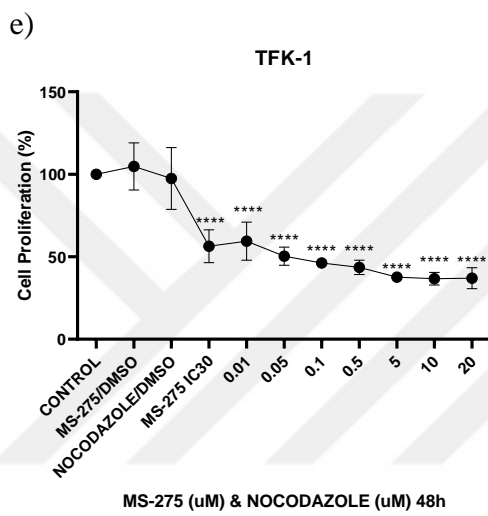
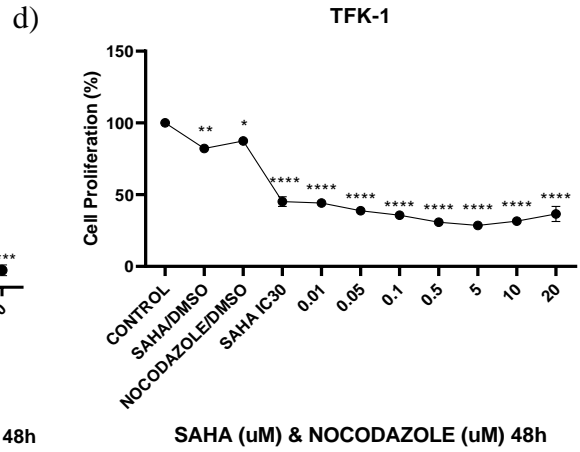
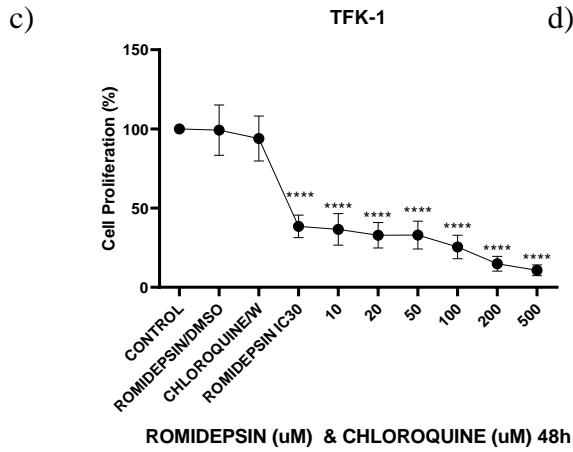
### 3.3 The effect of combination treatment of HDAC inhibitors and autophagy modulators on the proliferation of cholangiocarcinoma cell lines

After determining the IC values of HDAC inhibitors and autophagy pathway modulators, the combination experiments were continued with the HDAC inhibitors, MS-275, Romidepsin, SAHA, and the autophagy pathway modulation. Chloroquine, Nocodazole, and PP242, on the TFK-1, EGI-1, and HepG2 cell lines.

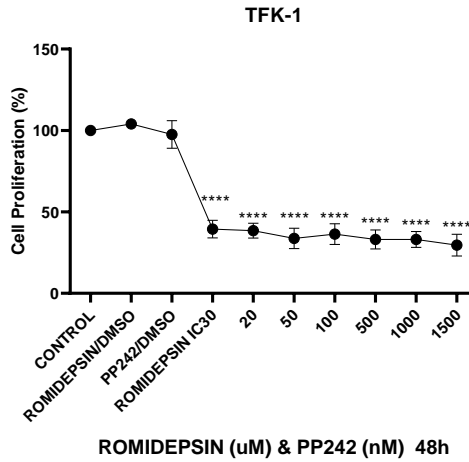
For the combination treatment, the IC<sub>30</sub> values of SAHA (2.25  $\mu$ M), MS-275 (0.0035  $\mu$ M), and Romidepsin (0.0037  $\mu$ M), and increasing doses of the autophagy modulators chosen were applied on the TFK-1, EGI-1 and HepG2 cells for 48 hours.

Significant inhibition on cell viability was observed compared to the control group when the cells treated with the IC<sub>30</sub> value of HDAC inhibitors and increasing doses of the Chloroquine, Nocodazole, and PP242 on the TFK-1 (Figure 3.7), EGI-1 (Figure 3.8), and HepG2 (Figure 3.9) cells for 48 hours.

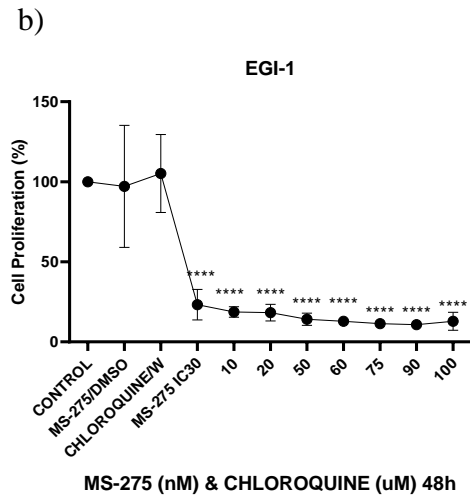
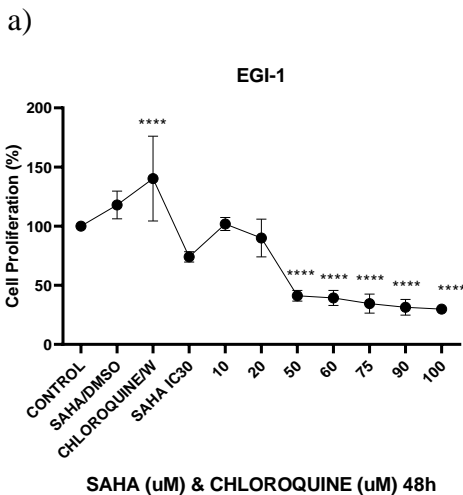


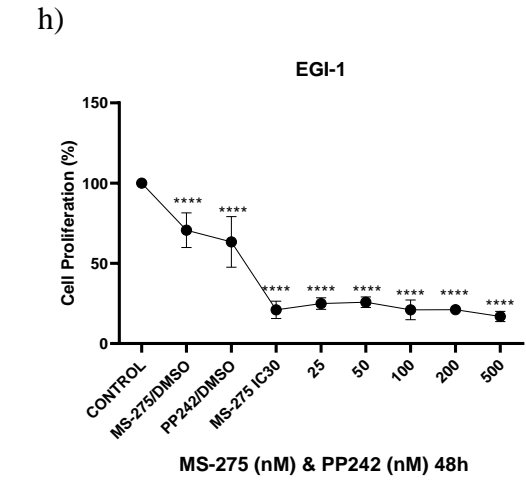
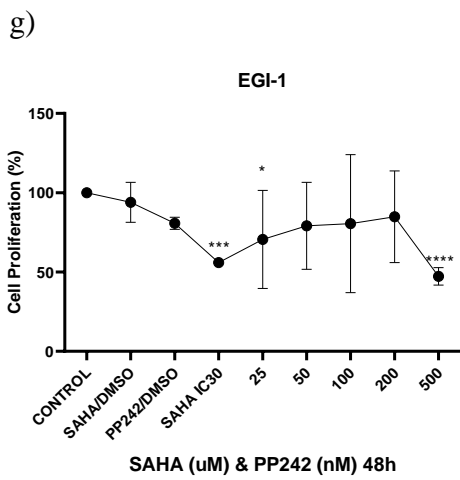
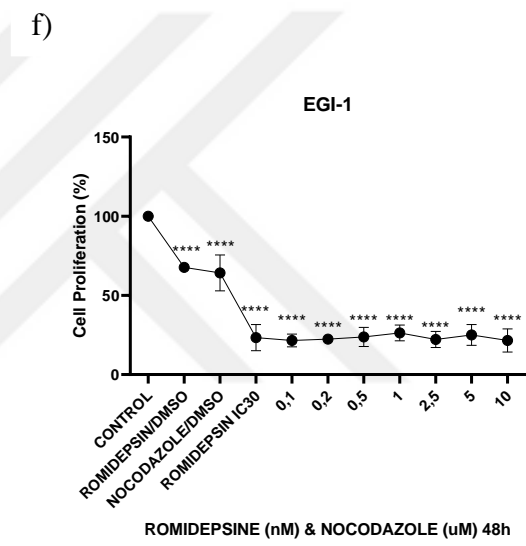
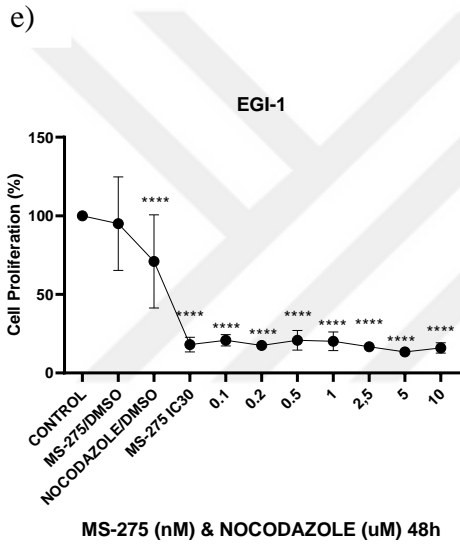
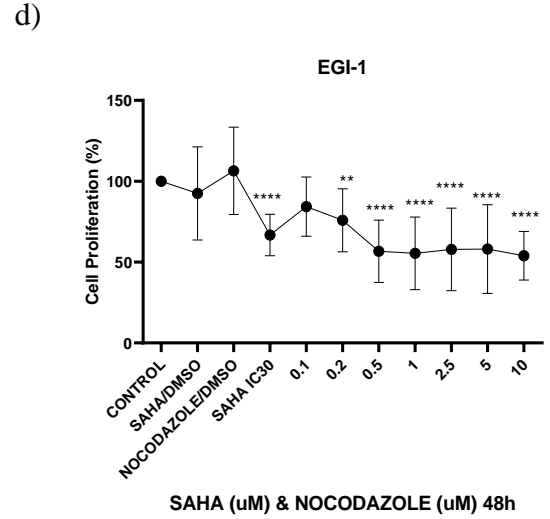
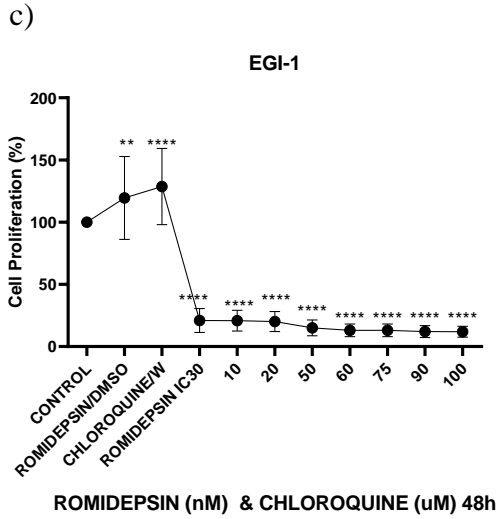


i)

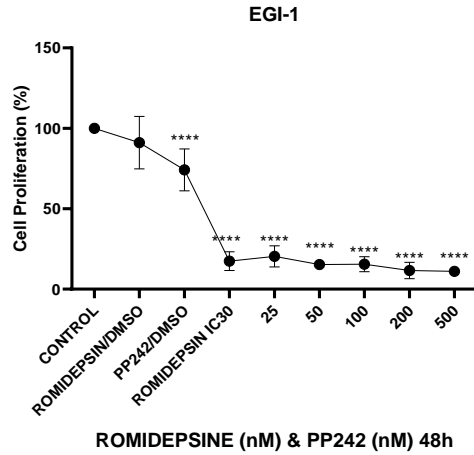


**Figure 3.7** The combination treatment of constant IC<sub>30</sub> values of HDAC inhibitors with increasing doses of autophagy modulators were applied on the TFK-1 cell for 48h (n=3). The combinations of Chloroquine doses and a) SAHA IC<sub>30</sub> (2.25 μM), b) MS-275 IC<sub>30</sub> (3.5 nM) c) Romidepsin IC<sub>30</sub> (3.7 nM), respectively. The combinations of Nocodazole and d) SAHA IC<sub>30</sub> (2.25 μM), e) MS-275 IC<sub>30</sub> (3.5 nM) f) Romidepsin IC<sub>30</sub> (3.7 nM), respectively. The combinations of the PP242 and g) SAHA IC<sub>30</sub> (2.25 μM), h) MS-275 IC<sub>30</sub> (3.5 nM) i) Romidepsin IC<sub>30</sub> (3.7 nM), respectively. Each set of experiments averaged and statistical analysis was performed using two-way ANOVA by Dunnett's test. Data are presented as the mean ± standard error. W: Water (\*= P ≤ 0.05, \*\*= P ≤ 0.01, \*\*\*= P ≤ 0.001, \*\*\*\*= P ≤ 0.0001).

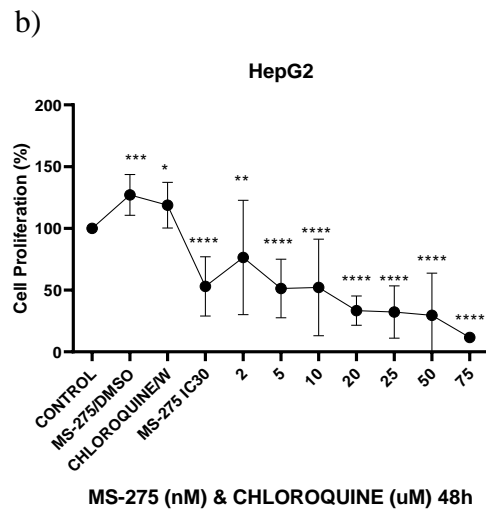
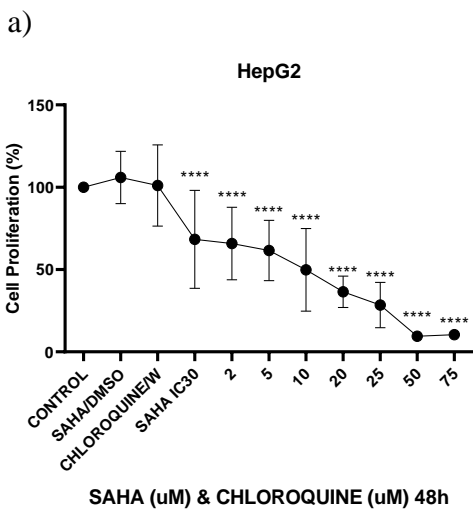


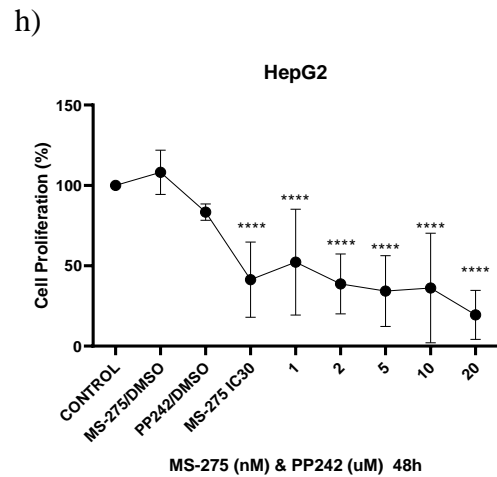
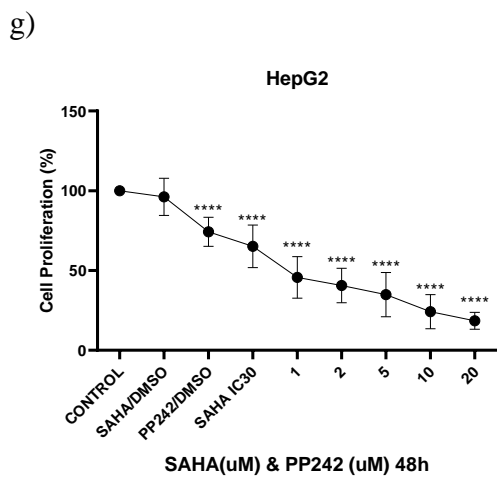
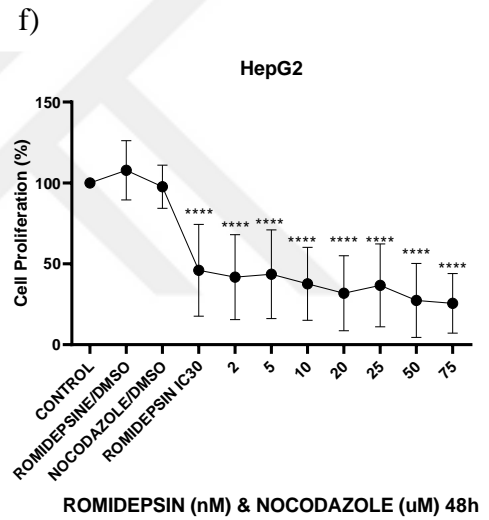
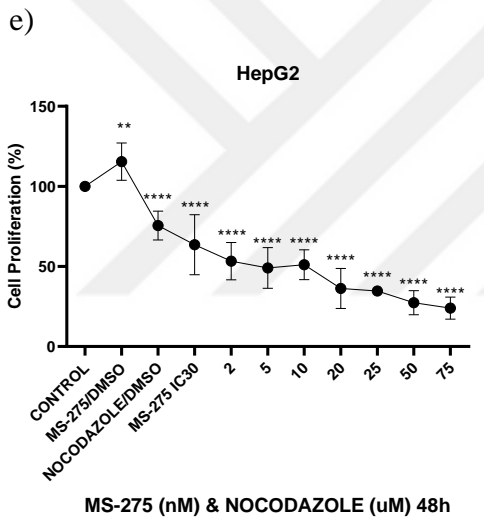
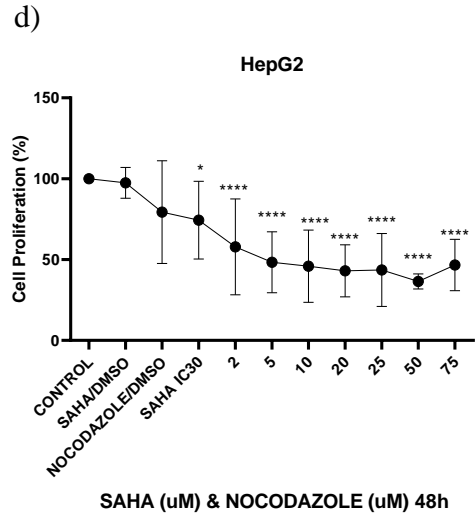
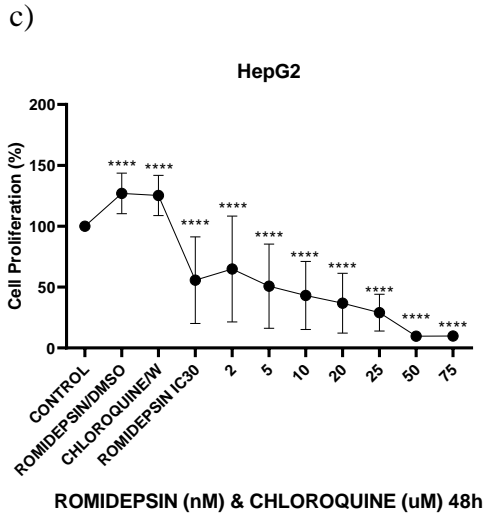


i)

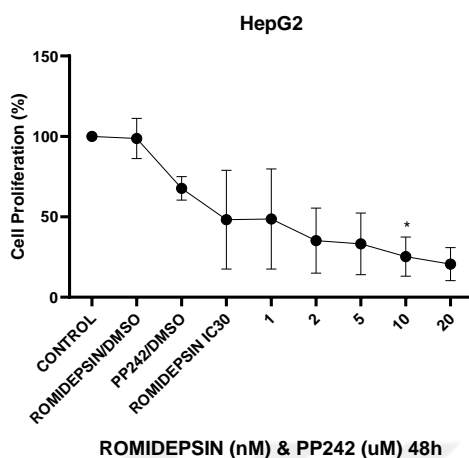


**Figure 3.8** The combination treatment of constant IC<sub>30</sub> values of HDAC inhibitors and increasing doses of autophagy modulators were applied on the EGI-1 cell for 48h (n=3). The combinations of Chloroquine doses and a) SAHA IC<sub>30</sub> (0.43 μM), b) MS-275 IC<sub>30</sub> (0.53 nM) c) Romidepsin IC<sub>30</sub> (0.74 nM), respectively. The combinations of Nocodazole and d) SAHA IC<sub>30</sub> (0.43 μM), e) MS-275 IC<sub>30</sub> (0.53 nM) f) Romidepsin IC<sub>30</sub> (0.74 nM), respectively. The combinations of PP242 and g) SAHA IC<sub>30</sub> (0.43 μM), h) MS-275 IC<sub>30</sub> (0.53 nM), i) Romidepsin IC<sub>30</sub> (0.74 nM), respectively. Each set of experiments averaged and statistical analysis was performed using two-way ANOVA by Dunnett's test. Data are presented as the mean ± standard error. W: Water (\*= P ≤ 0.05, \*\*= P ≤ 0.01, \*\*\*= P ≤ 0.001, \*\*\*\*= P ≤ 0.0001).





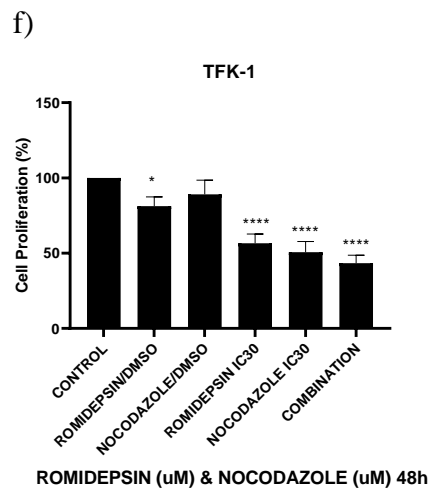
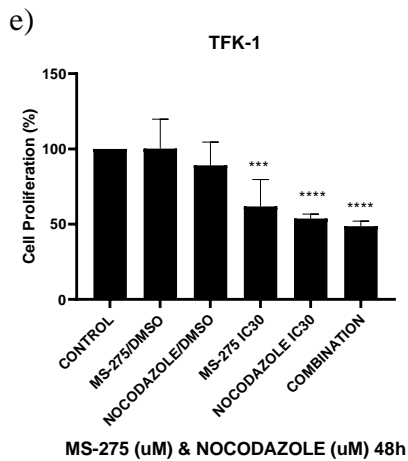
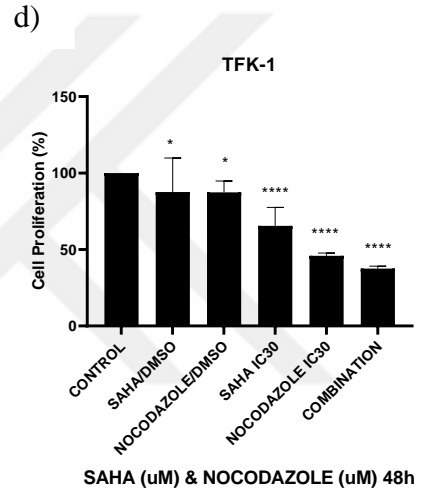
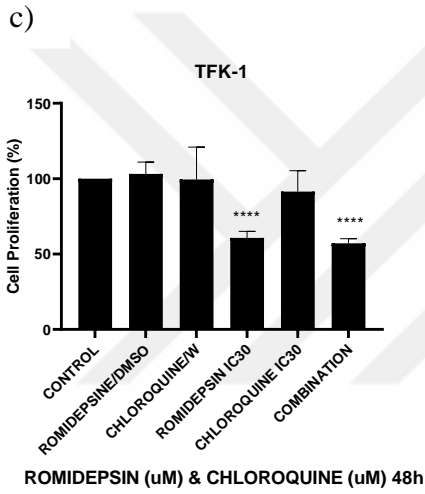
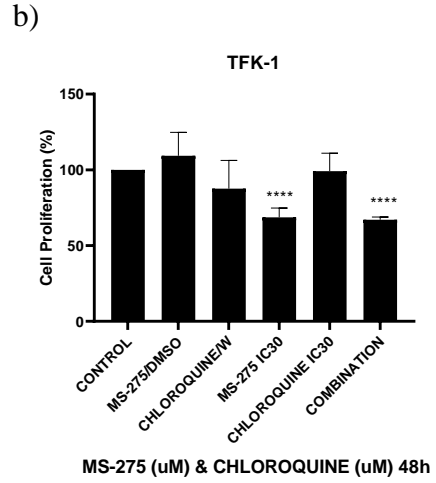
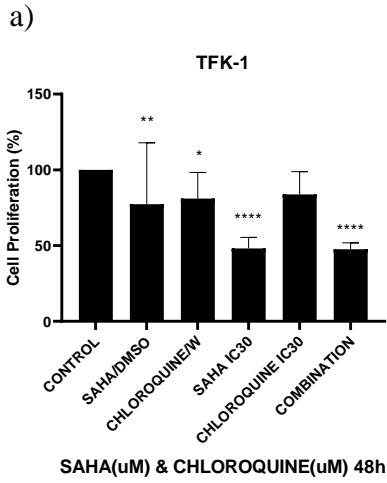
i)



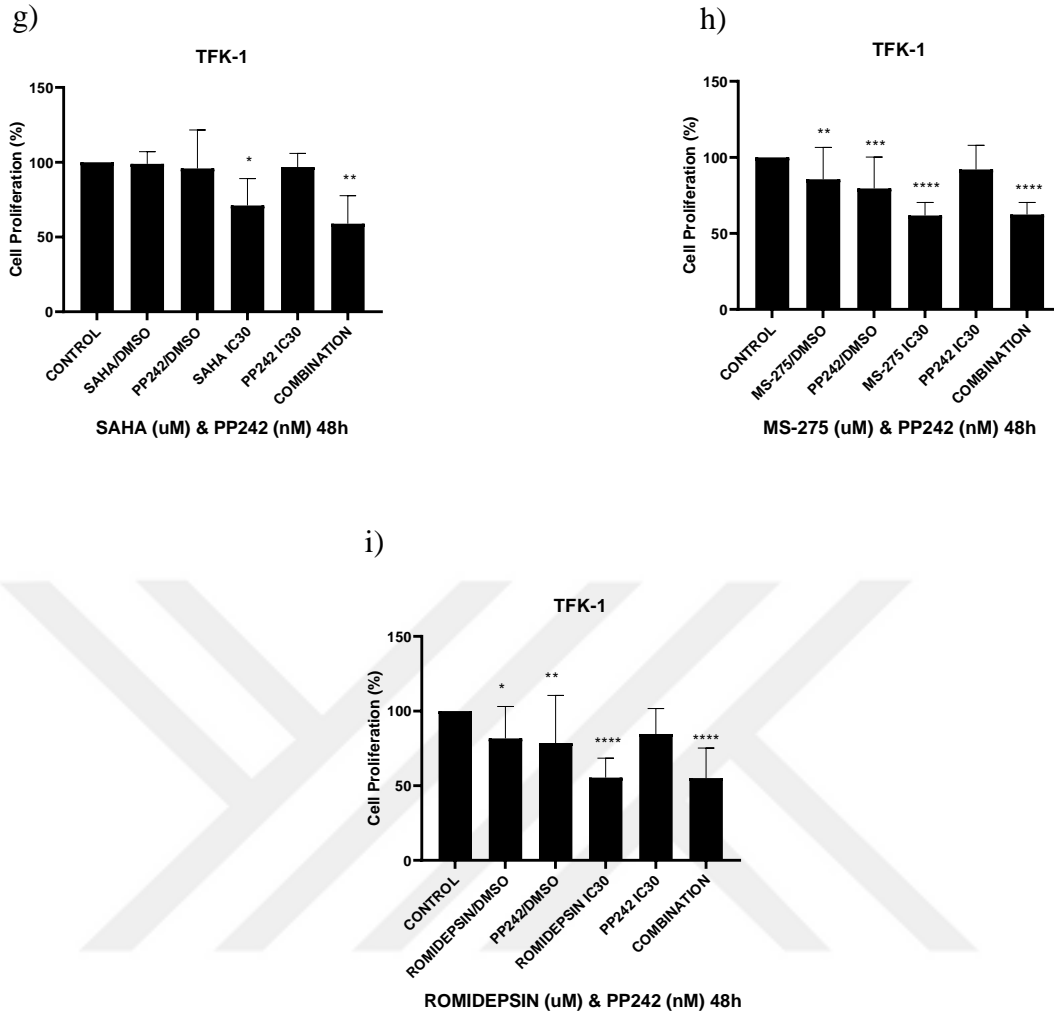
**Figure 3.9** The combination treatment of constant IC<sub>30</sub> values of HDAC inhibitors and increasing doses of autophagy modulators were applied on the HepG2 cell for 48h (n=3). The combinations of Chloroquine doses and a) SAHA IC<sub>30</sub> (1.2 μM), b) MS-275 IC<sub>30</sub> (4.3 nM) c) Romidepsin IC<sub>30</sub> (0.94 nM), respectively. The combinations of Nocodazole doses and d) SAHA IC<sub>30</sub> (1.2 μM), e) MS-275 IC<sub>30</sub> (4.3 nM) f) Romidepsin IC<sub>30</sub> (0.94 nM), respectively. The combinations of PP242 doses and g) SAHA IC<sub>30</sub> (1.2 μM), h) MS-275 IC<sub>30</sub> (4.3 nM), i) Romidepsin IC<sub>30</sub> (0.94 nM), respectively. W: water. Each set of experiments averaged and statistical analysis was performed using two-way ANOVA by Dunnett's test. Data are presented as the mean ± standard error. (\*= P ≤ 0.05, \*\*= P ≤ 0.01, \*\*\*= P ≤ 0.001, \*\*\*\*= P ≤ 0.0001).

### **3.4 The combination treatment of the IC<sub>30</sub> values HDAC inhibitors and autophagy modulators and its effect on the proliferation of cholangiocarcinoma cell lines**

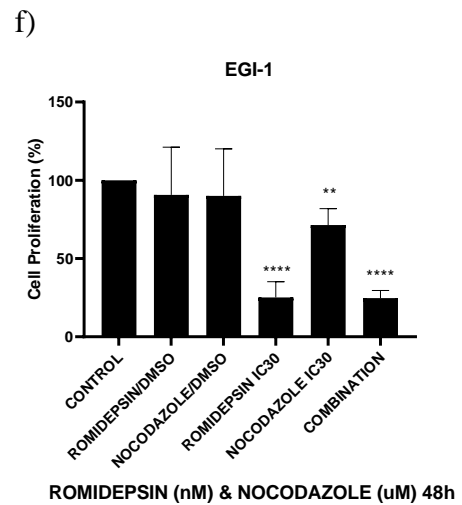
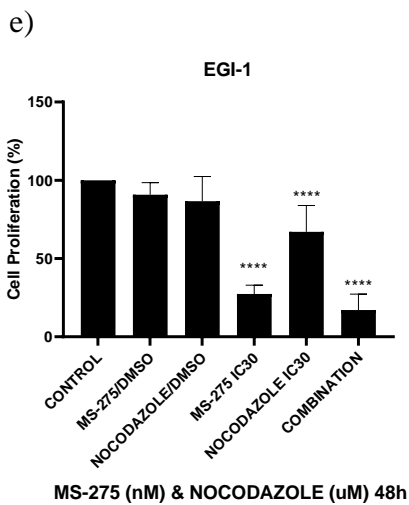
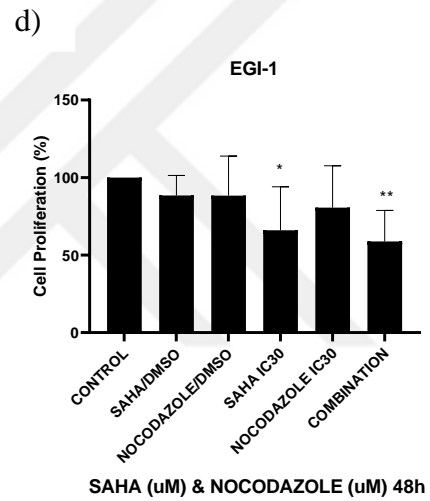
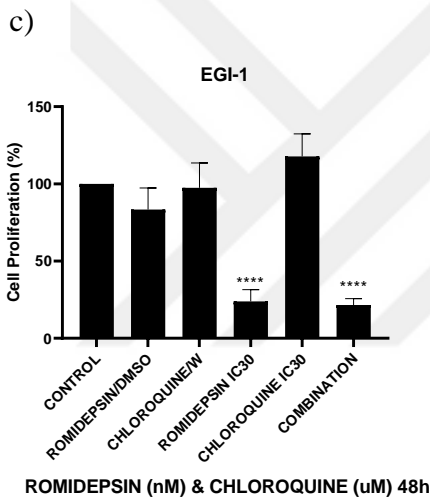
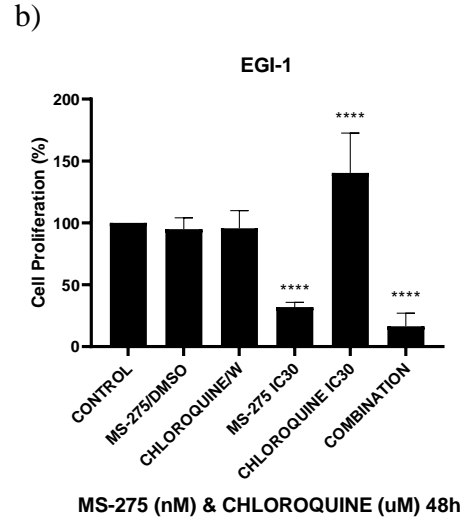
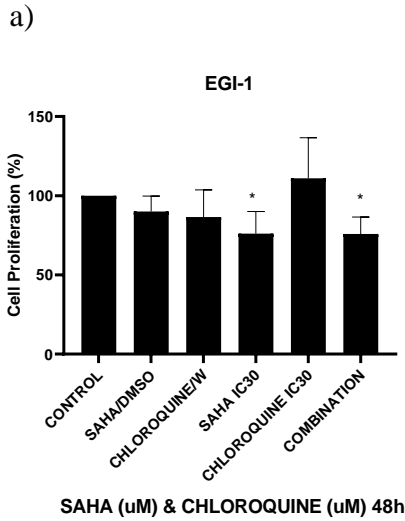
As another approach, the IC<sub>30</sub> values of the HDAC inhibitors and autophagy modulators were applied on the TFK-1, EGI-1, and HepG2 cells (Figure 3.10, Figure 3.11, and Figure 3.12).

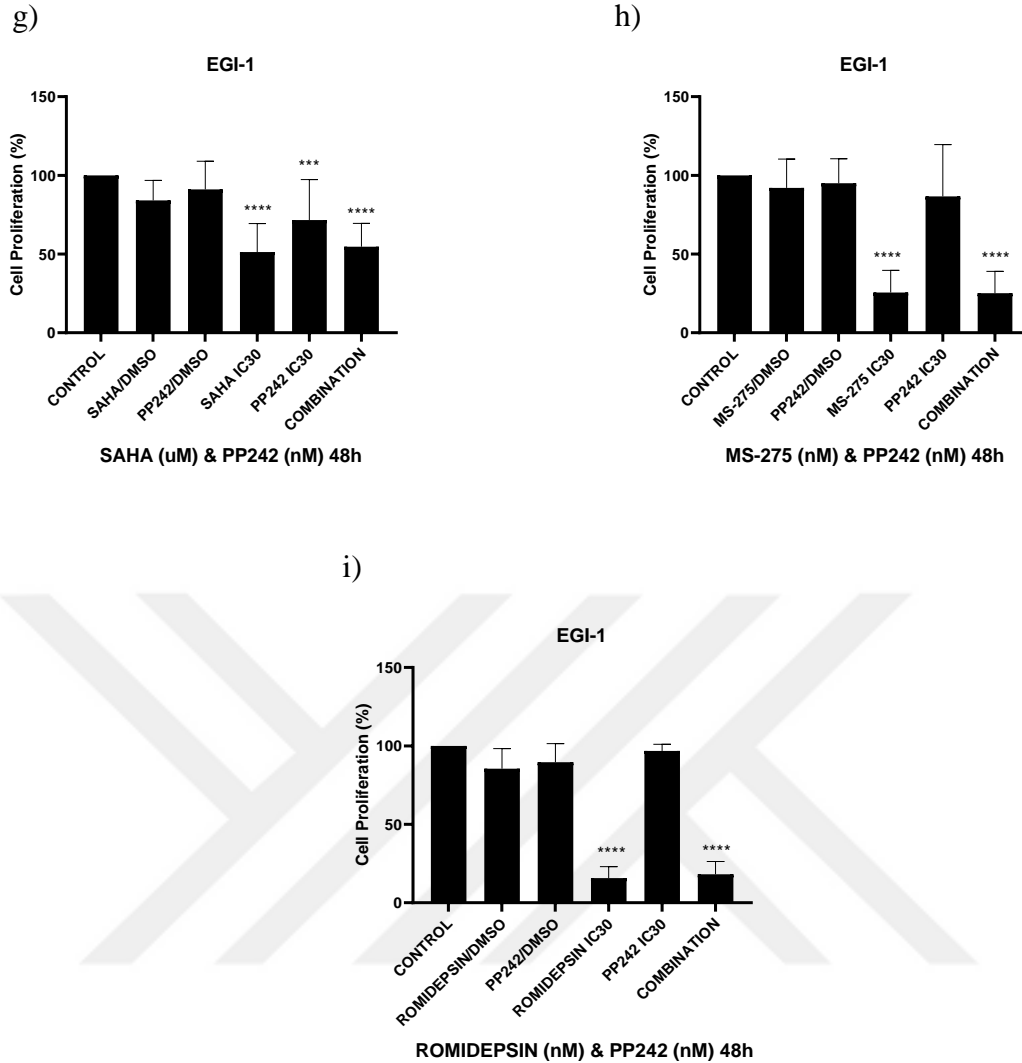




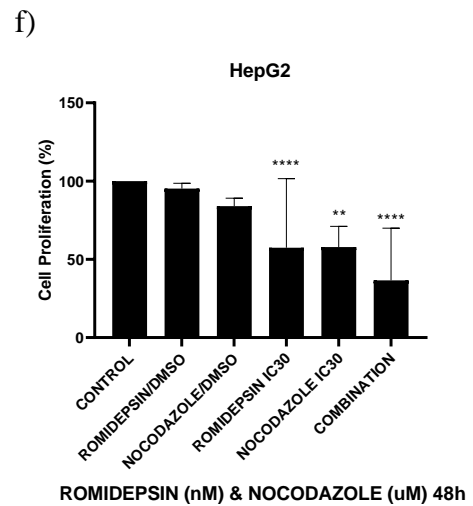
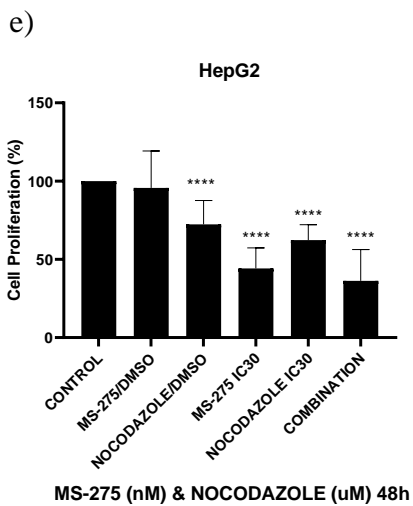
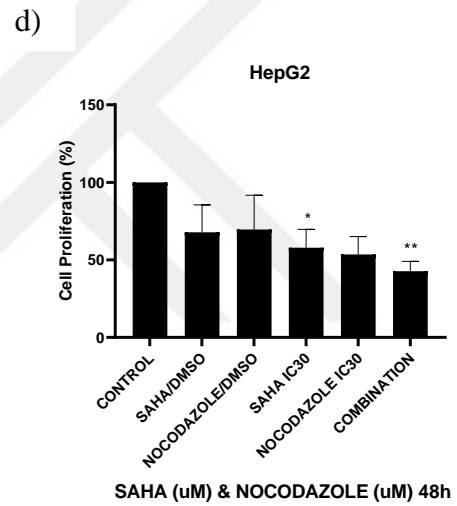
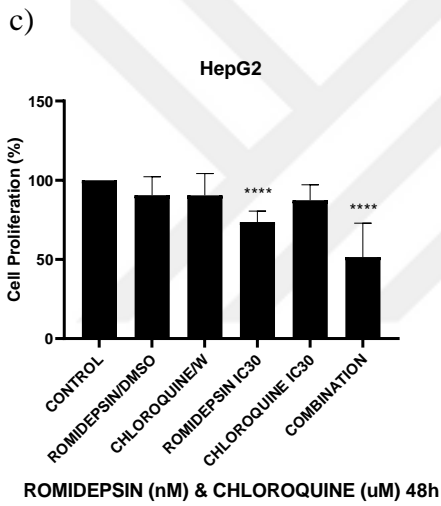
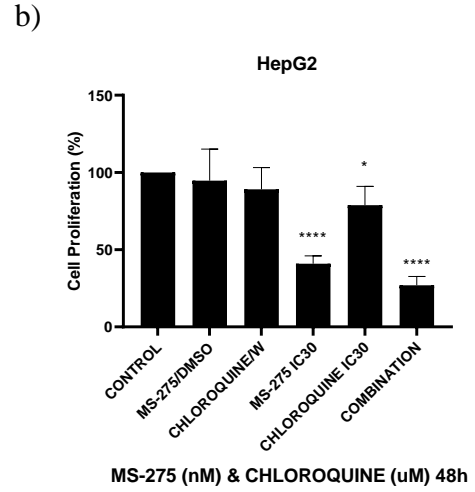
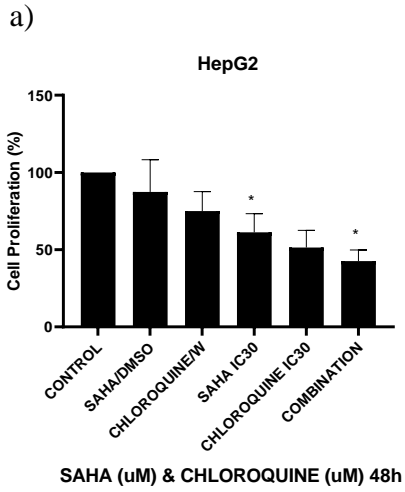


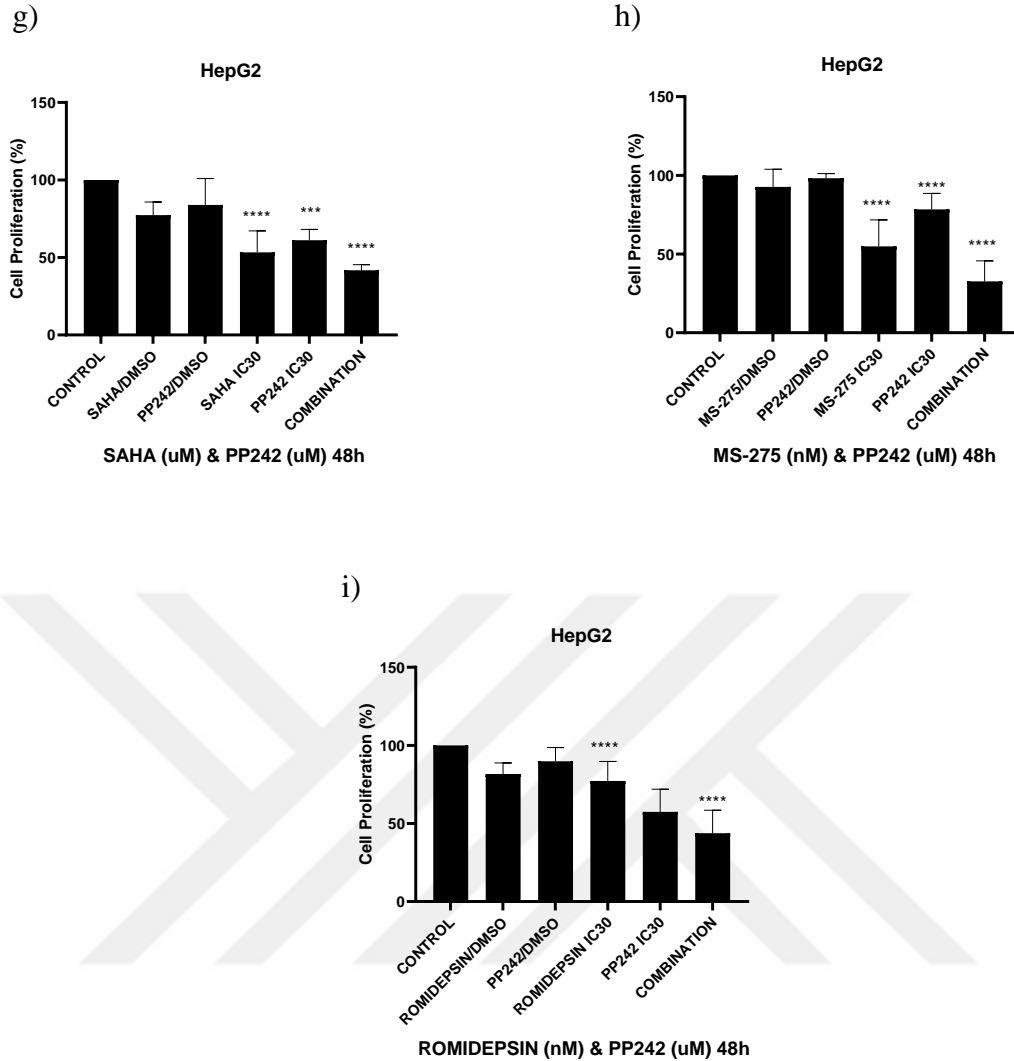
**Figure 3.10** The combination treatment of IC<sub>30</sub> values of HDAC inhibitors and of autophagy modulators for TFK-1 cell for 48h (n=3). The combinations of the Chloroquine IC<sub>30</sub> (3.94 μM) and a) SAHA IC<sub>30</sub> (2.25 μM), b) MS-275 IC<sub>30</sub> (3.5 nM) c) Romidepsin IC<sub>30</sub> (3.7 nM), respectively. The combinations of the Nocodazole IC<sub>30</sub> (2.89 μM) and d) SAHA IC<sub>30</sub> (2.25 μM), e) MS-275 IC<sub>30</sub> (3.5 nM) f) Romidepsin IC<sub>30</sub> (3.7 nM), respectively. The combinations of the PP242 IC<sub>30</sub> (1.1 nM) and g) SAHA IC<sub>30</sub> (2.25 μM), h) MS-275 IC<sub>30</sub> (3.5 nM) i) Romidepsin IC<sub>30</sub> (3.7 nM), respectively. Each set of experiments averaged and statistical analysis was performed using two-way ANOVA by Dunnett's test. Data are presented as the mean ± standard error. W: Water (\*= P ≤ 0.05, \*\*= P ≤ 0.01, \*\*\*= P ≤ 0.001, \*\*\*\*= P ≤ 0.0001).





**Figure 3.11** The combination treatment of constant IC<sub>30</sub> values of HDAC inhibitors and increasing doses of autophagy modulators for EGI-1 cell for 48h (n=3). The combinations of the Chloroquine IC<sub>30</sub> (5.14  $\mu$ M) and a) SAHA IC<sub>30</sub> (0.43  $\mu$ M), b) MS-275 IC<sub>30</sub> (0.53 nM) c) Romidepsin IC<sub>30</sub> (0.74 nM), respectively. The combinations of the Nocodazole IC<sub>30</sub> (2.15  $\mu$ M) and d) SAHA IC<sub>30</sub> (0.43  $\mu$ M), e) MS-275 IC<sub>30</sub> (0.53 nM) f) Romidepsin IC<sub>30</sub> (0.74 nM), respectively. The combinations of the PP242 IC<sub>30</sub> (9.02 nM) and g) SAHA IC<sub>30</sub> (0.43  $\mu$ M), h) MS-275 IC<sub>30</sub> (0.53 nM), i) Romidepsin IC<sub>30</sub> (0.74 nM), respectively. Each set of experiments averaged and statistical analysis was performed using two-way ANOVA by Dunnett's test. Data are presented as the mean  $\pm$  standard error. W: Water (\*= P  $\leq$  0.05, \*\*= P  $\leq$  0.01, \*\*\*= P  $\leq$  0.001, \*\*\*\*= P  $\leq$  0.0001).





**Figure 3.12** The combination treatment of constant IC<sub>30</sub> values of HDAC inhibitors and increasing doses of autophagy modulators for HepG2 cell for 48h (n=3). The combinations of the Chloroquine IC<sub>30</sub> (4.1 μM) and a) SAHA IC<sub>30</sub> (1.2 μM), b) MS-275 IC<sub>30</sub> (4.3 nM) c) Romidepsin IC<sub>30</sub> (0.94 nM), respectively. The combinations of sthe Nocodazole IC<sub>30</sub> (4.7 μM) and d) SAHA IC<sub>30</sub> (1.2 μM), e) MS-275 IC<sub>30</sub> (4.3 nM) f) Romidepsin IC<sub>30</sub> (0.94 nM), respectively. The combinations of the PP242 IC<sub>30</sub> (4.4 μM) and g) SAHA IC<sub>30</sub> (1.2 μM), h) MS-275 IC<sub>30</sub> (4.3 nM), i) Romidepsin IC<sub>30</sub> (0.94 nM), respectively. Each set of experiments averaged and statistical analysis was performed using two-way ANOVA by Dunnett's test. Data are presented as the mean ± standard error. W: Water (\*= P ≤ 0.05, \*\*= P ≤ 0.01, \*\*\*= P ≤ 0.001, \*\*\*\*= P ≤ 0.0001).

According to the results of IC<sub>30</sub> combination therapy experiments, the percentage of viable cells for all cell lines in the Table 3.3.

When the cells were treated with single HDAC inhibitors, the growth inhibition of 30% to 55% for TFK-1 cell line and of 20% and 85% for EGI-1 cell line was observed. While single chloroquine, PP242, and nocodazole were applied and it was observed growth inhibition 15% to 20% to 50% in TFK-1 cell lines, respectively. In a similar way, while single chloroquine does not have an impact on EGI-1 cell lines, single PP242 and nocodazole caused growth inhibition 20% and 35%, respectively.

When compared with single HDACis and single chloroquine and PP242 on the TFK-1 cell lines, the combination the chloroquine: MS-275, chloroquine: SAHA, chloroquine: Romidepsin is not found to be significant effect according to single treatments. On the contrary, compared nocodazole: MS-275, nocodazole: SAHA, and nocodazole: Romidepsin with the single HDACis and single nocodazole has seen an increase in the growth inhibition 12%, 28%, and 13%, respectively.

While Nocodazole has inhibited 30% of the cell in the EGI-1 cell line, was not observed a prominent effect in single PP242 and especially chloroquine. In combinations of chloroquine: SAHA, and chloroquine: romidepsin no significant effect was observed according to the single treatments, but, it is increased 17% the inhibition percentage in the chloroquine: MS- 275 treatment. Among the HDACis, and PP242 - HDACis (MS-275, SAHA, Romidepsin) did not show a distinct effect. The nocodazole: MS-275 and nocodazole: SAHA combinations showed inhibition increased of 11% and 15%, respectively.

**Table 3.3** The percentage of the cell proliferation of the IC<sub>30</sub> combinations on TFK-1, EGI-1 and HepG2 cell lines. On the table identified as MS-275 alone, SAHA alone, and Romidepsin alone the orange color, Chloroquine alone, Nocodazole alone, and PP242 alone the green color, and combination of IC<sub>30</sub> HDACis and IC<sub>30</sub> autophagy modulators the blue color.

Cell lines	TFK-1			EGI-1			HepG2		
	MS-275	SAHA	Romidepsin	MS-275	SAHA	Romidepsin	MS-275	SAHA	Romidepsin
Chloroquine	32	51	40	68	24	77	59	40	27
	1	15	10	0	0	0	21	50	14
	33	52	43	85	19	79	72	58	51
Nocodazole	40	35	44	73	28	75	57	44	49
	47	54	50	33	23	30	38	48	44
	52	63	57	84	43	76	66	58	69
PP242	39	32	49	79	53	86	43	43	24
	8	4	19	12	22	3	21	40	42
	39	44	52	79	49	83	66	59	57

On the other hand, the Nocodazole: MS-275, Nocodazole: SAHA, and Nocodazole: Romidepsin 11%, 14%, 20% increase in proliferation on HepG2 cells, respectively.

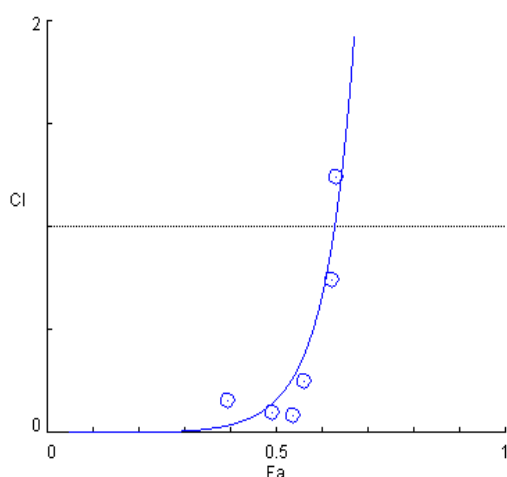
The Nocodazole inhibited the cell growth prominently when combined HDACis for both TFK-1 and EGI-1 cell lines. Therefore, in the further experiments, we focused on the Nocodazole - HDACis (MS-275, SAHA, and Romidepsine) combinations.

### **3.5 The synergistic effects of the combinations of the Nocodazole – HDAC inhibitors**

In order to investigate the combinatorial effects of the inhibitors, a method called CompuSyn analysis was used to detect the synergism, additivity or antagonism. A combination index (CI) is the indicative of CI<1 - synergistic, CI=1.0-1.1 - additive, or CI>1.1 - antagonistic effects.

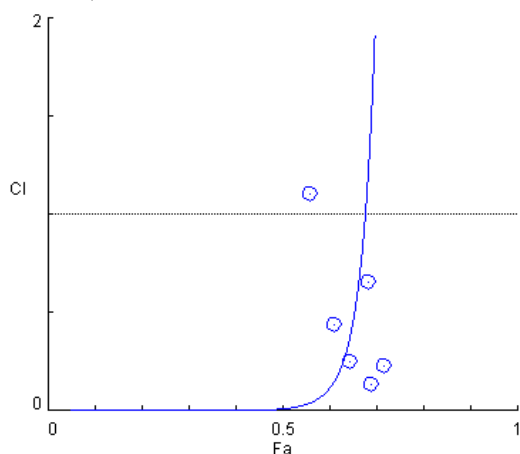
Our results showed that the concentration of the IC<sub>30</sub> dose of nocodazole with MS-275 and Romidepsin have synergistic effects on the EGI-1 cell (Figure 3.13d, and Figure 3.13f). However, the nocodazole: SAHA combination showed antagonistic effects (Figure 3.13e). All concentrations except higher doses of nocodazole with IC<sub>30</sub> doses of the HDACis showed synergistic effects on the TFK-1 cell (Figure 3.13a, 3.13b and 3.13c).

a) TFK-1 MS-275 & Nocodazole



CI values for actual experimental points:		
Total Dose	Fa	CI Value
0.0135	0.39476	0.15386
0.0535	0.49176	0.09705
0.1035	0.53734	0.08016
0.5035	0.56062	0.25159
5.0035	0.62367	0.73928
10.0035	0.63240	1.24181
20.0035	0.63628	2.29697

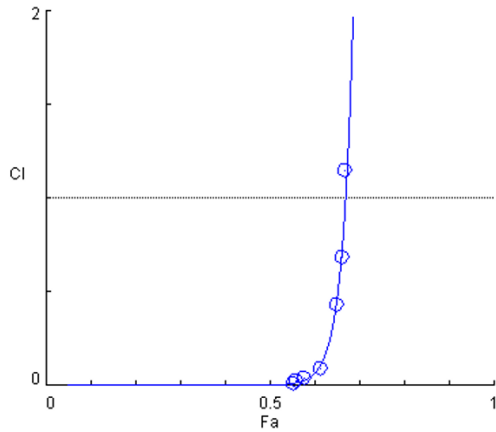
b) TFK-1 Saha & Nocodazole



CI values for actual experimental points:		
Total Dose	Fa	CI Value
2.26	0.55915	1.10215
2.3	0.61183	0.43653
2.35	0.64418	0.25157
2.75	0.69039	0.13268
7.25	0.71534	0.23162
12.25	0.68392	0.65930
22.25	0.63678	2.71316

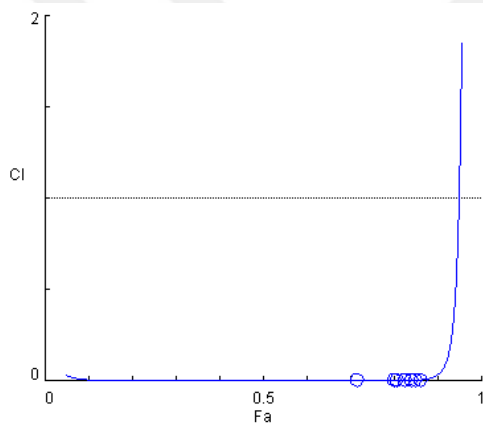


c) TFK-1 Romidepsin & Nocodazole



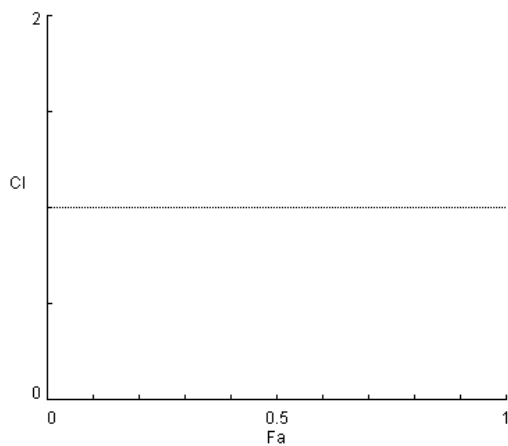
CI values for actual experimental points:		
Total Dose	Fa	CI Value
0.0137	0.55366	0.00771
0.0537	0.55840	0.02762
0.1037	0.57645	0.03787
0.5037	0.61349	0.08987
5.0037	0.64957	0.43330
10.0037	0.66097	0.68485
20.0037	0.66952	1.14525

d) EGI-1 MS-275 & Nocodazole

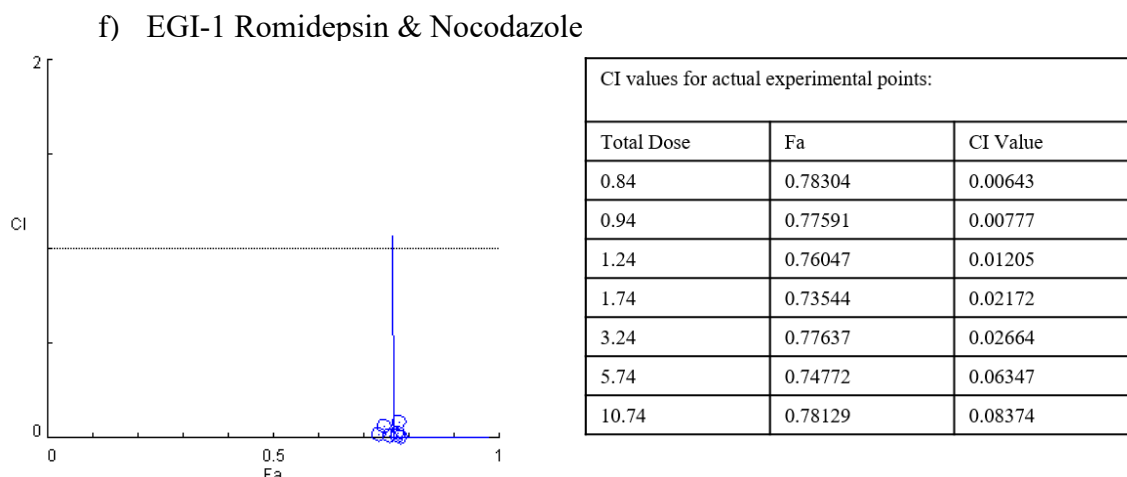


CI values for actual experimental points:		
Total Dose	Fa	CI Value
0.63	0.80019	5.90E-4
0.73	0.82683	4.84E-4
1.03	0.80780	8.76E-4
1.53	0.71741	0.00380
3.03	0.84015	0.00166
5.53	0.86204	0.00217
10.53	0.84872	0.00510

e) EGI-1 Saha & Nocodazole



CI values for actual experimental points:		
Total Dose	Fa	CI Value
0.53	0.18678	90627.5
0.63	0.26878	1854.71
0.93	0.45935	2.29507
1.43	0.47806	2.04718
2.93	0.45331	8.70976
5.43	0.45134	17.1652
10.43	0.47159	17.9205



**Figure 3.13 Combination Index (CI) Plots of TFK-1 (a, b, c) and EGI-1 (d, e, f) cell lines treated with combination increased doses of the nocodazole with HDACis. a, d) MS-275: nocodazole, b, e) SAHA: nocodazole, c, f) Romidepsin: nocodazole. CI<1 - synergistic, CI=1.0-1.1 - additive, or CI >1.1 - antagonistic effects.**

### 3.6 Cytostatic Effects of Single Nocodazole and in Combination with HDAC inhibitors on CCA Cells

In order to evaluate the mechanism behind growth inhibitory effects, we investigated the impact of single nocodazole and HDAC inhibitors and the combinations on cell cycle distribution of CCA cells. The cell cycle was assessed by propidium iodide (PI) staining and analyzed by flow cytometry. The percentages of the cells in G0/G1, S, and G2/M phases were determined.

When TFK-1 cells were treated with MS-275, no cell cycle arrest was observed when compared to the control (Figure 3.14a). In response to Romidepsin treatment, the cells were arrested at the S phase (32.6%) when compared to the control (18.5%) (Figure 3.14b). SAHA treated cells were arrested at the S (19.4%) and G2/M (25.6%) phases when compared to the control (Figure 3.14c).

The results of the experiment demonstrated that, Nocodazole treatment arrested prominently at the S and G2/M phases when compared to the control. As a result of these comparisons, the Nocodazole - HDACis (MS-275, SAHA, Romidepsin) combination caused the accumulation of cell population at the S (31.4%, 36.8%, 35.7%, respectively) and G2/M (42.9%, 47.9%, 24.9%, respectively) phases compared to the control S and G2/M phases (Figure 3.14).

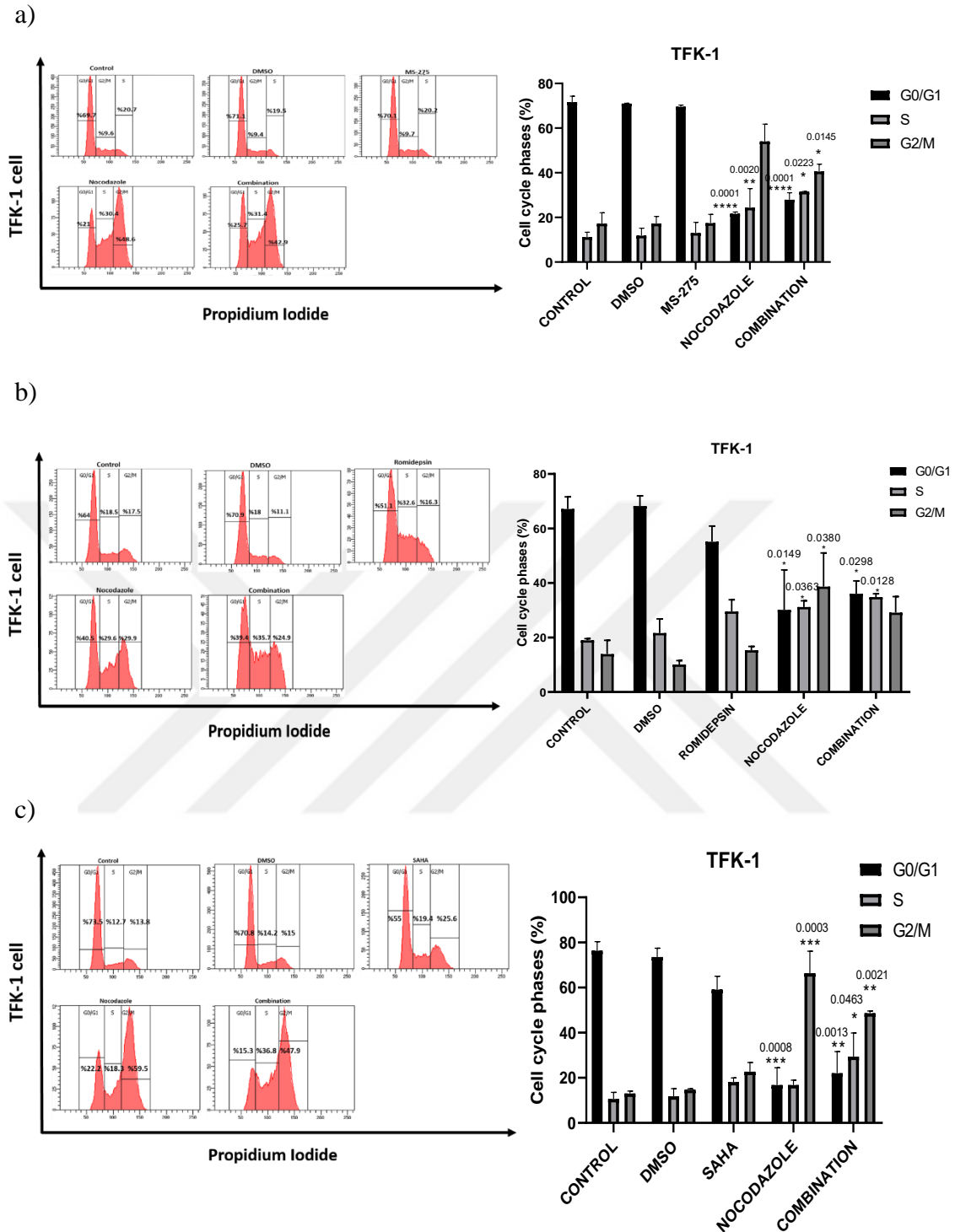


Figure 3.14 Cell cycle distributions of (a) MS-275 IC<sub>30</sub> - Nocodazole IC<sub>30</sub>, (b) Romidepsin IC<sub>30</sub> - Nocodazole IC<sub>30</sub>, and (c) SAHA IC<sub>30</sub> - Nocodazole IC<sub>30</sub> combinations in TFK-1 cells for 48h (n=2).

In EGI-1 cells, while single MS-275, and single SAHA caused a slightly cell cycle arrest at the S phase compared to control (Figure 3.15a, 3.15c), Romidepsin treatment arrested the cells at S (33.8%) phase compared to the control (12.9%) (Figure 3.15b).

Single nocodazole was arrested at the S (23.9%) and G2/M (55.2%) phases compared to the control S (12.9%) and G2/M (8.9%) phases. In conclusion, the Nocodazole - HDACis (MS-275, SAHA, Romidepsin) combination caused an accumulation at the S (32%, 28.4%, 39.6%, respectively) and G2/M (17.7%, 49.2%, 16.7%, respectively) phases compared to the control S (12.9%) and G2/M (8.9%) phases (Figure 3.15).

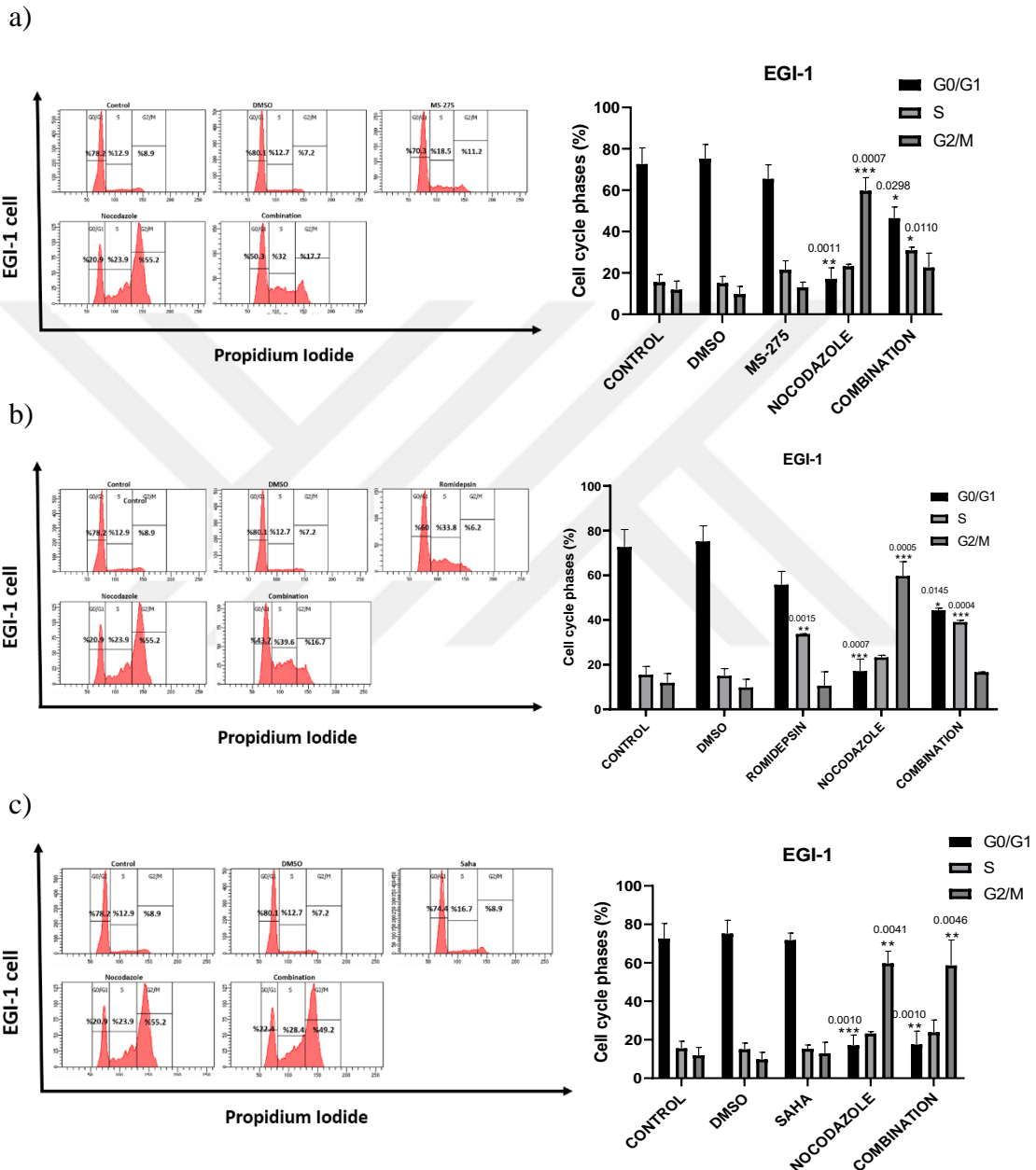
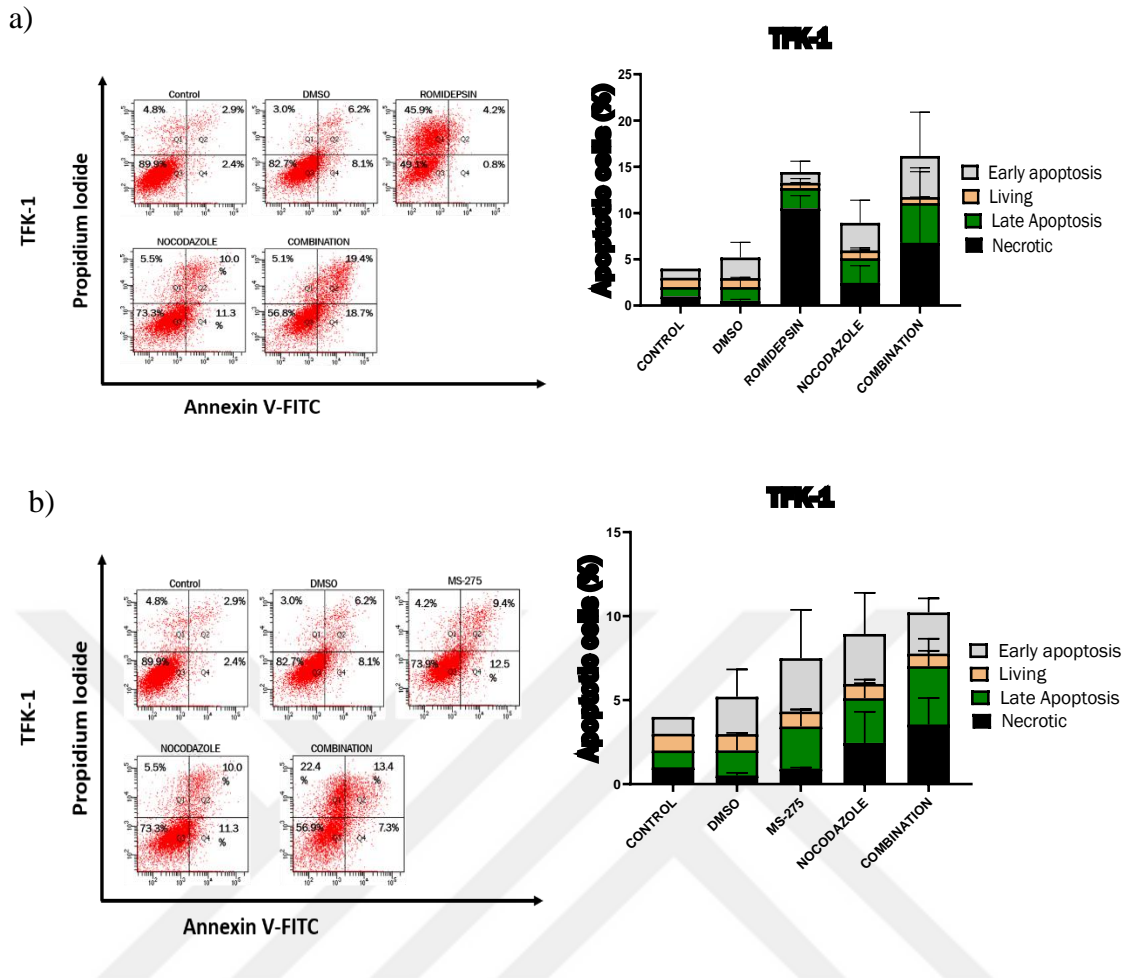


Figure 3.15 Cell cycle distributions of (a) MS-275 IC<sub>30</sub>: Nocodazole IC<sub>30</sub>, (b) Romidepsin IC<sub>30</sub>: Nocodazole IC<sub>30</sub>, and (c) SAHA IC<sub>30</sub>: Nocodazole IC<sub>30</sub> combinations in EGI-1 cells for 48h (n=2).

### **3.7 Apoptotic Effects of Combination Nocodazole and HDACis on CCA**

Phosphatidylserine (PS) molecules are important for apoptotic cell identification, herewith, in order to determine whether the growth inhibitory effect of this combination is due to induction of apoptosis, CCA TFK-1 and EGI-1 cells were incubated with single HDACis IC30, single Nocodazole IC30, and combinations for 48 hours. The percentage of cells encountering apoptosis upon treatments was determined by flow cytometry using Propidium Iodide (PI)-Annexin-V dual staining.

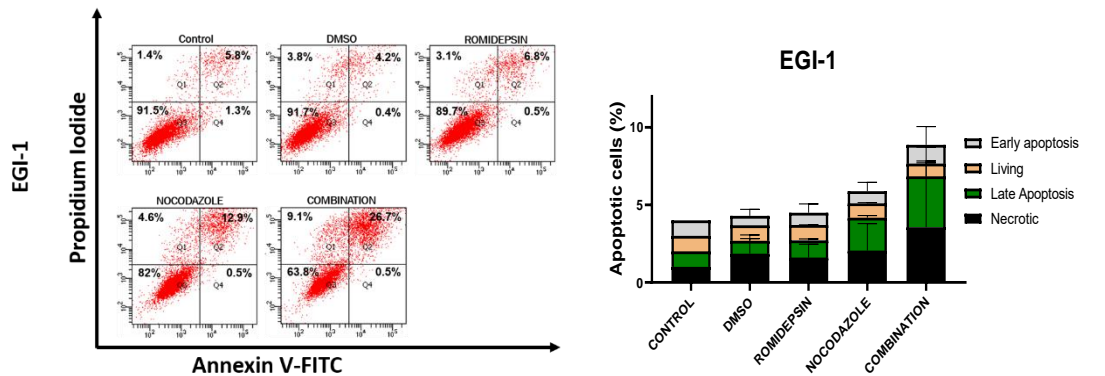
TFK-1 cells were treated with MS-275 (3,5nM), Romidepsin (3,7nM), Nocodazole (2,89  $\mu$ M), and combination; total apoptotic cell population in the Romidepsine-Nocodazole combination (late apoptotic cells + early apoptotic cells) was increased as 16,8%, 33,1% respectively, compared to single Nocodazole and Romidepsin treatment. In the single romidepsin treatment, necrotic cells were increased by 41.1%, compared to control, whereas in the combination, necrotic cells decreased by 40,8% compared to single Romidepsin (Figure 3.16a). The total apoptotic population in a single treatment of the MS-275, and Nocodazole was increased by 16,6% and 16%, respectively, compared to control. But, the combination increased the necrotic cell population approximately 5-fold compared to the control and single treatments (Figure 3.16b).



**Figure 3.16 Apoptotic effects of Romidepsin - Nocodazole (a) and MS-275 Nocodazole (b) on TFK-1 cells (n=2).**

EGI-1 cells were treated with MS-275 (0,53nM), Romidepsin (0,74nM), Nocodazole (2,15  $\mu$ M), and combination; total apoptotic cell population in the Romidepsine-Nocodazole combination (late apoptotic cells + early apoptotic cells) was increased as 13,8%, 19,9% respectively, compared to single Nocodazole and Romidepsin treatment (Figure 3.17a). The total apoptotic and necrotic populations in a single treatment of the MS-275 wasn't shown a significant change compared to the control. In the combination, necrotic and total apoptotic cell populations increased approximately 5-fold and 3-fold, respectively, compared to the control (Figure 3.17b). In the single romidepsin treatment, necrotic cells were observed similarly TFK-1 result. Also, the MS-275-Nocodazole combination wasn't seen to increase compared to single Nocodazole.

a)



b)

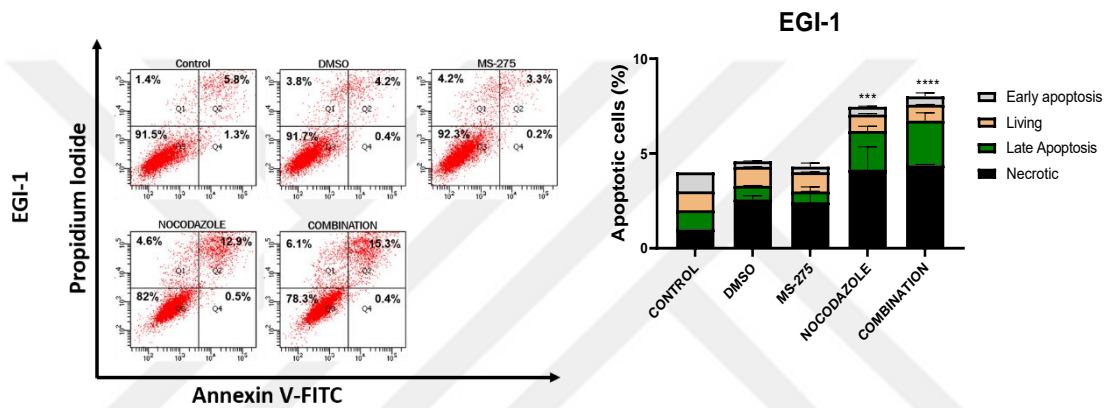


Figure 3.17 Apoptotic effects of Romidepsin - Nocodazole (a) and MS-275 Nocodazole (b) on TFK-1 cells (n=2).

### 3.8 HDACis and Nocodazole combinations induced the acetylation and HDAC levels in CCA cells

To understand the roles of Ac-H3, Ac-H4, total H3, and HDAC1/2 in HDACis and Nocodazole combination-mediated growth inhibition in CCA cells, we checked the alterations in Ac-H3, Ac-H4, total H3, and HDAC1/2 protein levels in TFK-1 and EGI-1 cells in response to IC30 concentration of HDACis and Nocodazole. TFK-1 and EGI-1 cells are treated with a single MS-275 (3,5nM / 0,53nM), a single Romidepsin (3,7nM / 0,74nM), a single Nocodazole (2,89µM / 2,15µM), and HDACis - Nocodazole combination for 48h, respectively. The expression of Ac-H3, Ac-H4, total H3, and HDAC1/2 were analyzed by western blot.

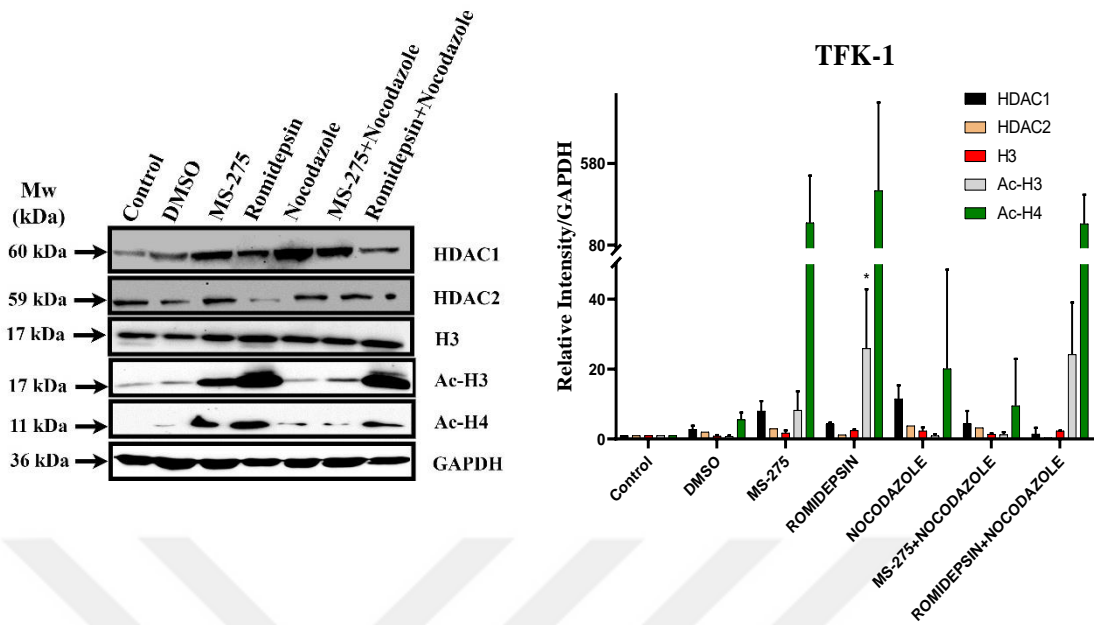
MS-275 and Romidepsin significantly increased Ac-H3 and Ac-H4 levels in TFK-1 cells, compared to control, respectively (Figure 3.18a). Although MS-275 HDAC 1

inhibitor, it is increased 6-fold compared to control. Similarly, Nocodazole increased 14-fold at the HDAC 1 level according to the control. In addition to these, in the MS-275 - Nocodazole combination, the HDAC 1 level was reduced compared to the single Nocodazole. Also, the AcH3/H4 levels in this combination were significantly reduced compared to single MS-275. In the Romidepsin - Nocodazole combination, HDAC 1 / 2 levels decreased compared to the single treatments, and the AcH3 level didn't change compared to Romidepsin. But Ac-H4 level was significantly reduced compared to the Romidepsin.

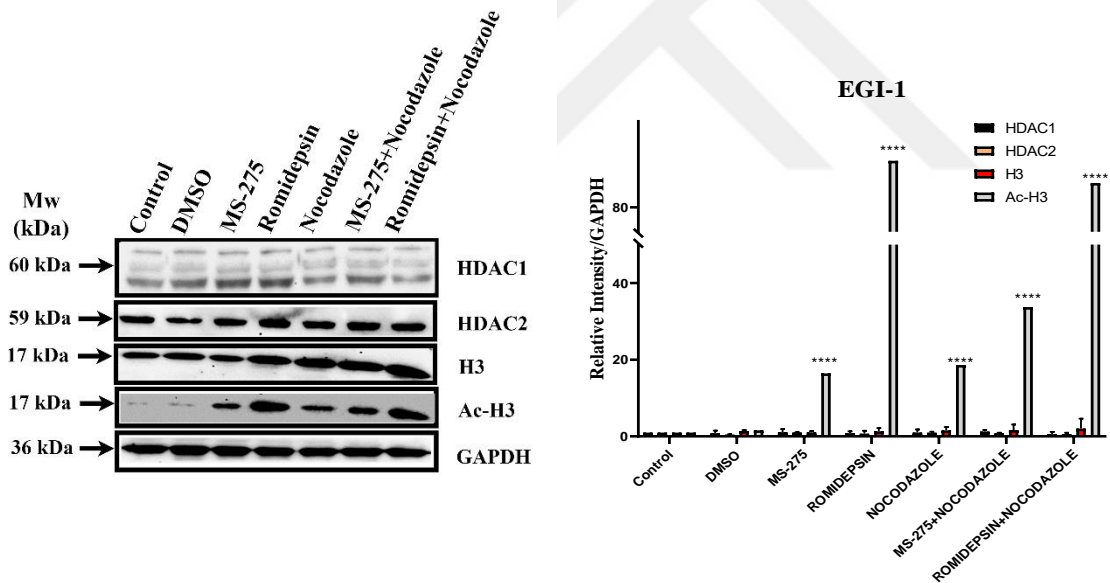
MS-275, Romidepsin, and Nocodazole significantly increased the Ac-H3 levels in EGI-1 cells, compared to control (Figure 18b). But HDAC 1 / 2, and H3 didn't show significant a change compared to control. Contrary to these, the Ac-H3 level for all single treatments was extremely increased compared to control. Despite this increase, Romidepsin - Nocodazole combination reduced of Ac-H3 level compared to the single Romidepsin. But Ac-H3 level of the MS-275 - Nocodazole combination increased compared to the single MS-275 and single Nocodazole.



a)



b)



**Figure 3.18** Changes in AcH3/H4, total H3, and HDAC 1 / 2 (a) in TFK-1, (b) in EGI-1 cells. Gapdh was used as a loading control. Experiments were replicated independently (n=2) and a representative western blot image was used for each set. The protein expression of each group was normalized to Gapdh. For TFK-1 HDAC1, H3, AcH3, Ac-H4 (n=2), HDAC2 (n=1). For EGI-1 HDAC1, HDAC2, H3 (n=2), Ac-H3 (n=1)

# Chapter 4

## Conclusion and Future Prospects

### 4.1. Conclusion

Cholangiocarcinoma is a malignant tumor originating from the biliary tract and is relatively less common than hepatocellular carcinoma, which is another primary tumor of the liver. CCA is categorized as intrahepatic (iCCA) and extrahepatic (eCCA) according to their anatomical localization. There are clinical, pathological, and epidemiological differences between these two groups [151]. Mortality is high because the diagnosis is usually made at advanced stages, radiological imaging is difficult, and due to the lack of an effective non-surgical treatment [33,35].

The TFK-1 and EGI-1 cell lines used in this study belong to distal cholangiocarcinoma which is a subgroup of the extrahepatic cholangiocarcinoma type. Distal cholangiocarcinoma (dCCA) is seen outside the liver which makes up 30% to 40% of eCCAs, and it is histologically well to moderately differentiated adenocarcinoma [29-32].

In recent years, the modifications of histone proteins, which form the basic structure of the nucleosome, have been demonstrated that they have a role in the control of biological processes such as aging and development. Although it has been shown that many genes are silenced with promoter methylation in the hepatocarcinogenesis process, the role of histone code changes is not yet known [153-155]. Histone deacetylase inhibitors (HDACis), which inhibit histone deacetylase enzymes cause the accumulation of acetylation in histone proteins and become defective by changing cellular processes in cancerous cells. High acetylation has been shown to inhibit tumors [152].

In this study, we aimed to investigate the effects of combination of HDAC inhibitors and autophagy modulators on TFK-1 and EGI-1 CCA cell lines. HDAC inhibitors of different classes such as MS-275, Romidepsin, SAHA, Tubastatin A, PCI-34051 for the treatment of CCA cell lines. The growth inhibitory effect of HDACis and autophagy modulators on TFK-1 and EGI-1 cells were evaluated by MTT assay.

Among the inhibitors, SAHA, which was used as a control in our study, was approved by the FDA for the treatment of cutaneous T-cell lymphoma patients. SAHA is known to inhibit the activity of all 11 HDACs classified as class I - II HDACs. Some findings have demonstrated that single SAHA or combination inhibited cells proliferation for various cancer types such as larynx [159], lung [158], breast [156], and different cholangiocarcinoma cell lines [157]. In line with previous studies, SAHA results demonstrated the inhibition of proliferation of TFK-1 and EGI-1 cell lines of the CCA.

Romidepsin, which is another FDA-approved inhibitor, reduced proliferation in the treatment of TFK-1 and EGI-1 cells and of different CCA cell lines shows that our results are in line with the findings in the literature [161]. Another synthetic HDAC inhibitor, MS-275, potently inhibits histone deacetylases in several human tumor cells which supports our findings that are showing reduced cell proliferation TFK-1 and EGI-1 cells treated with MS-275 alone and some combinations [160]. In TFK-1 and EGI-1 cells, the selective HDAC8 inhibitor, PCI-34051, and the selective HDAC6 inhibitor, Tubastatin A, showed a significant reduction at 10  $\mu$ M and 50  $\mu$ M in both cell lines. As a result of these findings, MS-275 and romidepsin showed the best effect at low micro and nanomolar levels in our cells.

Cancer cells have evolved to adapt to themselves to survive by autophagy, which is a multistage death mechanism. Also, it has been reported that autophagy modulators used in CCA cells promote cell death. [162, 163]. The best activity obtained by using the following autophagy modulators in TFK-1 and EGI-1; Chloroquine and Ammonium chloride for autophagosomal degradation, Nocodazole and Vinblastine for autophagosome-lysosome fusion, and PP242 for mTOR inhibitor.

As a result of combinations of the HDACis with increasing doses of autophagy modulators, and of HDACis with autophagy modulators, the best combinatorial effect was observed in Nocodazole combinations. According to the isobologram analysis, we propose, that using a high concentration in combination Nocodazole and HDACis (MS-275, SAHA, and Romidepsin) is not recommended. Because it seems to have an antagonistic effect to treat with SAHA for the EGI-1 cell. These findings are consistent with research showing that the combination of HDACis and autophagy modulators provide a synergistic effect [164, 165].

The cell cycle studies were performed to reveal how MS-275, SAHA, and Romidepsin with Nocodazole suppressed the cell proliferation and regulated cell cycle in TFK-1 and EGI-1 cells.

Nocodazole which is a prototypic microtubule inhibitor, has been shown to suppresses the G2/M phase. The results in our study are consistent with the results obtained in lung and different cholangiocarcinoma cell lines [166-168].

When the EGI-1 cells are treated with MS-275 inhibitor doses between 0.1  $\mu\text{M}$ / 1  $\mu\text{M}$  the cells accumulated significantly in the G0/G1 phase and an increase in the cell population was observed in G2/M phase. It has shown that accumulation in the G0/G1 phase for TFK-1 cells under the same conditions but showed more prominent suppression at the G2/M phase compared with the EGI-1 [160]. However, in our study, MS-275 arrested slightly in S and G2/M phases in EGI-1 cells compared to control, TFK-1 and EGI-1 cells treated with 3.5 nM/ 0.53 nM, respectively. It did not show any change in the TFK-1 cell. In the combination of MS-275 and Nocodazole, S and G2/M phases were suppressed compared to the control group in both cell lines. When the two studies were compared, they showed that differences could happen in cell lines that belong to the same cancer type. In addition, using higher doses treatment of MS-275 showed that more significant results can be achieved.

It was observed that the percentage of suppression in the G2/M phase increased with increasing concentrations with Romidepsin (0-20nM) on different CCA cell lines [161]. Our results demonstrated the accumulation of the TFK-1 cells in S and G2/M phase (0.0037 $\mu\text{M}$ ) compared to the control and there was accumulation in the S phase and slightly in the G2/M phase in the EGI-1 cell (0.74nM). The increased percentage of the G2/M phase in the treatment of Romidepsin in CCA cells were observed with increasing doses. In the combination of Romidepsin: Nocodazole, there was an increase in the percentages of the S and G2/M phases compared to single Romidepsin.

According to the results obtained in response to SAHA treatment, there was suppression at the S and G2/M phases for both cell lines, however in the EGI-1, the arrest at the G2/M phase was more prominent. Studies the SAHA therapy showed suppression in the G2/M phases in lung, prostate, and breast cancer types [169,170].

Single Romidepsin treatment was shown to lead to a dose- and time-dependent induction of total apoptosis and necrosis [176-178]. Romidepsin increases necrotic population levels on TFK-1. Contrary to the findings in the Romidepsin apoptosis result of the TFK-1 we did not observe an increasing necrotic population on the EGI-1. Nocodazole showed apoptotic cell death on the CCA cell lines like in different cancer types [179]. Du et al, MS-275-treatment was shown to induce dose-dependent apoptosis on the malignant ascites cells [180]. But in our study, MS-275 did not cause remarkable

apoptosis. However, in the literature studies, in line with the ideas of increased dose and time-dependent, it can be concluded that can induce apoptosis on the TFK-1 and EGI-1 cell lines.

In clinical or laboratory studies, the role of Romidepsin and MS-275 has been shown in peripheral blood mononuclear cells, one marrow mononuclear cells, and many cancer types. In these studies, they showed an increase in the protein acetylation level Ac-H3 and Ac-H4. And a similar conclusion was reached by our results [182-184]. On the other hand, we purpose to observe an increase in the level of acetylation with the combination of nocodazole, but our results were not observed an increase outside the combination with MS-275.

In conclusion, the limited treatment options in CCA shows that investigating new approaches is necessary. In summary, combinations study of different HDAC inhibitors and autophagy modulators has been shown in this study. Our results show that HDACis and autophagy modulators have proliferation inhibitory effect on CCA cell lines. This study creates a new and unique approach for CCA targeting thanks to the synergistic effect that will emerge with the combination of autophagy and HDAC inhibitors. The importance and impact of this study is that we showed for the first that the fine-tuning of autophagy and HDACis can specifically target cancerous cells.

## **4.2 Societal Impact and Contribution to Global Sustainability**

Cholangiocarcinoma (CCA), also known as biliary tract cancer, is a heterogeneous group of malignancies formed by the differentiation of epithelial cells in the biliary tract. CCA is the second most common primary liver tumor and it has both an increasing rate and high mortality worldwide with its late diagnosis, refractory type, and aggressiveness. CCA is categorized as intrahepatic (iCCA) and extrahepatic (eCCA) according to their anatomical localization. There are clinical, pathological, and epidemiological differences between these two groups. It is not easy to treat cholangiocarcinoma due to of late diagnosis, refractory type, and aggressiveness even though approved targeted therapies. Mortality is high because the diagnosis is usually made at advanced stages, radiological imaging is difficult, and due to the lack of an effective non-surgical treatment. Therefore, it is important to find a novel integrative solution to treat the disease.

HDACis are currently under investigation in phases I, II, and III of clinical trials for many cancer types. Their effects are connected to autophagic cell death. Nevertheless,

their role as autophagy activators or blockers has been uncertain. The expression of histone deacetylases (HDACs) has been associated with poor prognosis and survival in patients of cholangiocarcinoma. HDAC inhibitors are sensitizing CCA-resistant cell lines to chemotherapeutic drugs. Furthermore, CCA has manipulated autophagy and utilized it as an escape mechanism against chemotherapeutics. Thus, given the controversial effect of HDACis on autophagy, it is essential to understand the molecular mechanism and the effects of HDACis in the context of CCA.

Combination of the HDAC inhibitors and autophagy modulators have resulted shown that has an effect on CCA cell lines. This study, thanks to the synergistic effect that will emerge with the combination of autophagy and HDAC inhibitors, creates a new and unique approach for CCA targeting. The importance of this study is that we showed for the first that the fine-tuning of autophagy and HDACis can specifically target cancerous cells.

### **4.3 Future Prospects**

Further studies are required in order to achieve a more mechanistic understanding of the effect of HDAC inhibition and autophagy modulation. This study could be a good starting point to investigate the crosstalk between HDAC inhibitors and autophagy modulators would be investigated in more detail by using in vitro and in vivo models of Cholangiocarcinoma. The effects determined in this study could be investigated at the molecular level.

# BIBLIOGRAPHY

- [1] Y. Yan, G. Guo, J. Huang *et al.*, “Current understanding of extrachromosomal circular DNA in cancer pathogenesis and therapeutic resistance,” *Journal of Hematology & Oncology*, vol. 13, no. 1, pp. 124, 2020/09/14, (2020).
- [2] J. F. Alhmoud, J. F. Woolley, A.-E. Al Moustafa *et al.*, “DNA Damage/Repair Management in Cancers,” *Cancers*, vol. 12, no. 4, pp. 1050, (2020).
- [3] C. Bernstein, A. R. Prasad, V. Nfonsam, H. Bernstein, “New Research Directions in DNA Repair”, (2013).
- [4] H. Sung, J. Ferlay, R. L. Siegel *et al.*, “Global Cancer Statistics 2020: GLOBOCAN Estimates of Incidence and Mortality Worldwide for 36 Cancers in 185 Countries,” *CA Cancer J Clin*, vol. 71, no. 3, pp. 209-249, May, (2021).
- [5] H. Nagai, and Y. H. Kim, “Cancer prevention from the perspective of global cancer burden patterns,” *J Thorac Dis*, vol. 9, no. 3, pp. 448-451, Mar, (2017).
- [6] S. H. Hassanpour, and M. Dehghani, “Review of cancer from perspective of molecular,” *Journal of Cancer Research and Practice*, vol. 4, no. 4, pp. 127-129, 2017/12/01/, (2017).
- [7] L. A. Torre, R. L. Siegel, E. M. Ward *et al.*, “Global Cancer Incidence and Mortality Rates and Trends—An Update,” *Cancer Epidemiology Biomarkers & Prevention*, vol. 25, no. 1, pp. 16-27, (2016).
- [8] D. M. Parkin, “Global cancer statistics in the year 2000,” *The Lancet Oncology*, vol. 2, no. 9, pp. 533-543, (2001).
- [9] J. Balogh, D. Victor, 3rd, E. H. Asham *et al.*, “Hepatocellular carcinoma: a review,” *J Hepatocell Carcinoma*, vol. 3, pp. 41-53, (2016).
- [10] D. Sia, A. Villanueva, S. L. Friedman *et al.*, “Liver Cancer Cell of Origin, Molecular Class, and Effects on Patient Prognosis,” *Gastroenterology*, vol. 152, no. 4, pp. 745-761, (2017).
- [11] E. Brunt, S. Aishima, P. A. Clavien *et al.*, “cHCC-CCA: Consensus terminology for primary liver carcinomas with both hepatocytic and cholangiocytic differentiation,” *Hepatology*, vol. 68, no. 1, pp. 113-126, Jul, (2018).
- [12] I. Joo, H. Kim, and J. M. Lee, “Cancer stem cells in primary liver cancers: pathological concepts and imaging findings,” *Korean J Radiol*, vol. 16, no. 1, pp. 50-68, Jan-Feb, (2015).
- [13] D. H. Ahn, and T. Bekaii-Saab, “Biliary cancer: intrahepatic cholangiocarcinoma vs. extrahepatic cholangiocarcinoma vs. gallbladder cancers: classification and therapeutic implications,” *Journal of Gastrointestinal Oncology*, vol. 8, no. 2, pp. 293-301, (2016).

- [14] J. M. Banales, V. Cardinale, G. Carpino *et al.*, “Cholangiocarcinoma: current knowledge and future perspectives consensus statement from the European Network for the Study of Cholangiocarcinoma (ENS-CCA),” *Nature Reviews Gastroenterology & Hepatology*, vol. 13, no. 5, pp. 261-280, 2016/05/01, (2016).
- [15] S. A. Khan, S. Tavolari, and G. Brandi, “Cholangiocarcinoma: Epidemiology and risk factors,” *Liver International*, vol. 39, no. S1, pp. 19-31, (2019).
- [16] V. Mahadevan, “Anatomy of the gallbladder and bile ducts,” *Surgery (Oxford)*, vol. 38, no. 8, pp. 432-436, 2020/08/01/, (2020).
- [17] M. Strazzabosco, and L. Fabris, “Functional anatomy of normal bile ducts,” *Anat Rec (Hoboken)*, vol. 291, no. 6, pp. 653-60, Jun, (2008).
- [18] K.-M. Chan, C.-Y. Tsai, C.-N. Yeh *et al.*, “Characterization of intrahepatic cholangiocarcinoma after curative resection: outcome, prognostic factor, and recurrence,” *BMC Gastroenterology*, vol. 18, no. 1, pp. 180, 2018/12/04, (2018).
- [19] S. Buettner, J. L. A. van Vugt, J. N. Ijzermans *et al.*, “Intrahepatic cholangiocarcinoma: current perspectives,” *OncoTargets and therapy*, vol. 10, pp. 1131-1142, (2017).
- [20] C. Mosconi, A. Gramenzi, S. Ascanio *et al.*, “Yttrium-90 radioembolization for unresectable/recurrent intrahepatic cholangiocarcinoma: a survival, efficacy and safety study,” *British journal of cancer*, vol. 115, no. 3, pp. 297-302, (2016).
- [21] C. O. Menias, V. R. Surabhi, S. R. Prasad *et al.*, “Mimics of Cholangiocarcinoma: Spectrum of Disease,” *RadioGraphics*, vol. 28, no. 4, pp. 1115-1129, (2008).
- [22] S. A. Khan, H. C. Thomas, B. R. Davidson *et al.*, “Cholangiocarcinoma,” *The Lancet*, vol. 366, no. 9493, pp. 1303-1314, (2005).
- [23] R. Seidensticker, J. Ricke, and M. Seidensticker, “Integration of chemoembolization and radioembolization into multimodal treatment of cholangiocarcinoma,” *Best Practice & Research Clinical Gastroenterology*, vol. 29, no. 2, pp. 319-332, 2015.
- [24] P. D. Q. A. T. E. Board, *PDQ Cancer Information Summaries*, (2002).
- [25] V. Cardinale, R. Semeraro, A. Torrice *et al.*, “Intra-hepatic and extra-hepatic cholangiocarcinoma: New insight into epidemiology and risk factors,” *World journal of gastrointestinal oncology*, vol. 2, no. 11, pp. 407-416, (2010).
- [26] G. Klatskin, “Adenocarcinoma of the hepatic duct at its bifurcation within the porta hepatis: An unusual tumor with distinctive clinical and pathological features,” *The American Journal of Medicine*, vol. 38, no. 2, pp. 241-256, 1965/02/01/, (1965).
- [27] N. F. Esnaola, J. E. Meyer, A. Karachristos *et al.*, “Evaluation and management of intrahepatic and extrahepatic cholangiocarcinoma,” *Cancer*, vol. 122, no. 9, pp. 1349-1369, (2016).



- [28] N. Katabi, J. Torres, and D. S. Klimstra, "Intraductal Tubular Neoplasms of the Bile Ducts," *The American Journal of Surgical Pathology*, vol. 36, no. 11, pp. 1647-1655, (2012).
- [29] J. W. Valle, I. Borbath, S. A. Khan *et al.*, "Biliary cancer: ESMO Clinical Practice Guidelines for diagnosis, treatment and follow-up" *Annals of Oncology*, vol. 27, pp. 28-37, (2016).
- [30] B. Blechacz, M. Komuta, T. Roskams *et al.*, "Clinical diagnosis and staging of cholangiocarcinoma," *Nature reviews. Gastroenterology & hepatology*, vol. 8, no. 9, pp. 512-522, (2011).
- [31] J. H. Kim, M.-J. Kim, J.-J. Chung *et al.*, "Differential Diagnosis of Periapillary Carcinomas at MR Imaging," *RadioGraphics*, vol. 22, no. 6, pp. 1335-1352, (2002).
- [32] C. G. Ethun, A. G. Lopez-Aguilar, T. M. Pawlik *et al.*, "Distal Cholangiocarcinoma and Pancreas Adenocarcinoma: Are They Really the Same Disease? A 13-Institution Study from the US Extrahepatic Biliary Malignancy Consortium and the Central Pancreas Consortium," *J Am Coll Surg*, vol. 224, no. 4, pp. 406-413, Apr, (2017).
- [33] T. Patel, "Cholangiocarcinoma--controversies and challenges," *Nature reviews. Gastroenterology & hepatology*, vol. 8, no. 4, pp. 189-200, (2011).
- [34] B. R. A. Blechacz, and G. J. Gores, "Cholangiocarcinoma," *Clinics in Liver Disease*, vol. 12, no. 1, pp. 131-150, 2008/02/01/, (2008).
- [35] A. Vogel, H. Wege, K. Caca *et al.*, "The diagnosis and treatment of cholangiocarcinoma," *Deutsches Arzteblatt international*, vol. 111, no. 44, pp. 748-754, (2014).
- [36] J. B. Kuhlmann, and H. E. Blum, "Locoregional therapy for cholangiocarcinoma," *Curr Opin Gastroenterol*, vol. 29, no. 3, pp. 324-8, May, (2013).
- [37] S. A. Alqahtani, and M. Colombo, "Systemic therapy for advanced cholangiocarcinoma: new options on the horizon," *Hepatoma Research*, vol. 6, pp. 70, (2020).
- [38] H. Takeshima, and T. Ushijima, "Accumulation of genetic and epigenetic alterations in normal cells and cancer risk," *npj Precision Oncology*, vol. 3, no. 1, pp. 7, 2019/03/06, (2019).
- [39] K. Nepali, and J.-P. Liou, "Recent developments in epigenetic cancer therapeutics: clinical advancement and emerging trends," *Journal of Biomedical Science*, vol. 28, no. 1, pp. 27, 2021/04/12, (2021).
- [40] S. Saijyo, T. Kudo, M. Suzuki *et al.*, "Establishment of a new extrahepatic bile duct carcinoma cell line, TFK-1," *Tohoku J Exp Med*, vol. 177, no. 1, pp. 61-71, Sep, (1995).

- [41] Zach. S, Birgin. E, "Primary Cholangiocellular Carcinoma Cell Lines," *J. Stem Cell Res. Transplant*, , 2, 1013, (2015).
- [42] I. Lacal, and R. Ventura, "Epigenetic Inheritance: Concepts, Mechanisms and Perspectives," *Frontiers in Molecular Neuroscience*, vol. 11, no. 292, (2018).
- [43] C. Deans, and K. A. Maggert, "What do you mean, "epigenetic"?", *Genetics*, vol. 199, no. 4, pp. 887-896, 2015.
- [44] N. M. Al Aboud, C. Tupper, and I. Jialal, "Genetics, Epigenetic Mechanism," *StatPearls*, Treasure Island (FL), (2021).
- [45] S. B. Baylin, and P. A. Jones, "A decade of exploring the cancer epigenome - biological and translational implications," *Nat Rev Cancer*, vol. 11, no. 10, pp. 726-34, Sep 23, 2011.
- [46] C. J. O'Rourke, P. Munoz-Garrido, E. L. Aguayo *et al.*, "Epigenome dysregulation in cholangiocarcinoma," *Biochimica et Biophysica Acta (BBA) - Molecular Basis of Disease*, vol. 1864, no. 4, Part B, pp. 1423-1434, (2018).
- [47] A. P. Wolffe, and M. A. Matzke, "Epigenetics: regulation through repression," *Science*, vol. 286, no. 5439, pp. 481-6, (1999).
- [48] Y. Cheng, C. He, M. Wang *et al.*, "Targeting epigenetic regulators for cancer therapy: mechanisms and advances in clinical trials," *Signal Transduction and Targeted Therapy*, vol. 4, no. 1, pp. 62, (2019).
- [49] A. Bird, "DNA methylation patterns and epigenetic memory," *Genes Dev*, vol. 16, no. 1, pp. 6-21, (2002).
- [50] A. Portela, and M. Esteller, "Epigenetic modifications and human disease," *Nat Biotechnol*, vol. 28, no. 10, pp. 1057-68, (2010).
- [51] B. E. Bernstein, A. Meissner, and E. S. Lander, "The mammalian epigenome," *Cell*, vol. 128, no. 4, pp. 669-81, (Feb 23, 2007).
- [52] R. Kanwal, K. Gupta, and S. Gupta, "Cancer epigenetics: an introduction," *Methods Mol Biol*, vol. 1238, pp. 3-25, (2015).
- [53] T. Limpai boon, "Epigenetic aberrations in cholangiocarcinoma: potential biomarkers and promising target for novel therapeutic strategies," *Asian Pac J Cancer Prev*, vol. 13 Suppl, pp. 41-5, (2012).
- [54] T. Vaissière, C. Sawan, and Z. Herceg, "Epigenetic interplay between histone modifications and DNA methylation in gene silencing," *Mutation Research/Reviews in Mutation Research*, vol. 659, no. 1, pp. 40-48, (2008).
- [55] E. J. Nestler, "Epigenetic mechanisms of drug addiction," *Neuropharmacology*, vol. 76 Pt B, no. 0 0, pp. 259-268, (2014).
- [56] K. D. Robertson, "DNA methylation and human disease," *Nat Rev Genet*, vol. 6, no. 8, pp. 597-610, (2005).

- [57] S. Sharma, T. K. Kelly, and P. A. Jones, "Epigenetics in cancer," *Carcinogenesis*, vol. 31, no. 1, pp. 27-36, (2010).
- [58] S. Ray, "The Cell: A Molecular Approach," (2014).
- [59] Q. W. Chen, X. Y. Zhu, Y. Y. Li *et al.*, "Epigenetic regulation and cancer (Review)," *Oncol Rep*, vol. 31, no. 2, pp. 523-532, (2014).
- [60] J. A. Hackett, and M. A. Surani, "DNA methylation dynamics during the mammalian life cycle," *Philosophical transactions of the Royal Society of London. Series B, Biological sciences*, vol. 368, no. 1609, pp. 20110328-20110328, (2013).
- [61] T. H. Bestor, "The DNA methyltransferases of mammals," *Hum Mol Genet*, vol. 9, no. 16, pp. 2395-402, (2000).
- [62] S. Gopalakrishnan, B. O. Van Emburgh, and K. D. Robertson, "DNA methylation in development and human disease," *Mutat Res*, vol. 647, no. 1-2, pp. 30-8, (2008).
- [63] M. Kim, and J. Costello, "DNA methylation: an epigenetic mark of cellular memory," *Experimental & Molecular Medicine*, vol. 49, no. 4, pp. e322-e322, (2017).
- [64] M. Esteller, "CpG island hypermethylation and tumor suppressor genes: a booming present, a brighter future," *Oncogene*, vol. 21, no. 35, pp. 5427-5440, (2002).
- [65] L. Shen, D. Qui, and J. Fang, "[Correlation between hypomethylation of c-myc and c-N-ras oncogenes and pathological changes in human hepatocellular carcinoma]," *Zhonghua Zhong Liu Za Zhi*, vol. 19, no. 3, pp. 173-6, (1997).
- [66] M. Esteller, "Epigenetics in cancer," *N Engl J Med*, vol. 358, no. 11, pp. 1148-59, (2008).
- [67] P. Zhang, K. Torres, X. Liu *et al.*, "An Overview of Chromatin-Regulating Proteins in Cells," *Curr Protein Pept Sci*, vol. 17, no. 5, pp. 401-10, (2016).
- [68] A. Munshi, G. Shafi, N. Aliya *et al.*, "Histone modifications dictate specific biological readouts," *J Genet Genomics*, vol. 36, no. 2, pp. 75-88, (2009).
- [69] B. C. Smith, and J. M. Denu, "Chemical mechanisms of histone lysine and arginine modifications," *Biochimica et biophysica acta*, vol. 1789, no. 1, pp. 45-57, (2009).
- [70] H. P. Chen, Y. T. Zhao, and T. C. Zhao, "Histone deacetylases and mechanisms of regulation of gene expression," *Crit Rev Oncog*, vol. 20, no. 1-2, pp. 35-47, (2015).
- [71] M. Grunstein, "Histone acetylation in chromatin structure and transcription," *Nature*, vol. 389, no. 6649, pp. 349-52, Sep 25, (1997).

- [72] K. Struhl, "Histone acetylation and transcriptional regulatory mechanisms," *Genes Dev*, vol. 12, no. 5, pp. 599-606, Mar 1, (1998).
- [73] B. M. Turner, "Histone acetylation and an epigenetic code," *Bioessays*, vol. 22, no. 9, pp. 836-45, Sep, (2000).
- [74] P. Gujral, V. Mahajan, A. C. Lissaman *et al.*, "Histone acetylation and the role of histone deacetylases in normal cyclic endometrium," *Reproductive Biology and Endocrinology*, vol. 18, no. 1, pp. 84, 2020/08/13, (2020).
- [75] G. E. Zentner, and S. Henikoff, "Regulation of nucleosome dynamics by histone modifications," *Nat Struct Mol Biol*, vol. 20, no. 3, pp. 259-66, Mar, (2013).
- [76] K. Yankulov, "Epigenetics," Cold Spring Harbor Laboratory, 191-204, 2007.
- [77] S. Y. Roth, and C. D. Allis, "Histone acetylation and chromatin assembly: a single escort, multiple dances?," *Cell*, vol. 87, no. 1, pp. 5-8, Oct 4, (1996).
- [78] A. Kazanets, T. Shorstova, K. Hilmi *et al.*, "Epigenetic silencing of tumor suppressor genes: Paradigms, puzzles, and potential," *Biochim Biophys Acta*, vol. 1865, no. 2, pp. 275-88, Apr, (2016).
- [79] P. A. Grant, "A tale of histone modifications," *Genome Biol*, vol. 2, no. 4, pp. Reviews0003, (2001).
- [80] A. J. Bannister, and T. Kouzarides, "Regulation of chromatin by histone modifications," *Cell Research*, vol. 21, no. 3, pp. 381-395, 2011/03/01, (2011).
- [81] A. J. de Ruijter, A. H. van Gennip, H. N. Caron *et al.*, "Histone deacetylases (HDACs): characterization of the classical HDAC family," *Biochem J*, vol. 370, no. Pt 3, pp. 737-49, Mar 15, (2003).
- [82] S. Fu, and R. Kurzrock, "Development of curcumin as an epigenetic agent," *Cancer*, vol. 116, no. 20, pp. 4670-4676, (2010).
- [83] N. Liu, S. Li, N. Wu *et al.*, "Acetylation and deacetylation in cancer stem-like cells," *Oncotarget*, vol. 8, no. 51, pp. 89315-89325, Oct 24, (2017).
- [84] S. C. Hodawadekar, and R. Marmorstein, "Chemistry of acetyl transfer by histone modifying enzymes: structure, mechanism and implications for effector design," *Oncogene*, vol. 26, no. 37, pp. 5528-5540, 2007/08/01, (2007).
- [85] D. Zhao, F. L. Li, Z. L. Cheng *et al.*, "Impact of acetylation on tumor metabolism," *Mol Cell Oncol*, vol. 1, no. 3, pp. e963452, Jul-Sep, (2014).
- [86] L. Icardi, K. De Bosscher, and J. Tavernier, "The HAT/HDAC interplay: multilevel control of STAT signaling," *Cytokine Growth Factor Rev*, vol. 23, no. 6, pp. 283-91, Dec, (2012).
- [87] M. Haberland, R. L. Montgomery, and E. N. Olson, "The many roles of histone deacetylases in development and physiology: implications for disease and therapy," *Nat Rev Genet*, vol. 10, no. 1, pp. 32-42, Jan, (2009).

- [88] T. Hayakawa, and J. Nakayama, "Physiological roles of class I HDAC complex and histone demethylase," *J Biomed Biotechnol*, vol. 2011, pp. 129383, (2011).
- [89] H. M. Prince, M. J. Bishton, and S. J. Harrison, "Clinical studies of histone deacetylase inhibitors," *Clin Cancer Res*, vol. 15, no. 12, pp. 3958-69, Jun 15, (2009).
- [90] M. A. Glozak, and E. Seto, "Histone deacetylases and cancer," *Oncogene*, vol. 26, no. 37, pp. 5420-32, Aug 13, (2007).
- [91] Y. Li, and E. Seto, "HDACs and HDAC Inhibitors in Cancer Development and Therapy," *Cold Spring Harb Perspect Med*, vol. 6, no. 10, Oct 3, (2016).
- [92] W. J. Sun, X. Zhou, J. H. Zheng *et al.*, "Histone acetyltransferases and deacetylases: molecular and clinical implications to gastrointestinal carcinogenesis," *Acta Biochim Biophys Sin (Shanghai)*, vol. 44, no. 1, pp. 80-91, Jan, (2012).
- [93] S. Saji, M. Kawakami, S. Hayashi *et al.*, "Significance of HDAC6 regulation via estrogen signaling for cell motility and prognosis in estrogen receptor-positive breast cancer," *Oncogene*, vol. 24, no. 28, pp. 4531-9, Jun 30, (2005).
- [94] Z. Zhang, H. Yamashita, T. Toyama *et al.*, "HDAC6 expression is correlated with better survival in breast cancer," *Clin Cancer Res*, vol. 10, no. 20, pp. 6962-8, Oct 15, (2004).
- [95] J. H. Choi, H. J. Kwon, B. I. Yoon *et al.*, "Expression profile of histone deacetylase 1 in gastric cancer tissues," *Jpn J Cancer Res*, vol. 92, no. 12, pp. 1300-4, Dec, (2001).
- [96] K. H. Jung, J. H. Noh, J. K. Kim *et al.*, "HDAC2 overexpression confers oncogenic potential to human lung cancer cells by deregulating expression of apoptosis and cell cycle proteins," *J Cell Biochem*, vol. 113, no. 6, pp. 2167-77, Jun, (2012).
- [97] D. A. Moreno, C. A. Scrideli, M. A. Cortez *et al.*, "Differential expression of HDAC3, HDAC7 and HDAC9 is associated with prognosis and survival in childhood acute lymphoblastic leukaemia," *Br J Haematol*, vol. 150, no. 6, pp. 665-73, Sep, (2010).
- [98] M. Ouaïssi, I. Sielezneff, R. Silvestre *et al.*, "High histone deacetylase 7 (HDAC7) expression is significantly associated with adenocarcinomas of the pancreas," *Ann Surg Oncol*, vol. 15, no. 8, pp. 2318-28, Aug, (2008).
- [99] S. Spiegel, S. Milstien, and S. Grant, "Endogenous modulators and pharmacological inhibitors of histone deacetylases in cancer therapy," *Oncogene*, vol. 31, no. 5, pp. 537-551, 2012/02/01, (2012).
- [100] C. B. Yoo, and P. A. Jones, "Epigenetic therapy of cancer: past, present and future," *Nat Rev Drug Discov*, vol. 5, no. 1, pp. 37-50, Jan, (2006).

- [101] J. Gräff, and L.-H. Tsai, "Histone acetylation: molecular mnemonics on the chromatin," *Nature Reviews Neuroscience*, vol. 14, no. 2, pp. 97-111, 2013/02/01, (2013).
- [102] Z. Li, and W. G. Zhu, "Targeting histone deacetylases for cancer therapy: from molecular mechanisms to clinical implications," *Int J Biol Sci*, vol. 10, no. 7, pp. 757-70, (2014).
- [103] T. Eckschlager, J. Plch, M. Stiborova *et al.*, "Histone Deacetylase Inhibitors as Anticancer Drugs," *Int J Mol Sci*, vol. 18, no. 7, Jul 1, (2017).
- [104] L. Ellis, P. W. Atadja, and R. W. Johnstone, "Epigenetics in cancer: targeting chromatin modifications," *Mol Cancer Ther*, vol. 8, no. 6, pp. 1409-20, Jun, (2009).
- [105] J. Arts, S. de Schepper, and K. Van Emelen, "Histone deacetylase inhibitors: from chromatin remodeling to experimental cancer therapeutics," *Curr Med Chem*, vol. 10, no. 22, pp. 2343-50, Nov, (2003).
- [106] Y. Huang, S. Nayak, R. Jankowitz *et al.*, "Epigenetics in breast cancer: what's new?," *Breast Cancer Res*, vol. 13, no. 6, pp. 225, (2011).
- [107] P. A. Marks, and M. Dokmanovic, "Histone deacetylase inhibitors: discovery and development as anticancer agents," *Expert Opin Investig Drugs*, vol. 14, no. 12, pp. 1497-511, Dec, (2005).
- [108] C. J. Yelton, and S. K. Ray, "Histone deacetylase enzymes and selective histone deacetylase inhibitors for antitumor effects and enhancement of antitumor immunity in glioblastoma," *Neuroimmunology and Neuroinflammation*, vol. 5, pp. 46, (2018).
- [109] Y. Sixto-López, J. A. Gómez-Vidal, N. de Pedro *et al.*, "Hydroxamic acid derivatives as HDAC1, HDAC6 and HDAC8 inhibitors with antiproliferative activity in cancer cell lines," *Scientific Reports*, vol. 10, no. 1, pp. 10462, 2020/06/26, (2020).
- [110] A. Grassadonia, P. Cioffi, F. Simiele *et al.*, "Role of Hydroxamate-Based Histone Deacetylase Inhibitors (Hb-HDACIs) in the Treatment of Solid Malignancies," *Cancers (Basel)*, vol. 5, no. 3, pp. 919-42, Jul 25, (2013).
- [111] R. Yadav, P. Mishra, and D. Yadav, "Histone Deacetylase Inhibitors: A Prospect in Drug Discovery," *Turk J Pharm Sci*, vol. 16, no. 1, pp. 101-114, Mar, (2019).
- [112] J. S. Chen, D. V. Faller, and R. A. Spanjaard, "Short-chain fatty acid inhibitors of histone deacetylases: promising anticancer therapeutics?," *Curr Cancer Drug Targets*, vol. 3, no. 3, pp. 219-36, Jun, (2003).
- [113] L. Zhang, J. Zhang, Q. Jiang *et al.*, "Zinc binding groups for histone deacetylase inhibitors," *J Enzyme Inhib Med Chem*, vol. 33, no. 1, pp. 714-721, Dec, (2018).
- [114] S. C. Mwakwari, V. Patil, W. Guarrant *et al.*, "Macrocyclic histone deacetylase inhibitors," *Curr Top Med Chem*, vol. 10, no. 14, pp. 1423-40, (2010).

- [115] P. A. Marks, "The clinical development of histone deacetylase inhibitors as targeted anticancer drugs," *Expert Opin Investig Drugs*, vol. 19, no. 9, pp. 1049-66, Sep, (2010).
- [116] C. J. Yelton, and S. K. Ray, "Histone deacetylase enzymes and selective histone deacetylase inhibitors for antitumor effects and enhancement of antitumor immunity in glioblastoma," *Neuroimmunology and Neuroinflammation*, vol. 5, pp. 46, (2018).
- [117] D. Gozuacik, and A. Kimchi, "Autophagy as a cell death and tumor suppressor mechanism," *Oncogene*, vol. 23, no. 16, pp. 2891-906, Apr 12, (2004).
- [118] R. Mathew, V. Karantza-Wadsworth, and E. White, "Role of autophagy in cancer," *Nature reviews. Cancer*, vol. 7, no. 12, pp. 961-967, (2007).
- [119] W. W.-Y. Yim, and N. Mizushima, "Lysosome biology in autophagy," *Cell discovery*, vol. 6, pp. 6-6, (2020).
- [120] N. Mizushima, and M. Komatsu, "Autophagy: renovation of cells and tissues," *Cell*, vol. 147, no. 4, pp. 728-41, Nov 11, (2011).
- [121] T. Shintani, and D. J. Klionsky, "Autophagy in health and disease: a double-edged sword," *Science*, vol. 306, no. 5698, pp. 990-5, Nov 5, (2004).
- [122] M. Martinez-Vicente, and A. M. Cuervo, "Autophagy and neurodegeneration: when the cleaning crew goes on strike," *Lancet Neurol*, vol. 6, no. 4, pp. 352-61, Apr, (2007).
- [123] N. Mizushima, B. Levine, A. M. Cuervo *et al.*, "Autophagy fights disease through cellular self-digestion," *Nature*, vol. 451, no. 7182, pp. 1069-75, Feb 28, (2008).
- [124] A. L. Anding, and E. H. Baehrecke, "Cleaning House: Selective Autophagy of Organelles," *Dev Cell*, vol. 41, no. 1, pp. 10-22, Apr 10, (2017).
- [125] R. S. Hotchkiss, A. Strasser, J. E. McDunn *et al.*, "Cell death," *N Engl J Med*, vol. 361, no. 16, pp. 1570-83, Oct 15, (2009).
- [126] G. J. Yoshida, "Therapeutic strategies of drug repositioning targeting autophagy to induce cancer cell death: from pathophysiology to treatment," *J Hematol Oncol*, vol. 10, no. 1, pp. 67, Mar 9, (2017).
- [127] Y. S. Rajawat, and I. Bossis, "Autophagy in aging and in neurodegenerative disorders," *Hormones (Athens)*, vol. 7, no. 1, pp. 46-61, Jan-Mar, (2008).
- [128] W. Xu, U. Ocak, L. Gao *et al.*, "Selective autophagy as a therapeutic target for neurological diseases," *Cellular and Molecular Life Sciences*, vol. 78, no. 4, pp. 1369-1392, 2021/02/01, (2021).
- [129] W. Bursch, A. Karwan, M. Mayer *et al.*, "Cell death and autophagy: cytokines, drugs, and nutritional factors," *Toxicology*, vol. 254, no. 3, pp. 147-57, Dec 30, (2008).

- [130] Z. Yang, and D. J. Klionsky, “An overview of the molecular mechanism of autophagy,” *Curr Top Microbiol Immunol*, vol. 335, pp. 1-32, (2009).
- [131] S. Nakamura, and T. Yoshimori, “New insights into autophagosome-lysosome fusion,” *J Cell Sci*, vol. 130, no. 7, pp. 1209-1216, Apr 1, (2017).
- [132] L. Ge, D. Melville, M. Zhang *et al.*, “The ER–Golgi intermediate compartment is a key membrane source for the LC3 lipidation step of autophagosome biogenesis,” *eLife*, vol. 2, pp. e00947, 2013/08/06, (2013).
- [133] Y. Kabeya, N. Mizushima, T. Ueno *et al.*, “LC3, a mammalian homologue of yeast Apg8p, is localized in autophagosome membranes after processing,” *Embo j*, vol. 19, no. 21, pp. 5720-8, Nov 1, (2000).
- [134] F. Reggiori, and C. Ungermann, “Autophagosome Maturation and Fusion,” *J Mol Biol*, vol. 429, no. 4, pp. 486-496, Feb 17, (2017).
- [135] C. Tang, M. J. Livingston, Z. Liu *et al.*, “Autophagy in kidney homeostasis and disease,” *Nature Reviews Nephrology*, vol. 16, no. 9, pp. 489-508, 2020/09/01, (2020).
- [136] X. T. Cheng, B. Zhou, M. Y. Lin *et al.*, “Axonal autophagosomes recruit dynein for retrograde transport through fusion with late endosomes,” *J Cell Biol*, vol. 209, no. 3, pp. 377-86, May 11, (2015).
- [137] H. Brandstaetter, C. Kishi-Itakura, D. A. Tumbarello *et al.*, “Loss of functional MYO1C/myosin 1c, a motor protein involved in lipid raft trafficking, disrupts autophagosome-lysosome fusion,” *Autophagy*, vol. 10, no. 12, pp. 2310-23, (2014).
- [138] E. Fass, E. Shvets, I. Degani *et al.*, “Microtubules support production of starvation-induced autophagosomes but not their targeting and fusion with lysosomes,” *J Biol Chem*, vol. 281, no. 47, pp. 36303-16, Nov 24, (2006).
- [139] L. Jahreiss, F. M. Menzies, and D. C. Rubinsztein, “The itinerary of autophagosomes: from peripheral formation to kiss-and-run fusion with lysosomes,” *Traffic*, vol. 9, no. 4, pp. 574-87, Apr, (2008).
- [140] B. Ravikumar, A. Acevedo-Arozena, S. Imarisio *et al.*, “Dynein mutations impair autophagic clearance of aggregate-prone proteins,” *Nat Genet*, vol. 37, no. 7, pp. 771-6, Jul, (2005).
- [141] D. A. Tumbarello, B. J. Waxse, S. D. Arden *et al.*, “Autophagy receptors link myosin VI to autophagosomes to mediate Tom1-dependent autophagosome maturation and fusion with the lysosome,” *Nat Cell Biol*, vol. 14, no. 10, pp. 1024-35, Oct, (2012).
- [142] L. Yu, Y. Chen, and S. A. Tooze, “Autophagy pathway: Cellular and molecular mechanisms,” *Autophagy*, vol. 14, no. 2, pp. 207-215, (2018).
- [143] Y. C. Kim, and K. L. Guan, “mTOR: a pharmacologic target for autophagy regulation,” *J Clin Invest*, vol. 125, no. 1, pp. 25-32, Jan, (2015).



- [144] A. Iershov, I. Nemazanyy, C. Alkhoury *et al.*, “The class 3 PI3K coordinates autophagy and mitochondrial lipid catabolism by controlling nuclear receptor PPAR $\alpha$ ,” *Nature Communications*, vol. 10, no. 1, pp. 1566, 2019/04/05, (2019).
- [145] A. Arcaro, and A. S. Guerreiro, “The phosphoinositide 3-kinase pathway in human cancer: genetic alterations and therapeutic implications,” *Curr Genomics*, vol. 8, no. 5, pp. 271-306, Aug, (2007).
- [146] G. Song, G. Ouyang, and S. Bao, “The activation of Akt/PKB signaling pathway and cell survival,” *J Cell Mol Med*, vol. 9, no. 1, pp. 59-71, Jan-Mar, (2005).
- [147] K. Pant, E. Peixoto, S. Richard *et al.*, “Role of Histone Deacetylases in Carcinogenesis: Potential Role in Cholangiocarcinoma,” *Cells*, vol. 9, no. 3, Mar 23, (2020).
- [148] H. Perez-Montoyo, “Therapeutic Potential of Autophagy Modulation in Cholangiocarcinoma,” *Cells*, vol. 9, no. 3, pp. 614, (2020).
- [149] T. C. Chou, “Drug combination studies and their synergy quantification using the Chou-Talalay method,” *Cancer Res*, vol. 70, no. 2, pp. 440-6, Jan 15, (2010).
- [150] D. Chen, M. Xu, B. Wu *et al.*, “Histone deacetylases in hearing loss: Current perspectives for therapy,” *Journal of Otology*, vol. 12, no. 2, pp. 47-54, 2017/06/01/, (2017).
- [151] T. Patel, “Cholangiocarcinoma,” *Nat Clin Pract Gastroenterol Hepatol*, vol. 3, no. 1, pp. 33-42, Jan, (2006).
- [152] S. Marsoni, G. Damia, and G. Camboni, “A work in progress: the clinical development of histone deacetylase inhibitors,” *Epigenetics*, vol. 3, no. 3, pp. 164-71, May-Jun, (2008).
- [153] T. Kouzarides, “Chromatin Modifications and Their Function,” *Cell*, vol. 128, no. 4, pp. 693-705, (2007).
- [154] R. N. Aravalli, C. J. Steer, and E. N. Cressman, “Molecular mechanisms of hepatocellular carcinoma,” *Hepatology*, vol. 48, no. 6, pp. 2047-63, Dec, (2008).
- [155] S. S. Thorgeirsson, and J. W. Grisham, “Molecular pathogenesis of human hepatocellular carcinoma,” *Nat Genet*, vol. 31, no. 4, pp. 339-46, Aug, (2002).
- [156] H. Tao, S. Shen, N. Hu, “Effect Of Saha On Proliferation Of Breast Cancer Cells By Activating The Intracellular Apoptosis Pathway,” *Acta Medica Mediterranea*, vol. 37, pp. 311, (2021).
- [157] R. Sriraksa, and T. Limpiboon, “Histone deacetylases and their inhibitors as potential therapeutic drugs for cholangiocarcinoma - cell line findings,” *Asian Pac J Cancer Prev*, vol. 14, no. 4, pp. 2503-8, (2013).
- [158] N. Komatsu, N. Kawamata, S. Takeuchi *et al.*, “SAHA, a HDAC inhibitor, has profound anti-growth activity against non-small cell lung cancer cells,” *Oncol Rep*, vol. 15, no. 1, pp. 187-191, 2006/01/01, (2006).

- [159] A. Grabarska, J. J. Łuszczki, E. Nowosadzka *et al.*, “Histone Deacetylase Inhibitor SAHA as Potential Targeted Therapy Agent for Larynx Cancer Cells,” *Journal of Cancer*, vol. 8, no. 1, pp. 19-28, (2017).
- [160] V. Baradari, M. Höpfner, A. Huether *et al.*, “Histone deacetylase inhibitor MS-275 alone or combined with bortezomib or sorafenib exhibits strong antiproliferative action in human cholangiocarcinoma cells,” *World journal of gastroenterology*, vol. 13, no. 33, pp. 4458-4466, (2007).
- [161] P. Li, L. Liu, X. Dang *et al.*, “Romidepsin Induces G2/M Phase Arrest and Apoptosis in Cholangiocarcinoma Cells,” *Technology in Cancer Research & Treatment*, vol. 19, pp. 1533033820960754, (2020).
- [162] G. Lendvai, T. Szekerczés, I. Illyés *et al.*, “Autophagy activity in cholangiocarcinoma is associated with anatomical localization of the tumor,” *PLoS One*, vol. 16, no. 6, pp. e0253065, (2021).
- [163] H. Perez-Montoyo, “Therapeutic Potential of Autophagy Modulation in Cholangiocarcinoma,” *Cells*, vol. 9, no. 3, pp. 614, (2020).
- [164] R. Rao, R. Balusu, W. Fiskus *et al.*, “Combination of pan-histone deacetylase inhibitor and autophagy inhibitor exerts superior efficacy against triple-negative human breast cancer cells,” *Mol Cancer Ther*, vol. 11, no. 4, pp. 973-83, Apr, (2012).
- [165] L. Gao, X. Sun, Q. Zhang *et al.*, “Histone deacetylase inhibitor trichostatin A and autophagy inhibitor chloroquine synergistically exert anti-tumor activity in H-ras transformed breast epithelial cells,” *Mol Med Rep*, vol. 17, no. 3, pp. 4345-4350, 2018/03/01, (2018).
- [166] S. Yamanaka, N. R. Campbell, F. An *et al.*, “Coordinated effects of microRNA-494 induce G<sub>2</sub>/M arrest in human cholangiocarcinoma,” *Cell cycle (Georgetown, Tex.)*, vol. 11, no. 14, pp. 2729-2738, (2012).
- [167] I. H. Jung, D. E. Jung, Y.-Y. Chung *et al.*, “Iroquois Homeobox 1 Acts as a True Tumor Suppressor in Multiple Organs by Regulating Cell Cycle Progression,” *Neoplasia*, vol. 21, no. 10, pp. 1003-1014, 2019/10/01/, (2019).
- [168] F. Chi, Z. Wang, Y. Li *et al.*, “Knockdown of GINS2 inhibits proliferation and promotes apoptosis through the p53/GADD45A pathway in non-small-cell lung cancer,” *Bioscience Reports*, vol. 40, no. 4, (2020).
- [169] U. Natarajan, T. Venkatesan, V. Radhakrishnan *et al.*, “Cell Cycle Arrest and Cytotoxic Effects of SAHA and RG7388 Mediated through p21(WAF1/CIP1) and p27(KIP1) in Cancer Cells,” *Medicina (Kaunas, Lithuania)*, vol. 55, no. 2, pp. 30, (2019).
- [170] Y. Zhao, D. Yu, H. Wu *et al.*, “Anticancer activity of SAHA, a potent histone deacetylase inhibitor, in NCI-H460 human large-cell lung carcinoma cells in vitro and in vivo,” *Int J Oncol*, vol. 44, no. 2, pp. 451-458, 2014/02/01, (2014).

- [171] H. Hua, Q. Kong, H. Zhang *et al.*, “Targeting mTOR for cancer therapy,” *Journal of Hematology & Oncology*, vol. 12, no. 1, pp. 71, 2019/07/05, (2019).
- [172] E. Donohue, A. Tovey, A. W. Vogl *et al.*, “Inhibition of autophagosome formation by the benzoporphyrin derivative verteporfin,” *The Journal of biological chemistry*, vol. 286, no. 9, pp. 7290-7300, (2011).
- [173] R. Fu, L. Zhang, Y. Li *et al.*, “Saikosaponin D inhibits autophagosome-lysosome fusion and induces autophagy-independent apoptosis in MDA-MB-231 breast cancer cells,” *Molecular medicine reports*, vol. 22, no. 2, pp. 1026-1034, (2020).
- [174] R. Köchl, X. W. Hu, E. Y. Chan *et al.*, “Microtubules facilitate autophagosome formation and fusion of autophagosomes with endosomes,” *Traffic*, vol. 7, no. 2, pp. 129-45, Feb, 2006.
- [175] R. Xu, Z. Ji, C. Xu *et al.*, “The clinical value of using chloroquine or hydroxychloroquine as autophagy inhibitors in the treatment of cancers: A systematic review and meta-analysis,” *Medicine*, vol. 97, no. 46, pp. e12912-e12912, (2018).
- [176] M. Murata, M. Towatari, H. Kosugi *et al.*, “Apoptotic Cytotoxic Effects of a Histone Deacetylase Inhibitor, FK228, on Malignant Lymphoid Cells,” *Japanese Journal of Cancer Research*, vol. 91, no. 11, pp. 1154-1160, (2000).
- [177] W.-J. Sun, H. Huang, B. He *et al.*, “Romidepsin induces G2/M phase arrest via Erk/cdc25C/cdc2/cyclinB pathway and apoptosis induction through JNK/c-Jun/caspase3 pathway in hepatocellular carcinoma cells,” *Biochemical Pharmacology*, vol. 127, pp. 90-100, (2017).
- [178] J. Panicker, Z. Li, C. McMahon *et al.*, “Romidepsin (FK228/depsipeptide) controls growth and induces apoptosis in neuroblastoma tumor cells,” *Cell Cycle*, vol. 9, no. 9, pp. 1830-8, May, (2010).
- [179] A. Masuda, K. Maeno, T. Nakagawa *et al.*, “Association between mitotic spindle checkpoint impairment and susceptibility to the induction of apoptosis by anti-microtubule agents in human lung cancers,” *Am J Pathol*, vol. 163, no. 3, pp. 1109-16, Sep, (2003).
- [180] L. Du, D. Wang, X. Wei *et al.*, “MS275 as Class I HDAC inhibitor displayed therapeutic potential on malignant ascites by iTRAQ-based quantitative proteomic analysis,” *BMC Gastroenterology*, vol. 22, 01/21, (2022).
- [181] E. Hessmann, S. A. Johnsen, J. T. Siveke *et al.*, “Epigenetic treatment of pancreatic cancer: is there a therapeutic perspective on the horizon?,” *Gut*, vol. 66, no. 1, pp. 168-179, Jan, 2017.
- [182] C. Mayr, T. Kiesslich, S. Erber *et al.*, “HDAC Screening Identifies the HDAC Class I Inhibitor Romidepsin as a Promising Epigenetic Drug for Biliary Tract Cancer,” *Cancers*, vol. 13, pp. 3862, (2021).

- [183] C. Grant, F. Rahman, R. Piekarz *et al.*, “Romidepsin: a new therapy for cutaneous T-cell lymphoma and a potential therapy for solid tumors,” *Expert Rev Anticancer Ther*, vol. 10, no. 7, pp. 997-1008, (2010).
- [184] I. Gojo, A. Jiemjit, J. Trepel *et al.*, “Phase 1 and pharmacologic study of MS-275, a histone deacetylase inhibitor, in adults with refractory and relapsed acute leukemias,” *Blood*, vol. 109, pp. 2781-90, (2007).



# CURRICULUM VITAE

2014 – 2019            B.Sc., Molecular Biology and Genetics, Inonu University, Malatya,  
TURKEY

2019 – Present            M.Sc., Bioengineering, Abdullah Gul University, Kayseri,  
TURKEY

## SELECTED PUBLICATIONS AND PRESENTATIONS

J1) M. Yenigül, EB. Gencer Akçok, The Therapeutic Potential of Targeting HDAC6 with Tubastatin A in TFK-1 and EGI-1 Cholangiocarcinoma Cells, Cumhuriyet Science Journal, 2021

J2) M. Yenigül, İ. Akçok, EB. Gencer Akçok, Ethacrynic Acid and Cinnamic Acid Combination Exhibits Selective Anticancer Effects on K562 Chronic Myeloid Leukemia Cells, Molecular Biology Reports, 2022

C1) M. Yenigül, EB. Gencer Akçok, Investigation of Anticancer Effect of Tubastatin A in TFK-1 and EGI-1 Cholangiocarcinoma Cells, 1st International Conference on Experimental Sciences and Biotechnology, 2021

C2) M. Yenigül, EB. Gencer Akçok, The Antiproliferative Effect of Histone Deacetylase Inhibitors and Autophagy Modulators on Cholangiocarcinoma, 17<sup>th</sup> Tıbbi Biyoloji ve Genetik Kongresi, 2021

C3) M. Yenigül, İ. Akçok, EB. Gencer Akçok, Anticancer Activity of Ethacrynic Acid - Cinnamic Acid Combinations on Different Cancer Cell Lines, 10<sup>th</sup> International Drug Chemistry Congress, 2022