



Research paper

Network cost allocation methods for pay-as-bid peer-to-peer energy trading: A comparison

Noorfatima N.^a, Choi Y.^a, Onen A.^{b,c}, Jung J.^{a,*}

^a Department of Energy Systems Research, Ajou University, Suwon, South Korea

^b Department of Electrical-Electronic Engineering, Abdullah Gül University, Kayseri, Turkey

^c Department of Electrical and Computer Engineering, College of Engineering, Sultan Qaboos University, Al-Khoud, Muscat, Oman

ARTICLE INFO

Article history:

Received 2 March 2022

Received in revised form 31 August 2022

Accepted 24 October 2022

Available online 9 November 2022

Keywords:

Peer-to-peer energy trading

Pay-as-bid

Network cost allocation

Network usage cost

Evaluation framework

ABSTRACT

In pay-as-bid peer-to-peer (P2P) energy trading, various types of prosumers and consumers can participate, regardless of their offers. Thus, various types of participants impact the network differently. However, very few pay-as-bid P2P energy trading studies have specifically discussed appropriate compensation for network usage, although the market is implemented in existing utility-owned grids. Therefore, to improve the performance of pay-as-bid P2P energy trading, it is important to determine the appropriate compensation to utilities for network usage. This study aims to obtain an appropriate network cost allocation method for pay-as-bid P2P energy trading. Hence, the authors present a review of pay-as-bid P2P market mechanisms and various network cost allocation (NCA) methods. Additionally, a comprehensive evaluation framework is proposed to determine the most appropriate NCA method for the pay-as-bid P2P energy trading system. A comparison was made between various NCA methods to investigate the outcomes of the implementation of different NCA methods to various market conditions. The study constructs a case study based on the operator-oriented P2P model to represent the pay-as-bid P2P energy trading system. The simulation of pay-as-bid P2P energy trading with large participant number is applied in the IEEE 69-bus distribution system. The study concluded that applying the appropriate NCA method would improve the performance of pay-as-bid P2P energy trading operation.

© 2022 The Author(s). Published by Elsevier Ltd. This is an open access article under the CC BY-NC-ND license (<http://creativecommons.org/licenses/by-nc-nd/4.0/>).

1. Introduction

In recent years, there has been increasing interest in the integration of distributed renewable energy. However, the high penetration level of distributed renewable energy resources causes coordination issues in the distribution network, due to the natural characteristic of intermittency of renewable energy (Brandstätt et al., 2012). To solve this problem, the study in Pena-Bello et al. (2021) suggests that the participation of a distribution network's customers can be established through direct transactions. In addition, recent evidence, observed in Directive (2008), shows that most distribution systems' customers prefer direct transactions for them to assume full control. Therefore, the peer-to-peer (P2P) energy trading market is a solution that offers direct transactions between a distribution system's customers—prosumers as sellers and consumers as buyers (Tushar et al., 2020).

The number of P2P energy trading studies has grown rapidly in recent years, due to the advances in communication technology

that have been implemented in power systems. Thus, various methods have been applied to improve the performance of P2P energy trading, including blockchain technology (Esmat et al., 2021), non-cooperative game theory (Jing et al., 2020a), and optimization-based matching (Paudel and Gooi, 2019). Generally, the various developments can be categorized based on how they determine the market price as the principal aspect of P2P energy trading in a local electricity market: uniform and pay-as-bid pricing mechanisms (Benetti and Sperandio, 2020a). In a uniform pricing mechanism, there is only one market-clearing price, which is determined based on the equilibrium between supply and demand curves (Xu et al., 2021). Study in Tushar et al. (2016) constructs a uniform price auction-based energy storage allocation through P2P energy trading concept. From the study, the uniform pricing allows the lowest market-clearing price results; however, only customers with compatible payment can participate in the market.

Therefore, the pay-as-bid pricing scheme was developed for use when different types of customers traded at different prices, and is implemented by a third party or operator to allocate the resources (Wittwer, 2018). Therefore, the scheme allows more

* Correspondence to: Power System Laboratory, Energy Center 210, Ajou University, Worldcup-ro 206, Yeongtong-gu, Suwon, South Korea.
E-mail address: jjung@ajou.ac.kr (Jung J.).

List of abbreviations

BRP	Block Rate Pricing
DERS	Distributed Energy Resources
EBE	Distributed Generation
FERC	Federal Energy Regulatory Commission
LCOE	Levelized Cost of Energy
LP	Linear Programming
MILP	Multi-Integer Linear Programming
NCA	Network Cost Allocation
NUC	Network Usage Cost
P2P	Peer-to-Peer
PV	Photovoltaic
SMP	System Marginal Price
TOU	Time of Use

customers to participate in the P2P energy trading, thus creating additional benefits for the system. To perform a market transaction, the operators select which prosumers and consumers can participate, based on the offered energy prices. However, the energy prices offered by the participants are only determined based on their generation cost and willingness to pay. Because the P2P energy trading is conducted in an existing utility-owned network, the operators should also consider compensation for the network usage and, accordingly, determine the optimal matched-participants compensation method for network usage resulting from the P2P energy trading, especially for those using the pay-as-bid pricing mechanism.

Technically, compensation for network usage cost (NUC), including the cost of maintenance, planning, and operation of the power system infrastructure, is the responsibility of the generators and loads. Therefore, a possible solution to this problem is to distribute the NUC among all market participants (Tushar et al., 2021). The term, network cost allocation (NCA), refers to a method of distributing NUC. An NCA method ensures the quality of transmission service by satisfying a set of restrictions (Benetti and Sperandio, 2020b). Thus, NCA methods offer various benefits, including preventing cross-subsidies between network users, providing adequate remuneration for present and future transmission investments, communicating economic signaling for future dimensioning, and allowing continuity of existing network charges (Fink et al., 2011). Furthermore, applying the NCA methods can be one of the ways to manage network congestion, which according to Tushar et al. (2018) and Tushar et al. (2019), is becoming a challenge due to the increasing number of users in P2P energy trading.

Generally, NCA methods can be categorized into two types, based on the use of power flow results: non-power flow-based and power flow-based method. The basic concept of non-power flow-based methods include the postage stamp, contract path, and MW-mile methods, is to distribute the NUC based on the transacted power magnitude, without considering the actual network conditions (Shahidehpour et al., 2003). Although these methods provide straightforward calculations, they fail to specify individual contributions because they allocate average NUC based on the assumption that all network facilities are used (Happ, 1994). Therefore, power flow-based methods, such as Bialek's tracing, Kirschen's tracing, the equivalent bilateral exchange (EBE), and the Z-Bus NCA methods, were developed to determine specific participants' contributions (Lima et al., 2009a). By allocating the NUC based on the specific contribution of each generator or load, the degree of cross-subsidies can be reduced (Nikoukar and Haghifam, 2012). However, in contrast to the non-power

flow-based methods, the power flow-based methods entail more complicated calculations.

In addition, the application of the existing NCA methods has been limited to centralized power system operation; few studies have considered the feasibility of implementing the NCA methods in decentralized power system operation, especially pay-as-bid P2P energy trading. In this market model, multiple pairs of prosumers and consumers are determined dynamically according to their bidding process. However, due to the dynamic transactions in pay-as-bid P2P energy trading, the power flows can become complex, with counter flows and fluctuating transacted capacities, which can cause grid issues, such as voltage variations and congestions (Azim et al., 2020a). To date, no study has focused on the implementation of NCA methods in pay-as-bid P2P energy trading (the trading that allows more active interactions between prosumers and consumers). Therefore, there is an urgent need to determine the most appropriate NCA method to implement in pay-as-bid P2P energy trading through the comprehensive investigation framework.

The objective of this study is to investigate the suitability of the existing NCA methods for pay-as-bid P2P energy trading. For this, the case study of the operator-oriented model is used to represent pay-as-bid P2P energy trading. Market with large participants is simulated in the IEEE 69-bus system, whose results are analyzed to determine the most appropriate NCA methods for P2P energy trading. In summary, the main contributions of this paper are as follows:

- (1) The pay-as-bid P2P energy trading and developed NCA methods are reviewed to give comprehensive understandings about the field.
- (2) Requirement diagram analysis is employed to determine the principal parameters, that can influence the performance of pay-as-bid P2P energy trading.
- (3) The framework of evaluation is constructed by various scenarios to explore the ability of each NCA method in different market conditions.
- (4) The simulation integrates various type of electricity customers including residential, commercial, and industrial with actual generation and load pattern, which can make the evaluation results more valuable in formulating pay-as-bid P2P market strategies.

The remainder of this paper is structured as follows. Advanced research in P2P energy trading is discussed in Section 2, while Section 3 presents a description of the various NCA methods and the proposed evaluation framework. Finally, the results for each method under various evaluation scenarios are presented and discussed in Section 4. Section 5 concludes, with suggestions for future research.

2. Pay-as-bid P2P energy trading

The concept of pay-as-bid is borrowed from the financial sector, in which it is used to allocate large classes of assets and commodities. The application of the pay-as-bid scheme in P2P energy trading has been proposed in both academic studies and practical projects. In addition, as an auction mechanism, the important aspects of the pay-as-bid scheme are the pricing adjustment and selection process. Therefore, to provide a complete picture, the concept of the pay-as-bid P2P energy trading mechanism is elaborated under three subsections: general description, pricing adjustment, and selection process.

2.1. General description

In this pricing scheme, market participants bid their supply and demand at different quantities and prices (Lin et al., 2019). This method was developed as an extension to the well-known uniform pricing of auction goods, which has a high degree of product fragmentation (Oren, 2004). In the symmetric equilibrium of a pay-as-bid auction with symmetrically informed bidders, each bidder submits their bid for one among all shares as if they competed with all the bidders for one indivisible good in a first-price auction with independent private values (Wittwer, 2020). This means that the pay-as-bid pricing mechanism encourages a highly competitive environment for maximum benefit from auctions. Thus, regarding power systems, the pay-as-bid mechanism is commonly used in the trading of the power commodity, which has high uncertainty and multiple traded units.

As a reference, the pay-as-bid pricing mechanism has been used in the electricity markets in Germany and Italy (Wang et al., 2015). In these countries, the pay-as-bid mechanism has been used to balance the markets, including spinning and non-spinning reserves. Iran and England use pay-as-bid as a major trading mechanism for their electricity markets (Motamedi et al., 2014; Stacke and Cuervo, 2008). They use a discriminatory pricing method to determine the electricity price based on the estimated marginal cost. Furthermore, due to the massive transition in power systems from natural monopolies towards competitive markets, pay-as-bid pricing is considered in many studies of the electricity market. In Swider and Weber (2007) and Swider (2007), the pay-as-bid approach was adopted for simultaneous bidding in pay-ahead auctions for spot energy and power systems reserves. For non-spinning reserves, day-ahead bidding was implied in the P2P energy trading with renewable energy resources (Meinke et al., 2020). Additionally, the pay-as-bid pricing scheme has been used ubiquitously in various P2P energy trading research, such as in discriminatory k-double auctions (Angaphi-watchawal et al., 2021), community-based microgrids (Vieira and Zhang, 2021a), and bilateral-contract P2P (Morstyn et al., 2018).

Generally, pay-as-bid P2P energy trading has two important aspects: price-adjustment and selection process. As the figure shows, in the price-adjustment step, the participants submit their bids, including trading prices and capacities. Furthermore, the selection process starts with a double auction mechanism to optimize the objective function accordingly. Finally, settlement by the operator allocates the payment and energy to each participant, as they bid. The details of each pay-as-bid P2P energy trading aspect are elaborated on as follows.

2.2. Price-adjustment process

As an electricity market mechanism, it is important for a pay-as-bid P2P energy trading system to confirm its price calculation in the initial step of the price-adjustment process. As already mentioned, at a minimum, the selling and buying prices are confirmed before a transaction occurs. Determining the selling and buying prices is not straightforward. The bid prices should represent the actual sellers' and buyers' values, while the generation cost of renewable resources is considered zero, and not all customers understand their marginal willingness to pay. For this, the work in An et al. (2020) determines the transaction price based on each customer's electricity tariff with respect to their consumption level. As another reference, the trading prices can also be determined by calculating the levelized cost of energy (LCOE) for the energy price and the Ethereum blockchain costs for the platform cost, as in Vieira and Zhang (2021b).

Given that pay-as-bid P2P energy trading is performed by an operator, additional charges are required to maintain the market operation. The study in Heo et al. (2021) uses at least two

additional costs to ensure market operation: a market platform service charge and an NUC. A market platform service charge is defined as an operator's compensation for maintaining platform and administration services. Details on how to determine the market platform service charge are beyond the scope of this study. Usually, an NUC is not considered if a transaction is performed in a distribution network. The NUC can be included in pay-as-bid P2P trading as a weighting factor in the form of a ratio (Paudel et al., 2020). Other than being considered as a ratio, a few studies acknowledge the NUC as either a fixed rate or a volumetric rate (Brown and Faruqui, 2014).

2.3. Selection process

Following the price-adjustment process, the selection process commences. In this phase, each market participant's trading price will be evaluated to decide whether the prosumers and consumers are eligible to continue their participation in the pay-as-bid P2P energy trading. Thus, if they can obtain benefit from the market transactions, the energy resources and profit will be allocated by the operators automatically. For this, there are two optimization methods commonly used for pay-as-bid P2P energy trading: linear programming (LP) (Mazzi et al., 2017) and multi-integer linear programming (MILP) (Guerrero et al., 2018; Jing et al., 2020b). Using an optimization method, the operator constructs an offering strategy or matching schedule for the prosumers and other market participants. The scheduling strategy is constructed by reference to several elements: the bid selling and buying prices, the platform costs, the NUCs or network loss compensations, and the available transacted capacities from both the prosumers and the consumers.

Generally, the optimization method will work as follows: When trading in a pay-as-bid P2P energy trading market, prosumers can only submit their selling price and expected generation offers, while consumers submit their buying prices and consumption capacities. In the initial bidding stage, both prosumers and consumers can manually withdraw from the auction if they find that the offered price is not beneficial to them. Then, the operator will compute and determine the optimal market offer and possible pairing schedule. The selection process is performed iteratively and continuously, as long as there is a possibility of a higher profit in other pairing combinations. Finally, the selection process is stopped when the optimum profit has been reached. For this, iteratively, the operator should consider whether they have found the optimum profit, not only for the market participants, but also for themselves, which requires the least operation cost.

Fig. 1 presents the pay-as-bid P2P energy trading mechanism framework. In the figure, the operator determines the amount of transaction capacity and energy trading price for the prosumers and consumers. In addition, by implementing NCA method, the NUC will eventually affect the energy trading price as shown in the graph at settlement stage. In this case, the appropriate NCA methods for pay-as-bid P2P among Postage Stamp, MW Mile, Bialek tracing, Kirschen tracing, EBE, and Z-bus NCA should be selected. For this, the NCA methods and evaluation scenarios will be explained further in the following sections".

3. NCA methodology

Network cost is currently the main method of compensating a distribution network for electricity transmission to consumers. In a conventional power system operation, the network cost is considered as fixed; thus, the consumers can pay it as a proportion of their electricity bill. In 2016, households' network costs

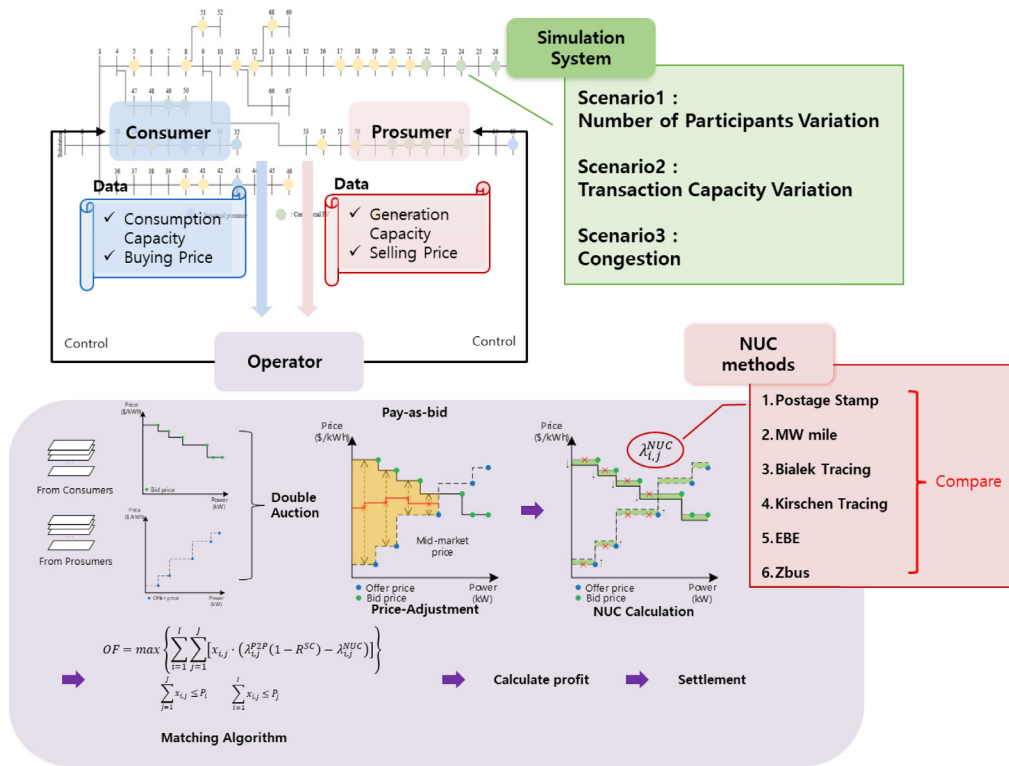

Fig. 1. Pay-as-bid P2P energy trading mechanism framework.

in European countries represented, on average, 27% of their electricity bills (Schittekatte and Meeus, 2018). Furthermore, for the photovoltaic (PV) generation owners or prosumers, the network cost is defined as a fixed volumetric cost, which is calculated based on the net-metered generation capacity for a certain period (e.g., monthly). However, these network costs, which were designed for passive power systems, can no longer serve their purpose in active ones.

To solve this problem, the NCA methods were studied to distribute different NUCs among electricity customers. Each NCA method required both upstream-looking and downstream-looking algorithms to calculate prosumers' and consumers' NUCs, respectively. Additionally, according to the basis of allocation in the cost computation, the various NCA methods can be categorized into two types: non-power flow-based and power flow-based. By incorporating power flow analysis results into account, the latter type is enabled to consider physical constraint. However, the non-power flow-based NCA methods may not be aware of any physical limitation of the network. Further, the two types are discussed in detail in the following subsections.

3.1. Non-power flow-based NCA method

3.1.1. Postage stamp

The postage stamp method allocates the NUC based on the power injected by each generator and consumed by each demand. According to (Pan et al., 2000), the postage stamp method is independent of the transmission distance, supply, and delivery point (or the loading on different transmission facilities) associated with a transaction. In this method, the total network usage is defined as the summation of the network usages of all the lines. The network usage of a line is obtained from the total power generation and consumption of each generator and load, respectively, in each line.

In the postage stamp method, the upstream-looking and downstream-looking algorithms to allocate the NUC are constructed in similar equations. For this, initially, the line usage due to each prosumer and consumer is calculated using the following formula:

$$U_l^i = \sum_{i=1}^I \left(\frac{P_i}{\sum_{i=1}^n P_i} \right) \times U_l, \tag{1}$$

where U_l^i is the usage of Line l due to either the prosumer or consumer in Bus i . P_i represents the energy capacity of either the prosumer or consumer in Bus i . Furthermore, the total NUC allocated to each customer is calculated according to the usage (U_l^i) and the rate cost (r_l) of Line l . Thus, the total NUC allocated to each customer can be calculated as follows:

$$C_l^i = r_l \cdot U_l^i \tag{2}$$

$$NUC_i = \sum_{l=1}^L C_l^i, \tag{3}$$

C_l^i is the NUC of Line l due to the usage of a customer at Bus i , while NUC_i represents the total NUC allocated to each customer at Bus i . According to the formulas above, all customers connected to the grid are obliged to pay for the network usage of the entire system. In this case, the main drawback of this method is the cross subsidies between customers; thus, it is difficult to distribute the NUC fairly using this method. On the one hand, the advantages of this method are the simple calculation and straightforward NUC results.

3.1.2. Contract path

Contract path is an NCA method whereby the customer agrees on a fictitious path for the transmission service (Krause, 2003). As with the postage stamp method, this method requires no power

flow calculation to allocate the NUC. In the method, a contract path interconnects the points of injection and receipt, although it is defined without power flow studies. The contract path is determined with all, or a part of the transmission costs related to the specified path assigned to the transaction. For this, the network operator must know all the concluded contracts between the producer and the consumer, to determine if there is additional usage in the single transactions.

Specifically, the contract path is determined as follows. Under the contract path methodology, a specific path is chosen for an individual transmission transaction between two nodes. The contract path does not consider the actual power-flow lines that would occur. Eventually, it assumes that the tracks between the two nodes are constructed by several substations, regardless of the branches (Cannella et al., 1996). After the contracted paths are decided, the total transmission cost is calculated as the accumulation of the network usage of each possible traveled path. A share of the asset costs, including the costs of new investment, along the contract path is allocated to the wheeling customer in proportion to their use. In the contract path method, the NUC allocated to each customer is determined as

$$NUC_i = \left(\sum_{l=1}^L T_l \right) * \frac{P_i}{\sum_i P_i}, \tag{4}$$

where T_l is the transmission cost of the contracted path, l . The contract path method is straightforward and has been used by utility companies for a long time. It allows full cost recovery, as long as all asset costs along the contract path are considered, while it is easy to implement, with a stable pricing regime. However, similarly to the postage stamp, the methodology ignores the actual operation of a system and any congestion issues. An energy transaction will affect all the assets on a transmission system, and not only those along the contract path. As pointed out by Federal Energy Regulatory Commission (FERC), due to the laws of physics, it is unlikely that the actual power flow will follow the contract path (Hogan, 2019).

3.1.3. MW-mile

The MW-mile approach is an embedded cost method that considers the changes in the MW of transmission-flow capacity and transmission lengths in miles (Shirmohammadi et al., 1991). This method has inspired the transformation of the operation of power system markets, especially in defining a cost allocation method that ensures fair charges between generators or loads within a network (Shirmohammadi et al., 1989). A full recovery of fixed transmission costs that reasonably reflects the actual usage of a transmission system are guaranteed by this method. Thus, this method allocates the NUC based on the usage of firm transmission services by wheeling transactions.

The MW-mile method is also known as a line-by-line method because it considers both transacted capacity changes and the length of the transmission line in miles. In a non-power flow MW-mile method, the contribution is calculated by considering the length of the power line. If the length of the power line is unknown, the NUC can be calculated using the formula

$$NUC_i = TC \cdot \frac{\sum_{l=1}^L ur_l \cdot \Gamma_l \cdot P_i}{\sum_i \sum_l ur_l \cdot \Gamma_l \cdot P_i}, \tag{5}$$

where Γ_l represents the length of Line l , while ur_l is the rate cost per MW per unit length of Line l . Despite the inability of this method to count network constraints, it has improved the technical quality of the transmission service, especially in maintaining easy regulation, continuity of charge, and economic signals for dimensioning. The MW-mile method can also be used to calculate the transmission cost due to the transacted reactive

power, which is commonly known as the extended version of the MW-mile, or MVA-mile method. However, this method is difficult to apply in the operation of modern power systems, owing to the high penetration level of the distributed energy resources (DERs) integrated into grids. This is because the method does not consider the counter flow, which may occur when there is energy supply from distributed generators.

3.2. Power flow-based NCA method

3.2.1. Bialek tracing method

Bialek’s tracing method allocates NUC based on the proportion of inflows among nodal outflows (Bialek and Ziemianek, 2003). To calculate the proportion of inflows, this method uses a topological approach that represents how power flows in a network. In this method, upstream-looking and downstream-looking algorithms analyze how NUC is allocated to individual generators and loads, respectively. The contribution of each generator towards each load, and vice versa, can be calculated using this method.

The upstream-looking and downstream-looking methods are calculated separately, although they use a similar algorithm. In this study, the explanation of Bialek’s tracing method focuses on the upstream-looking algorithm. In Bialek’s tracing method, the main key to allocating NUC is to find a representation of the topological distribution factors, which are represented by the upstream distribution matrix. The upstream distribution matrix represents the ratio between the absolute power flow towards Bus i from Bus j ($|P_{j,i}|$) and the total power injected to Bus i (P_i), which can be written as follows:

$$[A_u]_{j,i} = \begin{cases} 1 & ; \quad i = j \\ -\frac{|P_{j,i}|}{P_i} & ; \quad j \in \beta_i^u \\ 0 & ; \quad otherwise \end{cases}, \tag{6}$$

where $[A_u]_{ji}$ stands for upstream distribution matrix, while β_i^u is the set of buses that supply Bus i . Then, the NUC allocated to each generator is determined by accumulating the generator’s contributions to all the line flows, which can be formulated as follows:

$$NUC_i = P_i \cdot \sum_{j=1}^J \left(\frac{[A_u^{-1}]_{j,i}}{P_j} \cdot r_{j,i} \right). \tag{7}$$

Based on the explanation above, this method has advantages over the methods discussed before. This method can be used to calculate both AC and DC power flow because it only considers the absolute value of the power flow; thus, it can also be used to calculate the counter flows (Bialek and Kattuman, 2004). However, because it only considers absolute values, it cannot distinguish the contribution from the counter flow to a grid. Furthermore, Lima et al. (2009b) show that the resulting NUC from this method are highly volatile.

3.2.2. Kirschen tracing method

Kirschen’s tracing method determines individual generators’ contributions in supplying a load, based on the domain and common concepts (Strbac et al., 1998). A domain refers to a set of buses that are supplied by the same generator according to the direction of power flow. To help identify the contribution of buses that are supplied by multiple generators, the common concept is used to classify contagious buses that are supplied by the same generator. In this method, the commons are ranked; thus, their connections to each other correspond to the direction of power flow. Consequently, an equivalent network is constructed to represent the actual grid.

The equivalent network is then used in calculating each generator's contributions. Two contributions are considered to calculate the NUC: the absolute and relative contributions. The absolute contribution is the total flow injected to Common n owing to Generator i ($A_{i,n}$). The relative contribution ($R_{i,n}$) is defined as the ratio between $A_{i,n}$ and the sum of flows at the link to Common s . Initially, the flows at the link from Common m to Common n ($F_{m,n}$) are calculated as the sum of the injected power flows to Common n , and are calculated from a power flow analysis. Then, the absolute and relative contributions are calculated from the highest-rank to the lowest-rank commons, using the formula

$$A_{i,n} = \sum_m^M R_{i,m} \cdot F_{m,n} \quad (8)$$

$$R_{i,n} = \frac{A_{i,n}}{\sum_m^M F_{m,n}}. \quad (9)$$

The absolute and relative contributions are then calculated; Generator i 's NUC to the power flow in Line l ($NUC_{i,l}$) is calculated using the formula

$$NUC_i = \sum_l^L \left(\frac{R_{i,n} \cdot F_l}{\sum_i^L \sum_i^L R_{i,n} \cdot F_l} \right) \cdot TC, \quad (10)$$

where, F_l is the power flow at Line l . Despite Bialek's concerns (Kirschen et al., 1997) that Kirschen's tracing method yields no unique results, due to the minimum mathematical evidence, this method offers some advantages, such as unlimited to incremental changes in injections, and not requiring complex calculation, such as linearizing the network model; furthermore, it can allocate different NUCs to customers located in different locations.

3.2.3. Equivalent bilateral exchange

The principle of EBE for a single-area power system is enunciated and justified as an alternative flow-based NCA approach that avoids some of the disadvantages of the other methods (Galiana et al., 2003). The EBE method allocates NUC to the generators, while demands are based on the distribution factors. The distribution factors are used to determine the approximate impact of each generator and load on the network. The distribution factor is calculated using the formula

$$GD_{i,j} = \frac{P_i \cdot P_j}{\sum_j^J P_j}, \quad (11)$$

where, $GD_{i,j}$ is the distribution factor owing to the supply from Generator i to Load j . The EBE method uses actual power flow, which is represented as the line flow distribution factor due the supply from the generator at Bus i to the load at Bus j through Line l ($\gamma_{i,j,l}$), as follows:

$$\gamma_{i,j,l} = h_l^T \cdot \delta_{i,j} \quad (12)$$

where h_l^T stands for the conductance matrix, while $\delta_{i,j}$ is the phase-angles vector between Buses i and j . The EBE method allocates NUC using the distribution factor based on both the generator and load ratio and the power flow supplied from the generator to the load. In the upstream-looking algorithm, the NUC allocated to the generator is formulated as follows:

$$NUC_i = \frac{1}{2} \cdot \frac{\sum_l^L C_l \cdot |\gamma_{i,j,l}| \cdot GD_{i,j}}{\sum_i^L \sum_j^J |\gamma_{i,j,l}| \cdot GD_{i,j}} \quad (13)$$

Based on the elaboration above, this method allocates NUC by considering the contribution of each generator and load owing to both generation or consumption capacity and the actual condition

of the network. Additionally, the results in Zia et al. (2020) show that the EBE method is capable of presenting relatively stable NUC without neglecting counter flows. However, this method ignores the customers' physical distance, although it considers the electrical distance that is represented in the conductance matrix.

3.2.4. Z-bus NCA method

The Z-Bus NCA method considers a network's physical parameters in allocating the contribution of generators or loads for NUC calculation. The Z-bus method calculates the contributions of nodal currents to line-power flow with respect to the use of lines (Pouyafar et al., 2019). The contributions of generators and loads are calculated based on the voltage and current of a node based on its complex power flow. To calculate the NUC, initially, the physical network parameter is calculated as follows:

$$a_{i,j}^l = (z_{j,l} - z_{i,l}) y_{i \rightarrow j} + z_{i,j} y_{i \rightarrow j}^{sh} \quad (14)$$

where $a_{i,j}^l$ represents the physical network parameter between Buses i and j through Line l . $z_{j,l}$ and $z_{i,l}$ are the impedances of Line l with respect to Buses j and i , respectively. $y_{i \rightarrow j}$ and $y_{i \rightarrow j}^{sh}$ are the admittance and shunt admittance between Bus i and Bus j , respectively. The parameter, $a_{i,j}^l$, measures the electrical distance from Bus i to Line l . Furthermore, in the upstream-looking algorithm, each generator's contribution is determined based on the current in a complex form that can be obtained from the power-flow calculation. The power flow through Line l due to the transaction between Generator i and Load j , and each generator's contribution are calculated using the following formulas:

$$P_{i,j}^l = |\Re\{V_j a_{i,j}^{l*} I_i^*\}| \quad (15)$$

$$U_i^l = \frac{|P_{i,j}^l| + |P_{j,i}^l|}{2} \quad (16)$$

where, U_i^l represents Generator i 's contribution to the power flows in Line l . V_j is the voltage at Bus j , which is obtained from the power-flow result. $a_{i,j}^{l*}$ and I_i^* are the conjugative form of $a_{i,j}^l$ and current flows through Line l , respectively. After each generator's contribution has been determined, the NUC is calculated using the following formula:

$$NUC_i = \sum_{l=1}^L C_l \cdot U_i^l \quad (17)$$

Based on the explanation above, this method can be assumed to be a physical-based method. Hence, the main disadvantage of this method is experienced by independent operators, because the grid specification data is considered confidential. Furthermore, according (Conejo et al., 2007), the NUCs allocated between generators and loads are not equally distributed. However, this method calculates NUC regardless of slack buses, accommodates counter flows, and has relatively low volatility in allocating NUC among buses (Lima et al., 2009b).

3.3. Evaluation framework

In this subsection, an evaluation framework for the NCA methods in the pay-as-bid P2P energy trading market operation is proposed. The evaluation framework is constructed by considering the elements and transaction mechanism of P2P energy trading. Initially, the pay-as-bid P2P energy trading mechanism was performed based on two elements: participant and trading capacity. However, the network limitation should be considered also into the transaction mechanism to obtain optimal P2P energy trading results by maintaining network's reliability. Hence,

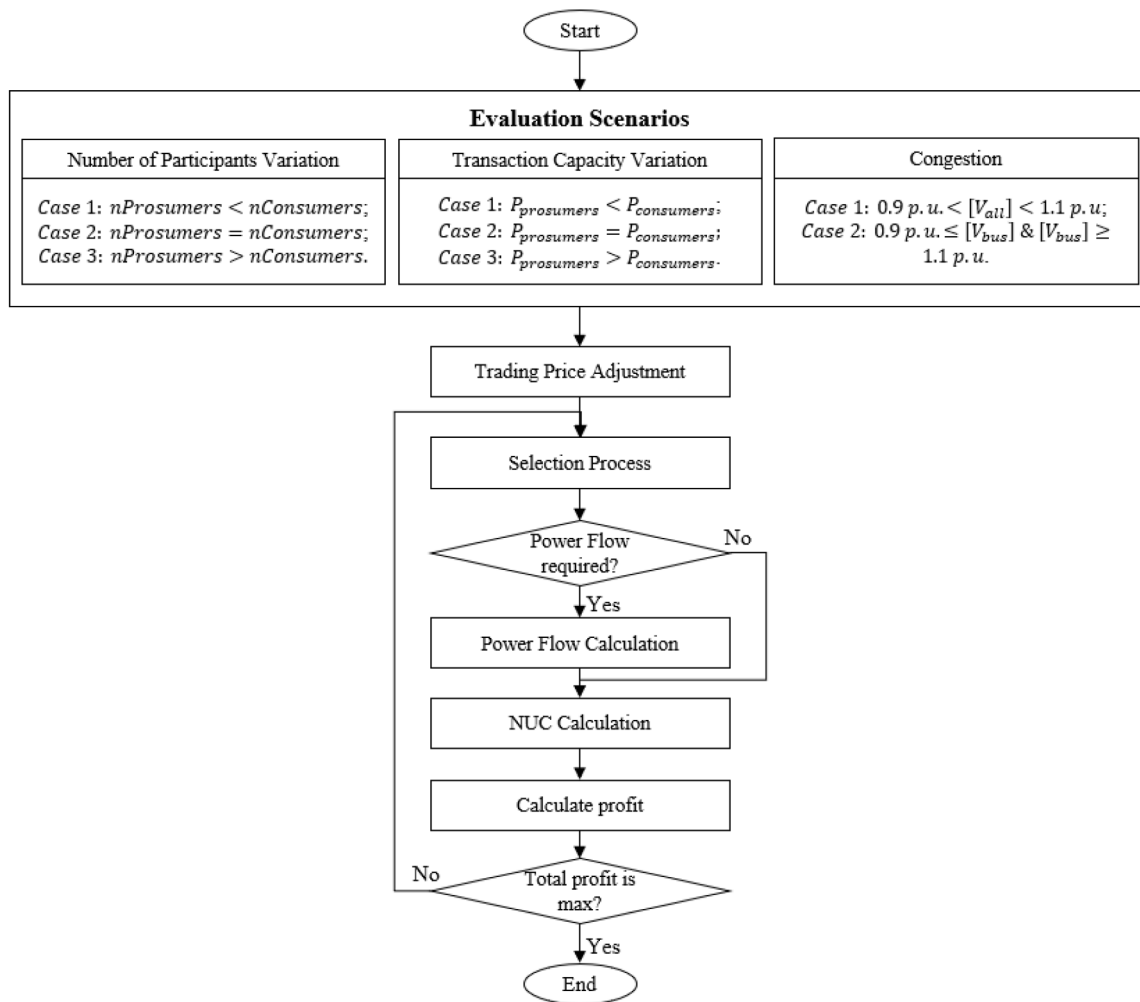

Fig. 2. Evaluation framework flowchart.

the network congestion status should be considered, and thus affecting the pay-as-bid P2P energy trading results to reduce the congestion risk. Therefore, the evaluating scenarios for NCA method should be able to emphasize the characteristics of each method with respect to three aspects: the number of participants, generation capacity from renewables, and network congestion.

These aspects are discussed under the following considerations. According to (Azim et al., 2020b), when many customers participate in a P2P energy trading network, it may lead to voltage nodes and additional losses in the distribution system. Therefore, when determining network costs, these conditions, which threaten the sustainability of a network's operations, should be considered. In addition to the number of participants, the available transacted capacity has a major impact on the results of the selection process in determining NUC. Against this background, high renewable generation has been found to be allocated with higher NUC, unless it is located close to heavy loads (Noorfatima et al., 2021). Furthermore, the benefit of the P2P energy trading application in the distribution network cannot be improved unless compensation for network utilization is considered. For example, high-generation prosumers tend to induce high congestion risk, which may cause additional charges in recovering the network condition (Sioshansi, 2019).

Fig. 2 shows the flowchart of the evaluation framework, with three sets of scenarios; only one scenario can be evaluated at a time. As explained in Section 2, pay-as-bid P2P energy trading comprises two main operations: price adjustment and the

selection process. According to the flowchart, price adjustment focuses on determining the trading price based on the three scenarios. Having adjusted the trading price, the selection process commences. Initially, the selection process does not consider the NUC. However, after the pairs of prosumers and consumers have been selected, the NUC is calculated using all the NCA methods. If an NCA method requires a power-flow calculation, then the calculation is performed based on the results of the selection process. Having calculated the NUC, all the participants' profit is accumulated, and evaluated using the optimization method, to determine whether it is maximum. If the solution is not feasible, then the selection process is repeated by reference to the NUC results from the previous iteration.

4. Simulation: Evaluating P2P energy trading with various NCA methods

In this section, the P2P energy trading with different NCA methods is simulated under the IEEE 69-bus distribution test system (Das, 2008). Thus, the proposed evaluation framework is performed to determine which NCA method is the most compatible with the P2P energy trading market operation.

4.1. Operator-oriented P2P energy trading

In the operator-oriented P2P model, the market participants conduct transactions and share mutual profits through the trading platform (Heo et al., 2021). The objective of this model is to

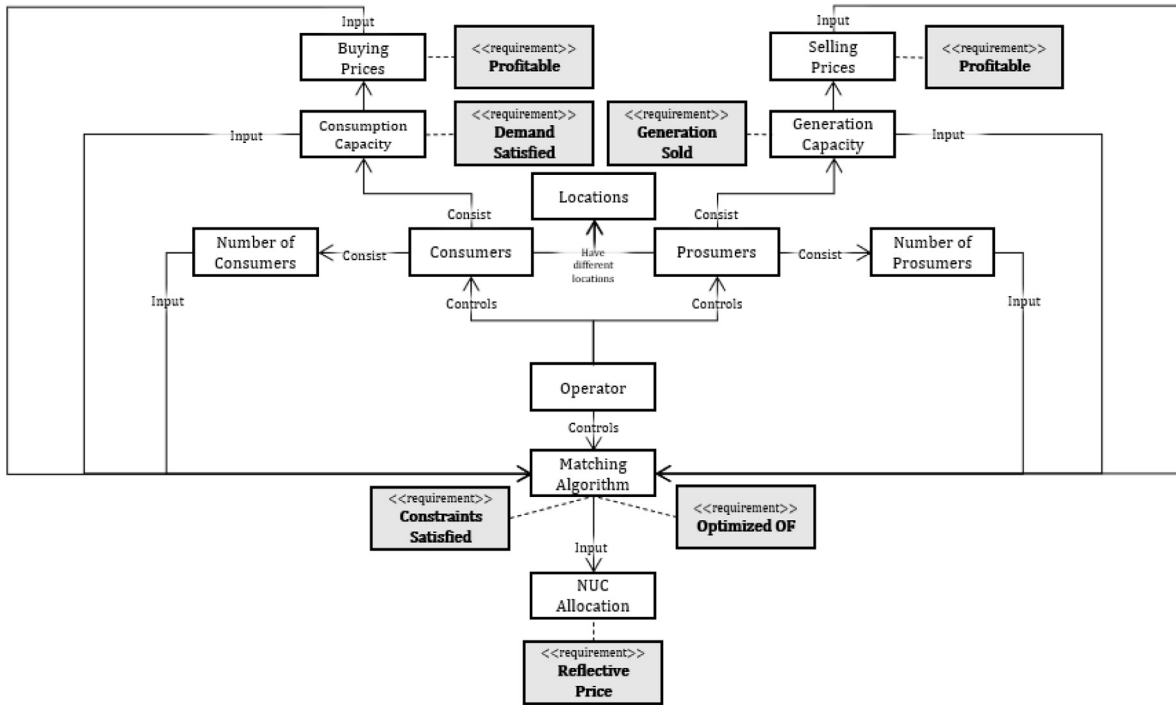

Fig. 3. Requirement diagram of the operator-oriented P2P model.

encourage distribution network customers to actively participate in P2P energy trading by providing simple trading procedures. For the pay-as-bid P2P energy trading, the operator-oriented P2P model is based on two main procedures: price-adjustment and the selection process. The operator-oriented P2P model mechanism is presented in more detail in the requirement diagram in Fig. 3.

In the pay-as-bid P2P energy trading, the operator-oriented P2P model determines both the prosumers' and the consumers' trading prices. According to the requirement diagram, the bidding prices of prosumers' and consumers' bidding prices are derived from the electricity prices (λ^{Elec}), which are the function of the generation capacity and consumption capacity, respectively. Having determined the bidding prices, the trading price is formulated as the mid-price, which is written as follows:

$$\lambda_{i,j}^{P2P} = \frac{\lambda_i^{Bid} + \lambda_j^{Bid}}{2} \quad (18)$$

where $\lambda_{i,j}^{P2P}$ is the P2P trading price between prosumer i and consumer j . λ_i^{Bid} and λ_j^{Bid} represent prosumer i 's and consumer j 's bidding prices, respectively. The trading price is determined by the operator beforehand, due to the absence of direct auction.

With the trading prices determined, the procedure continues to the selection process, the aim of which is to obtain maximum benefit for all the participants. For this, a matching algorithm is utilized by considering the NUC. The matching algorithm uses MILP to optimize the objective function and constraints, which are formulated as follows:

$$OF = \max \left\{ \sum_{i=1}^I \sum_{j=1}^J [x_{i,j} \cdot (\lambda_{i,j}^{P2P} (1 - R^{SC}) - \lambda_{i,j}^{NUC})] \right\} \quad (19)$$

$$\sum_{j=1}^J x_{i,j} \leq P_i \quad (20)$$

$$\sum_{i=1}^I x_{i,j} \leq P_j \quad (21)$$

where $x_{i,j}$ represents the selected trading capacity between prosumer i and consumer j . R^{SC} represents the service charge ratio, which is a platform usage fee determined by the market operator. In this model, the operator decides whether the customer is allowed to participate in the P2P market, based on the feasibility of gaining a profit. In addition, the operator considers the selected pairs based on the optimum NUC allocation.

4.2. Assumptions

The evaluation framework comprises three scenarios: the variation of the renewable penetration level, the variation of the number of participants, and the congestion condition. However, to provide some illustration of how the network configuration is constructed, a distribution network containing multiple prosumers with PV generation for the base-case P2P energy trading operation is presented in Fig. 4.

The original test system provided neither the time-varying load nor the prosumer generations; therefore, the simulations are performed using the hourly consumption data obtained from Lee et al. (2022). For diversity, different types of consumers and prosumers are applied, including industrial, commercial, and residential. Fig. 5 shows the normalized load patterns during a day, which are derived from the average load capacity of various types of consumers.

For a more realistic simulation, the South Korean case was chosen. The actual time-varying PV generation data for May 22, 2020, were obtained from PVWatts (PV Watts Calculator, 2021). Fig. 6 shows the normalized PV generation profiles. It shows that PV generation occurs from 6 am to 8 pm, with peak generation at 1 pm on a selected day.

Based on each type of electricity customer, the electricity price is calculated using the block rate pricing (BRP) and time of use (TOU) mechanism (International Electric Tariff, 2021). In addition, to determine the PV generation price, the South Korean hourly system marginal price (SMP) data for May 22, 2020 were used, as shown in Fig. 7 (System Marginal Price, 2021).

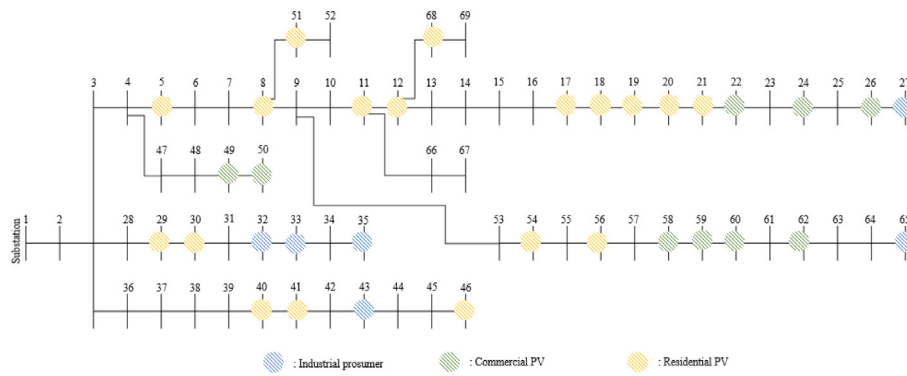

Fig. 4. Simulation test case in IEEE 69-bus distribution system.

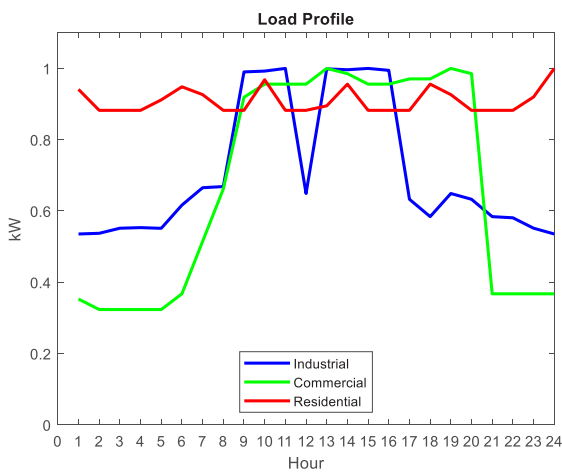

Fig. 5. Load profile of P2P participants in one day.

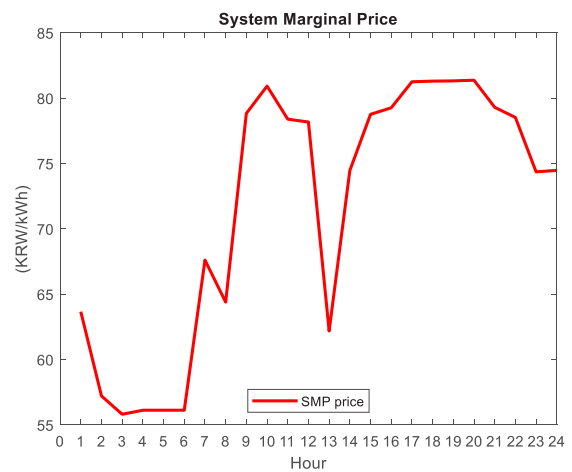

Fig. 7. SMP in a day.

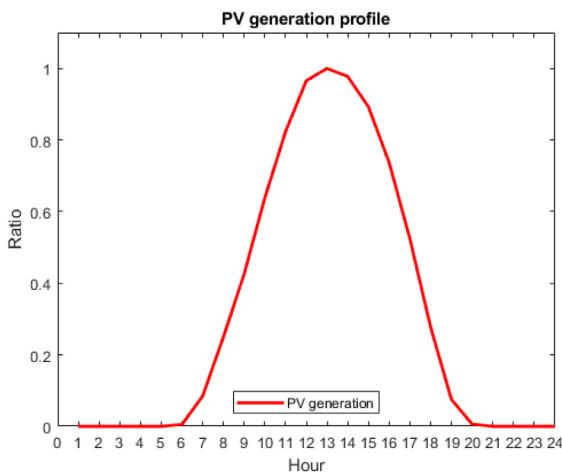

Fig. 6. Generation profile of various prosumer categories in one day.

4.3. Case study

In this subsection, P2P energy trading with selected NCA methods was simulated for the three evaluation scenarios: varying the number of participants, capacity variation, and congestion variation. The simulations were performed using the operator-oriented P2P energy trading model using different NCA methods. In the original operator-oriented P2P energy trading model, the pairs of prosumers and consumers are selected based on

a fixed network cost. For this, it is assumed that total compensation for network usage is based on a volumetric network tariff of 3.13 KRW/kWh (Network Usage Cost, 2021). However, the contract path method is excluded from the comparison this method's NUC allocation is rarely performed unless the actual path specifications are known.

4.3.1. Scenario 1: Variation of the number of participants

In this scenario, the number of participants is varied under three conditions: the number of consumers exceeds the number of prosumers, the number of consumers equals the number of prosumers, and the number of prosumers exceeds the number of consumers. For this, the total transaction capacity will be maintained constant in all the cases. These simulations aim to evaluate how each NCA method allocates the NUC in the different scenarios.

Fig. 8 shows the matched transactions and NUC unit resulting from each NCA method when the number of prosumers is less than the number of consumers. For the postage stamp method, as shown in Fig. 8(a), a constant NUC unit is obtained. For the MW-mile and Bialek's tracing methods, as shown in Fig. 8(b) and (c), respectively, the NUC is allocated to the participants according to the number of matched transactions. Different patterns are obtained for the Kirschen tracing, EBE, and Z-Bus NCA methods, as shown in Fig. 8(d)–(f), respectively. During the low PV-generation period, the NUC allocated is higher than during the other times during the transaction period. However, the Kirschen tracing and Z-Bus NCA methods allocate significantly lower NUC during higher PV generation.

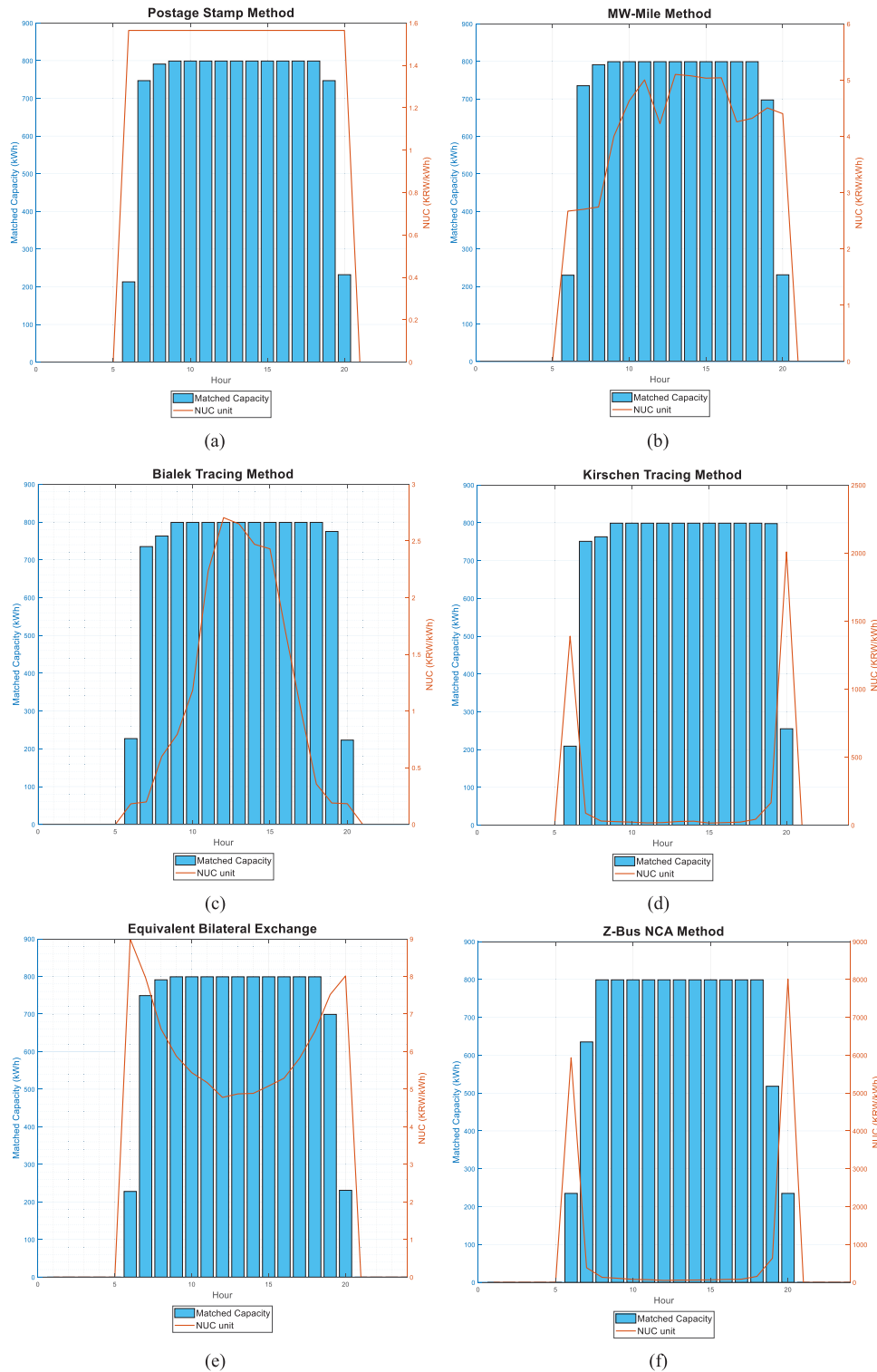

Fig. 8. Case 1: The number of consumers exceeds than the number of prosumers.

Fig. 9 presents the NUC and matched transaction results from all the NCA methods when the number of prosumers equals that of consumers. The postage stamp method produces similar results to the previous case, although the number of matched transactions is higher, as Fig. 9(a) shows. Regarding the MW-mile and Bialek’s tracing methods, shown in Fig. 9(b) and (c), respectively, the MW-mile method allocates lower NUC than the previous results, while Bialek’s tracing method allocates higher NUC, along with a higher number of prosumers. Furthermore, the

Kirschen tracing and Z-Bus NCA methods, as shown in Fig. 9(d) and (f), respectively, present a similar pattern, with higher NUC allocated to participants, along with higher matched capacities. In contrast, the EBE method allocates similar NUC amounts to those in the previous simulation, although the number of matched transactions is higher.

Fig. 10(a) shows that the NUC allocation by the postage stamp method remains unchanged, although the number of matched transactions decreases. In this case, the method allocates the NUC

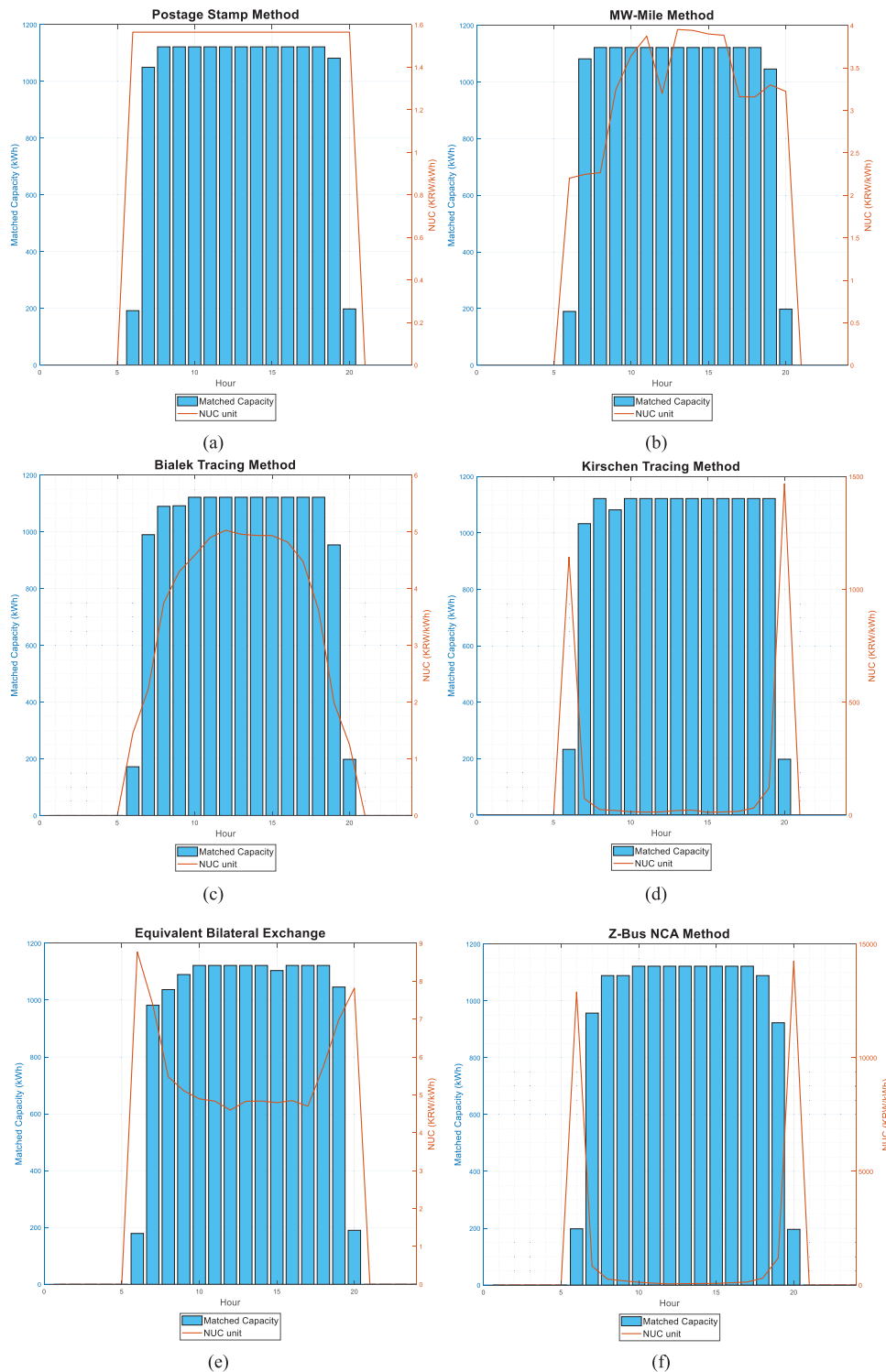

Fig. 9. Case 2: The number of prosumers equal to the number of consumers.

units equally among all the participants in the various market conditions. Although the MW-mile method is also categorized as a non-power flow method, the NUC unit that results from this method is different from that of the postage stamp method. As shown in Fig. 10(b), the NUC allocated to the P2P participants is reduced accordingly, while the number of matched transactions declines, due to the difference in the number of prosumers and consumers. Fig. 10(c) shows the results for Bialek’s tracing

method in allocating the NUC, contrasted with the number of matched transactions.

Different patterns are shown by the Kirschen, EBE, and Z-Bus NCA methods. Fig. 10(d) shows the NUC allocation using the Kirschen tracing method. The NUC unit allocation by the Kirschen method shows a contrasting pattern with the previous NCA methods. As seen in the graphs, the Kirschen method allocates a higher NUC unit when the number of matched transactions in the market rises. However, similar patterns are shown by EBE method,

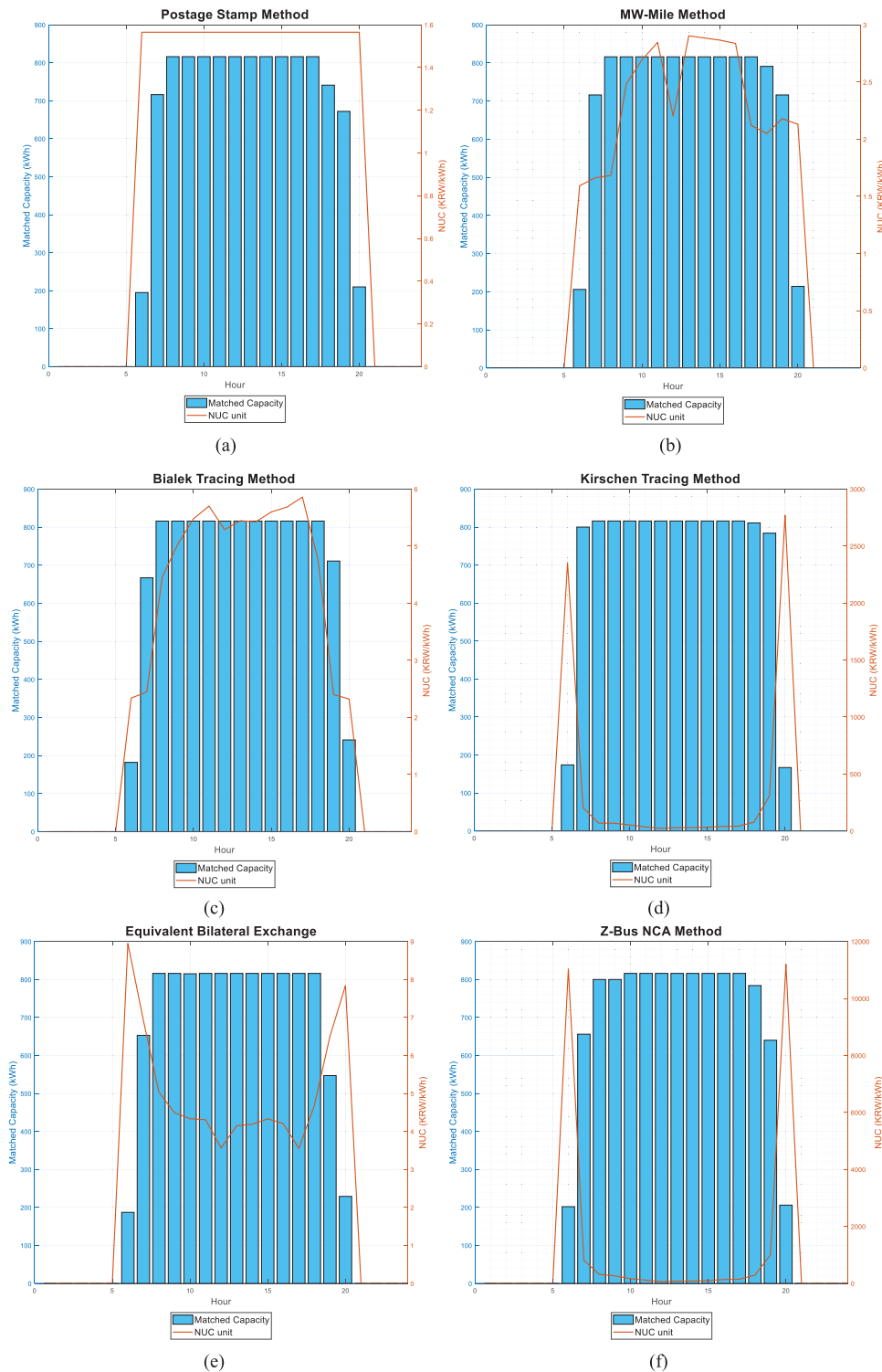

Fig. 10. Case 3: The number of prosumers exceeds the number of consumers.

as Fig. 10(e) shows. However, in the EBE method, the difference between the highest and lowest NUC unit allocated within a day is not drastic. In addition, the EBE method is capable of allocating relatively stable NUCs compared with the previous simulations results. The Z-Bus NCA method allocates the least NUC unit for the various scenarios with different numbers of participants, as Fig. 10(f) shows. Similarly, to the Kirschen method, the Z-Bus NCA method allocates a higher NUC during the period of the lowest matched transactions.

Table 1 contains minimum, maximum, and range in percentage of NUC allocated by all NCA methods in various variation of the number of participants scenarios. The range in percentage aims to show how significance the NUC may be distributed throughout the trading time. According to the table, Postage Stamp has the lowest range value, meanwhile Z-bus NCA method has the highest variability. Low range value can be interpreted as stable NUC allocation, and high range value means otherwise.

Table 1
Scenario 1: Variation of the number participants results comparison.

No.	Methods	Scenario 1: Variation of the number of participants								
		nPro > nCon			nPro = nCon			nPro < nCon		
		min	max	Range	min	max	Range	min	max	Range
1	Postage stamp	1.565	1.565	0.00%	1.565	1.565	0.00%	1.565	1.565	0.00%
2	MW mile	1.593	2.904	45.10%	1.198	2.090	42.70%	2.672	5.101	47.60%
3	Bialek tracing	2.324	5.861	60.30%	1.555	4.179	62.80%	0.182	2.705	93.30%
4	Kirschen tracing	23.563	2771.218	99.10%	3.206	177.968	98.20%	15.127	2008.621	99.20%
5	Equivalent bilateral exchange	3.551	8.949	60.30%	3.589	8.524	57.90%	4.781	8.994	46.80%
6	Z-bus NCA	62.423	11201.359	99.40%	3.983	189.442	97.90%	52.513	8012.807	99.30%

4.3.2. Scenario 2: Transaction capacity variation

In the second scenario, the transaction capacity is varied under three conditions: the buying capacity exceeds the selling capacity, the selling and buying capacities are equal, and the selling capacity exceeds the buying capacity. For this, the number of participants (i.e., prosumers and consumers) is kept constant between the three transaction-capacity scenarios. Comparisons of the matched capacity and NUC units under the various NCA methods are presented in Figs. 11 to 13.

Fig. 11(a) plots the matched capacity and NUC unit under the postage stamp method. As seen from the data, the matched capacity pattern is similar to the PV generation pattern throughout the day, while the NUC unit allocated is the same price across all transaction times. The plots in Fig. 11(b) and (c) show similar patterns between the MW-mile and Bialek's tracing methods, with a positive correlation between the NUC allocation and the matched capacity. Interesting about the plots in Fig. 11(d) – 11(f) is that the NUC allocated is negatively correlated with the matched capacities. In these cases, during the high PV-generation period, the NUC unit is much lower than when the PV generation is low. In addition, the Kirschen tracing and EBE methods allocate the lowest NUC at 12 pm, while the Z-Bus NCA method allocates the lowest NUC at 4 pm.

The results for the case of equal buying and selling capacities are presented in the graphs below. As with the previous case, the postage stamp method presents the same NUC unit, although the selling capacity is rising in Fig. 12(a). The MW-mile method, as shown in Fig. 12(b), allocates the same NUC unit as the previous result, although the matched capacity is rising. Meanwhile, Fig. 12(c) shows a positive correlation between the NUC unit and the matched capacity under Bialek's tracing method.

Furthermore, the Kirschen tracing and Z-Bus NCA methods, shown in Fig. 12(d) and (f), respectively, produce similar patterns to those in the previous case, with positive correlations between the NUC unit and matched capacity. However, although the EBE method produces a similar pattern as well, Fig. 12(e) shows that the NUC unit remains unchanged compared with the previous case, despite the matched capacity rising.

For a comprehensive review, the buying and selling capacities are varied once more, with the buying capacity raised higher than the total selling capacity. In this case, Fig. 13(a) shows no increase in the NUC unit under the postage stamp method, although the matched capacity more than doubles. The results are similar under the MW-mile method, as Fig. 13(b) shows, where the NUC unit remains the same as in the third case. Unexpectedly, the NUC unit under Bialek's tracing method, as shown in Fig. 13(c), does not rise, compared to the previous case results. Furthermore, Fig. 13(d) shows an interesting result, where the NUC unit under the Kirschen tracing method drops, especially during the lower PV-generation times, compared with the previous case. However, the EBE and Z-Bus NCA methods show similar patterns, with the NUC unit unchanged compared with the previous case.

In Table 2, the NUC ranges resulted from all NCA methods at three transaction capacity scenarios are presented. According to

the table, Z-bus NCA method allocates high variation of ranges in three different scenarios. Meanwhile, the other methods allocate relatively similar range among three scenarios. In addition, the range in equal capacity of prosumers and consumers is the lowest compared to the other two scenarios.

Based on the data and explanations above, interesting inferences may be drawn: The postage stamp method tends to produce a fixed NUC unit in all three cases, in contrast to the other NCA methods. The MW-mile method also produces the same NUC unit; however, the value depends on the available transaction capacities. Interesting results are produced by Bialek's tracing method: its NUC unit shows a positive correlation with matched capacity until the selling capacity exceeds the buying capacity. Furthermore, the Kirschen tracing method shows a negative correlation between the NUC unit and matched capacity. However, when the selling capacity exceeds the buying capacity, the NUC unit from the Kirschen tracing method drops slightly. Finally, the EBE and Z-Bus NCA methods also show negative correlations between the NUC unit and matched capacity, although the EBE method allocates a relatively more stable NUC unit than the Z-Bus NCA method.

4.3.3. Scenario 3: Congestion

In the third scenario, the operator-oriented P2P energy trading with the various NCA methods is evaluated under the congestion case. These simulations aim to establish how each NCA method allocates each prosumer's matched capacity under congestions, which occur in Buses 27 and 65. Fig. 14 shows the correlation between the allocated matched capacity and each bus's voltage magnitude. A bus with a voltage magnitude above 1.1 p.u. is considered congested.

Fig. 14(a) shows the matching capacity allocated based on the postage stamp method. The graph shows that the capacity is allocated within the same values with respect to each prosumer's generation capacity. The same pattern is obtained for the matched capacity results under the MW-mile method, as Fig. 14(b) shows. What is striking about the graphs in Fig. 14(c) is that the matched capacity allocated by Bialek's tracing method to Bus 27 is lower than that of other high-generation prosumers. This shows that Bialek's tracing method responds to the congestion that occurred in Bus 27. Additionally, the Kirschen tracing method shows an interesting result: the matched capacity for Bus 65 is the lowest among the high-generation capacity prosumers.

Furthermore, Fig. 14(e) presents unique results compared to the other NCA methods. The matched capacity for Bus 43 is lower than that for the other high-generation capacity prosumers, although the bus has a relatively low-voltage magnitude; thus, no congestion occurred on this bus. Finally, the matched capacity under the Z-Bus NCA method is presented in Fig. 14(f). From the graph, it can be seen that the method did not allocate matching capacity differently among the high-generation capacity prosumers, although congestion occurred.

In Table 3, range of NUC and total capacity of all NCA methods are presented in terms of congestion scenario. According to the

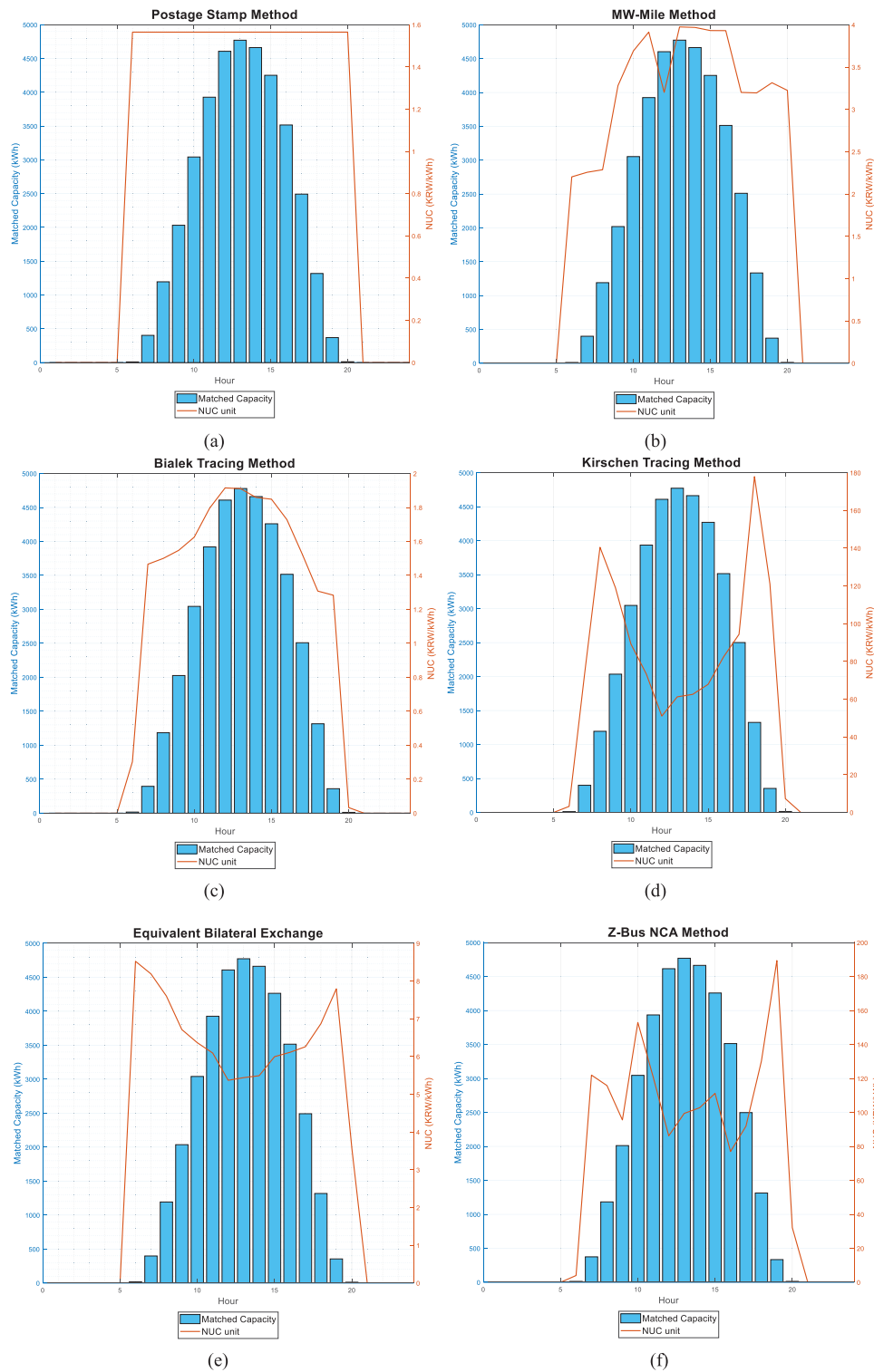

Fig. 11. Case 1: Available buying capacity exceeds selling capacity.

table, P2P energy trading with Z-bus NCA method matches the lowest transacted capacity, and accordingly, the NUC range is the highest. Different treatment is presented by Kirschen tracing method. Even though, it has the second highest NUC range, the P2P energy trading can still obtain the highest transacted capacity compared to other NCA methods. Further explanation about transacted capacity result with respect to NUC in congestion scenario will be given in the rest of this section

Based on the data and explanations above, interesting conclusions may be drawn: Among the NCA methods, Bialek’s tracing, the Kirschen tracing, and the EBE methods tend to allocate different matched-transaction capacities to the participating prosumers, based on their contributions to congestion on the grid. In contrast, the postage stamp, MW-mile, and Z-Bus NCA methods allocate similar capacities to all participating prosumers, and ignore the fact that some of them create congestion due to their

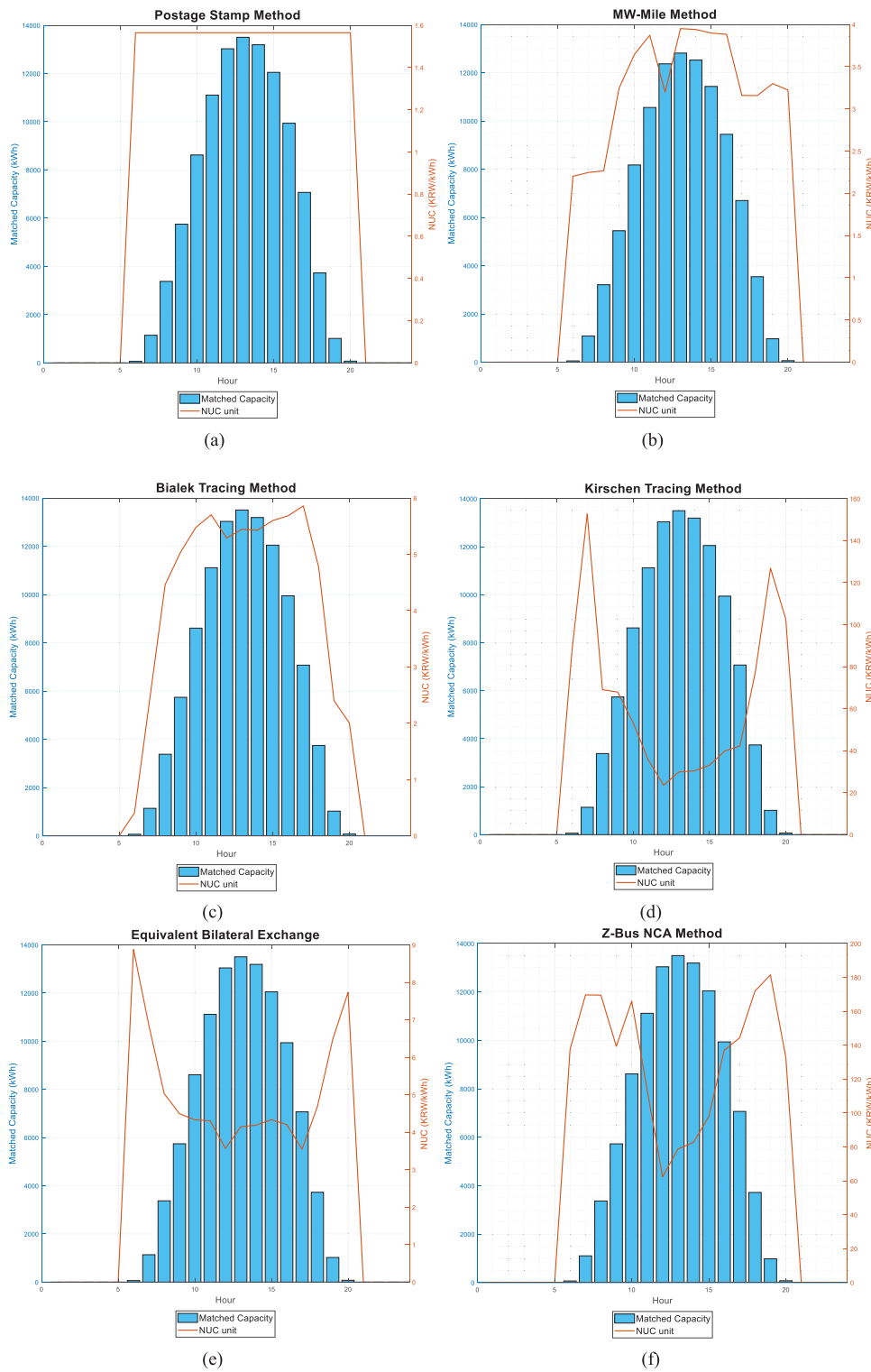

Fig. 12. Case 2: Available selling capacity equals buying capacity.

capacities. The capabilities of each NCA method will be further discussed in the following subsection.

4.3.4. Discussion

In this study, the application of various NCA methods in pay-as-bid P2P energy trading was evaluated under three scenarios. The first scenario focused on demonstrating the influence of the number of participants on P2P energy trading results. In the second scenario, the transaction capacity was varied to observe its

influence on the P2P energy trading results. In the last scenario, the congestion scenario was simulated to evaluate the performance of each NCA method in navigating market transactions under congested network conditions. These scenarios and their corresponding profits are discussed in the following passages.

Regarding the number of participants, three conditions resulted from applying the different NCA methods: fixed NUC output, positive correlation with the number of participants, and negative correlation with the number of participants. The fixed

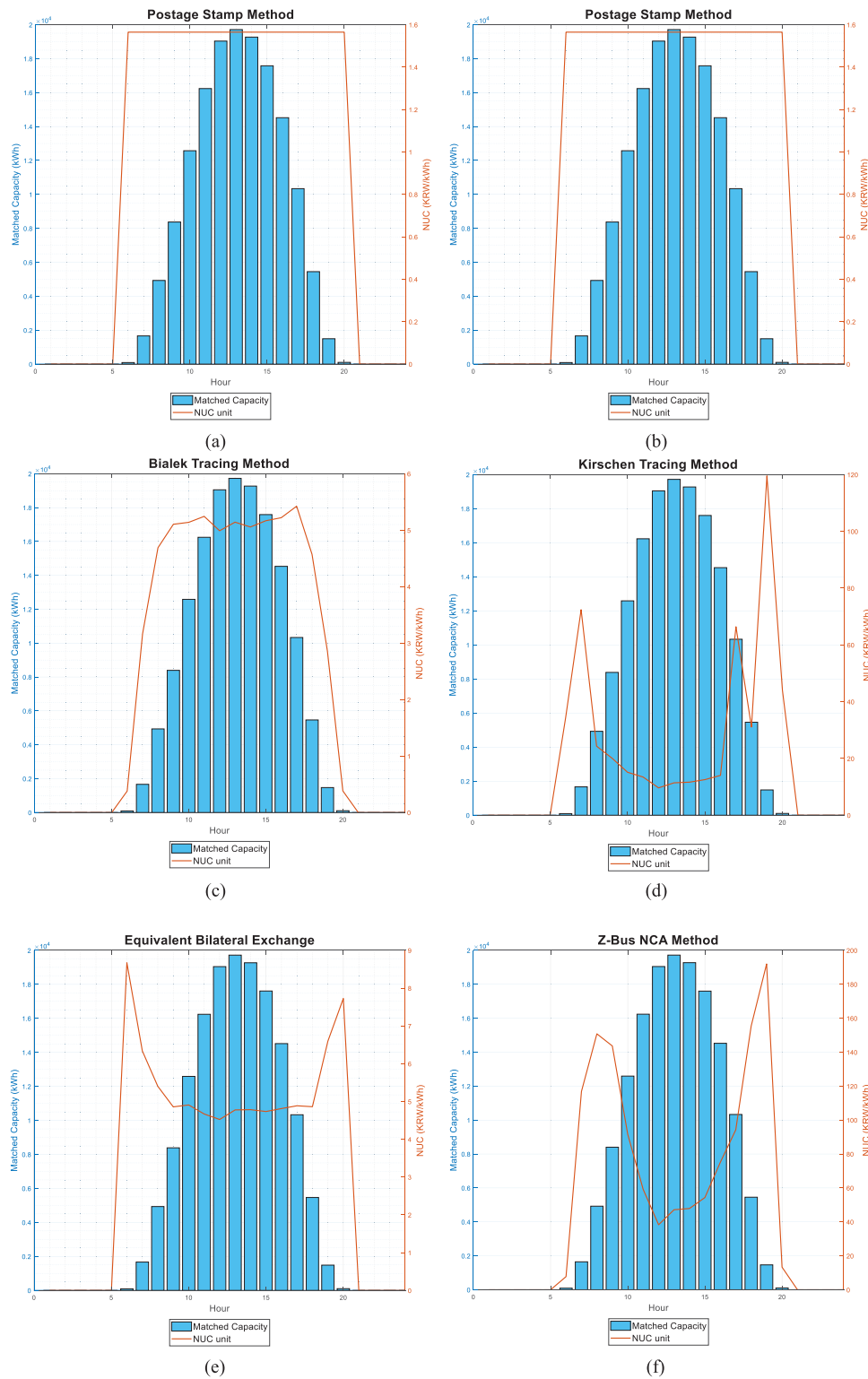

Fig. 13. Case 3: Available selling capacity exceeds buying capacity.

NUC output has a positive implication for the market participants, because they can easily estimate the total expenditure from using the network. Furthermore, the positive correlation between the number of participants and the NUC will benefit the network operator, because a higher number of participants will yield a higher NUC, thus increasing the operator's profit. In contrast, the negative correlation between the NUC and the number of

participants may be an interesting method to attract new participants, given that the NUC will decline with a rising number of participants. Additionally, a higher number of participants will lead to a more efficient market, and thus a higher profit for the system.

To provide additional details, the respective profits under the scenarios are presented in Fig. 15. It is evident from the graph that all the NCA methods, except the postage stamp method, allocate

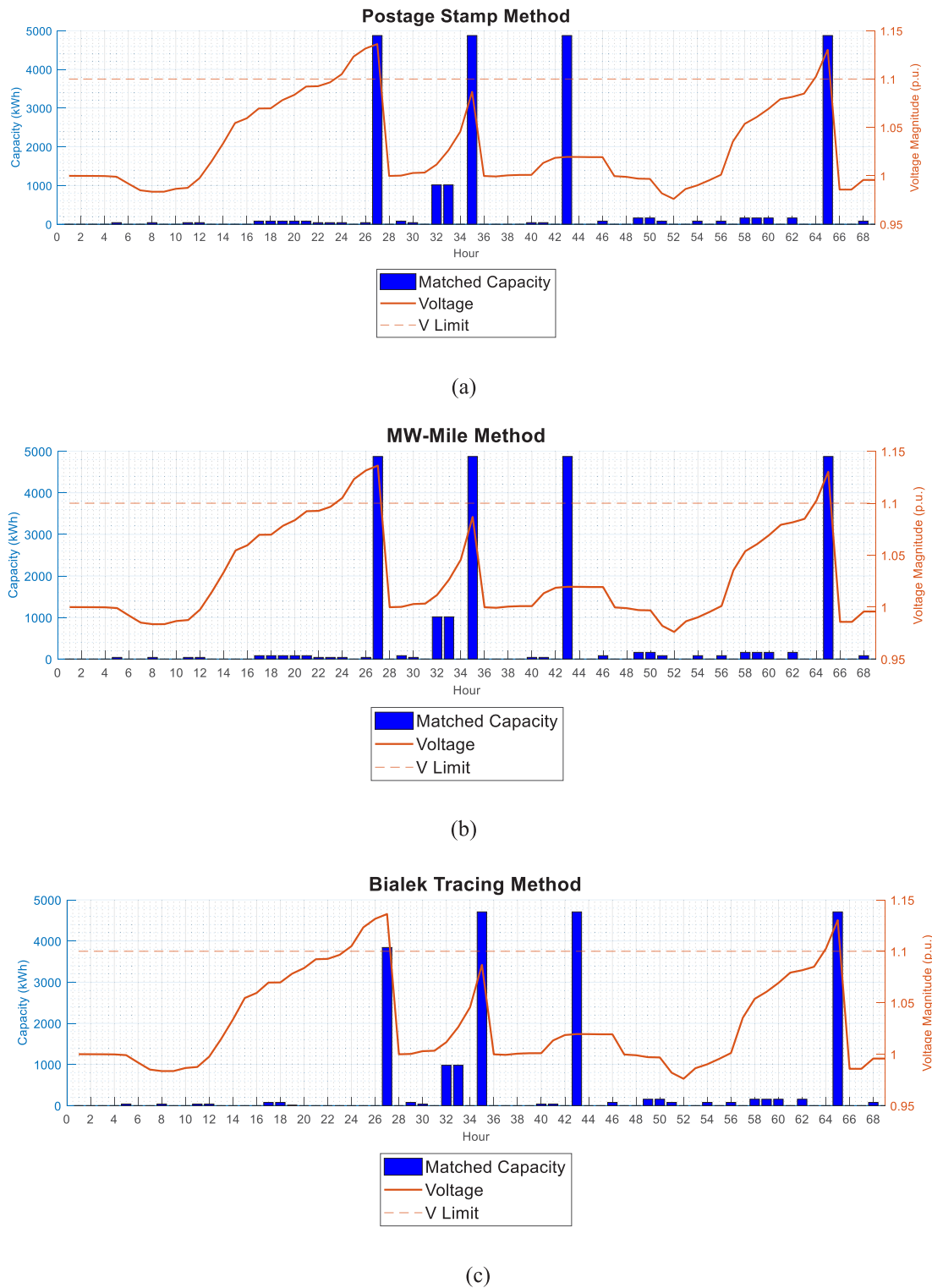
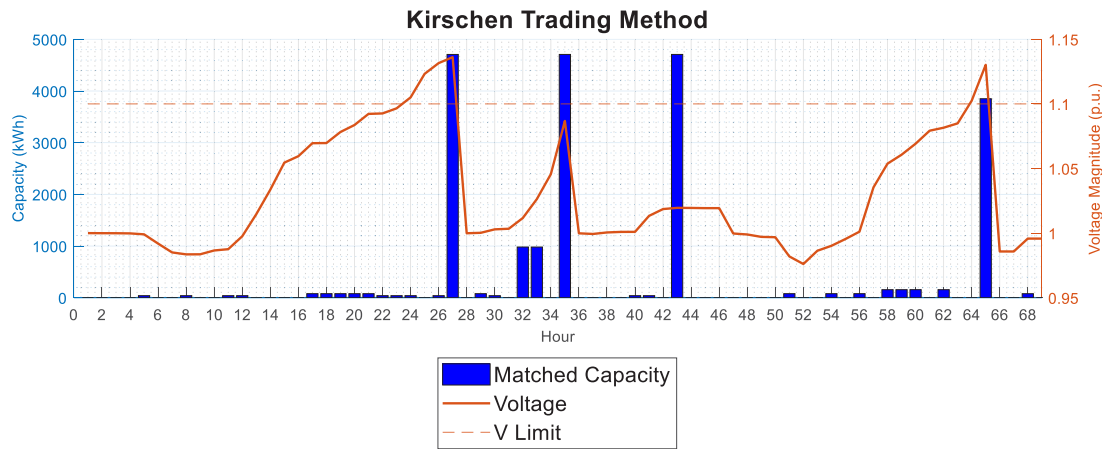

Fig. 14. Matched capacity allocation under the congestion scenario.

significantly different profits under the three participant-number scenarios. The highest profit is obtained from the scenario in which the number of prosumers exceeds the number of consumers. If a significant difference in profits between the various market conditions is not preferred, it is advisable to use the postage stamp method; however, if the market aimed to attract more participants, then significant profit enhancement would be preferable, in which case, NCA methods such as the MW-mile, Bialek’s tracing, the Kirschen tracing, the EBE, and the Z-Bus

NCA methods would be appropriate for a pay-as-bid P2P energy trading market.

Regarding transaction capacity variation, three conditions of the expected NUC resulted from the NCA methods: fixed NUC output, positively correlation between the NUC unit and matched capacity, and negative correlation between the NUC unit and matched capacity. Under these conditions, the choice of NCA method will depend on the objective of the market. For example,



(d)

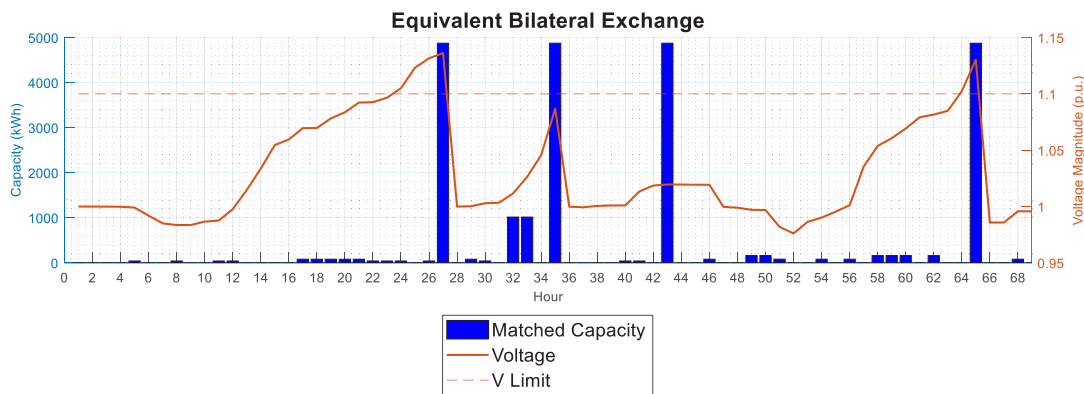

(e)

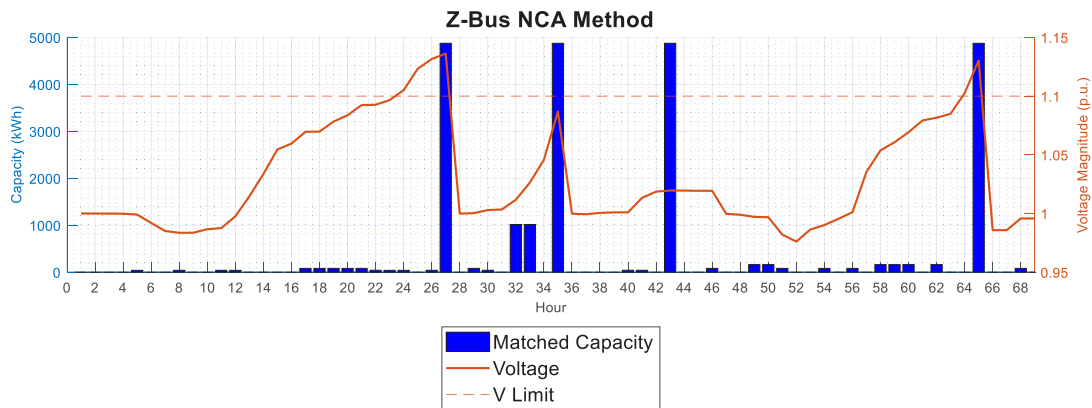

(f)

Fig. 14. (continued).

if the market aimed to maintain a network usage cost that benefitted its participants, the fixed NUC output would be the preferred option; however, if the market operator were concerned about maintaining network reliability in terms of transaction capacity, then the positive correlation between the NUC unit and matched capacity would be the appropriate charging method. Furthermore, the negative correlation between the NUC unit and matched capacity could be used to promote the integration of renewable energy in the distribution system.

Fig. 16 presents the profit allocation under the three cases in the study: buying capacity exceeds selling capacity, buying capacity equals selling capacity, and selling capacity exceeds buying capacity. There is no significant difference between the profits resulting from all the NCA methods. Therefore, any NCA method applied in the P2P energy trading will not drastically affect the system's benefits. However, depending on the system's priorities, applying an appropriate NCA method will improve its operation. In terms of prioritizing market participants' profit, the postage

Table 2
Scenario 2: Transaction capacity variation comparison results.

No.	Methods	Scenario 2: Transaction capacity variation								
		pPro > pCon			pPro = pCon			pPro < pCon		
		min	max	Range	min	max	Range	min	max	Range
1	Postage stamp	1.565	1.565	0.00%	1.565	1.565	0.00%	1.565	1.565	0.00%
2	MW mile	2.202	4.06	45.80%	2.202	3.952	44.30%	2.203	3.975	44.60%
3	Bialek tracing	0.37957	5.42465	93.00%	0.4081	5.86067	93.00%	0.03294	1.9153	98.30%
4	Kirschen tracing	9.64937	119.53737	91.90%	23.55728	152.7445	84.60%	3.20589	177.96848	98.20%
5	Equivalent bilateral exchange	4.52425	8.67222	47.80%	3.54947	8.87847	60.00%	3.58889	8.52424	57.90%
6	Z-bus NCA	7.72915	191.98966	96.00%	62.40676	181.5248	65.60%	3.98311	189.44234	97.90%

Table 3
Scenario 3: Congestion comparison results.

No.	Methods	Scenario 3: Congestion			
		min	max	Range (%)	Total capacity (kWh)
1	Postage stamp	1.57	1.57	0.0%	14,593
2	MW mile	2.68	4.70	42.9%	14,574
3	Bialek tracing	1.15	6.60	82.5%	14,314
4	Kirschen tracing	10.69	1597.95	99.3%	14,742
5	Equivalent bilateral exchange	4.26	8.92	52.2%	14,081
6	Z-bus NCA	51.30	14 370.10	99.6%	13,992

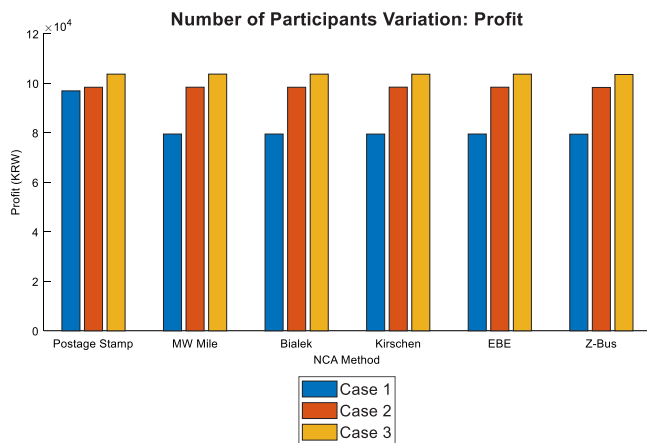

Fig. 15. Profit allocation in the scenario with a varying number of participants.

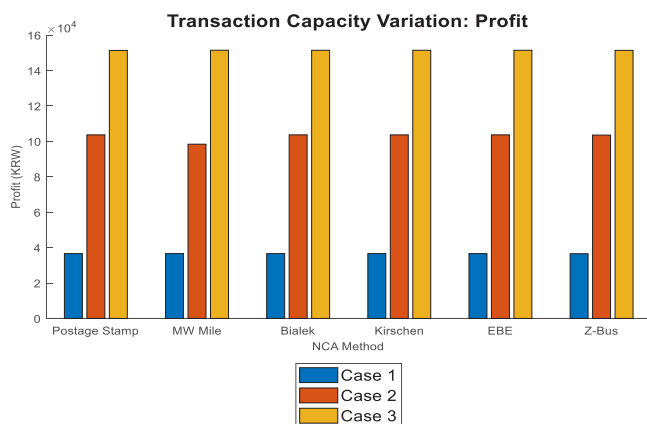

Fig. 16. Profit allocation in the transaction-capacity variation scenario.

stamp method is the appropriate one, with a fixed NUC output. Contrarily, when prioritizing network reliability, the MW-mile and Bialek’s tracing methods are preferable. Furthermore, when the concern is improving renewable energy integration, the Kirschen tracing, EBE, and Z-Bus NCA methods are the appropriate ones for the pay-as-bid P2P energy trading system.

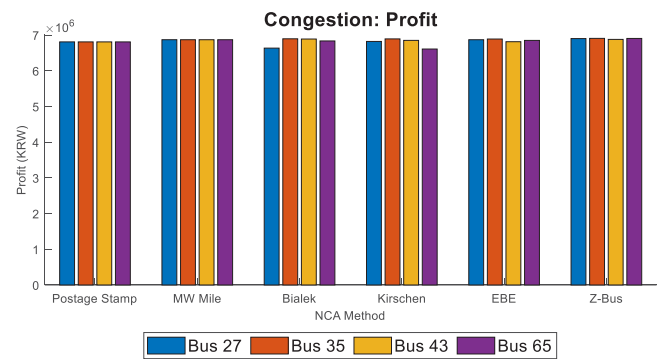

Fig. 17. Profit allocation in congestion scenario.

For a complete illustration of the effect of the various market conditions on the network, the congestion aspect is considered. In the case of congestion, the chosen NCA method should be able to allocate different NUCs. Thus, a higher NUC should be allocated to those participants who are responsible for congestion, while a lower NUC should be allocated to those who alleviate it. Thus, the congestion aspect affects the total profit allocation in the market. To illustrate, Fig. 17 presents the total profit allocation based on the congestion scenario. Four buses (27, 35, 43, and 65) are considered because they have the highest generation capacity under the different network conditions. According to the power-flow results, Buses 27 and 65 have congested the network.

According to the graph, the postage stamp and MW-mile methods allocate the profit among all the buses equally. Bialek’s method allocates the lowest profit to Buses 27 and 65, which are known to cause congestion. Furthermore, the Kirschen tracing method also allocates the lowest profits to Buses 27 and 65; however, it allocates the lower profit to Bus 65 because the bus is located farthest from the substation. The EBE method allocates a high profit to Bus 35, and lower profits to Buses 27, 43, and 65. Furthermore, the Z-Bus method allocates similar profits to Buses 35 and 65, and a lower profit to Buses 27 and 43. Therefore, in terms of congestion, Bialek’s and the Kirschen tracing methods are the most appropriate for the pay-as-bid P2P energy trading market because both methods are capable of allocating lower profits to buses that induce congestion.

Table 4
Comparison of network cost allocation.

NCA method	Varying number of participants	Variation of transaction capacity	Congestion scenario	Mean	Standard deviation	Volatility (%)
Postage Stamp	No correlation	No correlation	No correlation	1.56	0.00	0.00
MW Mile	Shows positive correlation	Shows positive correlation	No correlation	3.05	0.00	0.00
Bialek tracing	Shows positive correlation	Shows positive correlation	Allocates lower capacity to bus with congestion	1.32	0.30	22.60
Kirschen tracing	Shows positive correlation; NUC is significantly lower during high available trading capacity	Shows positive correlation; NUC is significantly lower during high available trading capacity	Allocates lower capacity to bus with congestion	3.16	2.30	72.82
EBE	No correlation; NUC is relatively lower during high available trading capacity	No correlation; NUC is relatively lower during high available trading capacity	Allocates lower capacity to non-congested bus	2.65	0.15	5.57
Z-bus NCA	Shows positive correlation; NUC is significantly lower during high available trading capacity	No correlation; NUC is significantly lower during high available trading capacity	No correlation	8.40	1.90	22.62

Finally, the performance of all NCA methods can be concluded as in Table 4. In the table, statistical elements: mean, standard deviation, and volatility evaluate how dispersed the NUC allocated towards the participants of the P2P during all trading periods. According to the table, Kirschen tracing has the highest standard deviation, and thus its volatility value shows the highest among other methods. On the other hand, Postage Stamp and MW Mile have the lowest standard deviation and volatility. In this case, Kirschen tracing is the most unstable NCA method in terms of allocating NUC, while the Postage Stamp and MW Mile allocate NUC uniformly among all participants.

As a final remark, the most appropriate NCA method for the pay-as-bid P2P energy trading system is the EBE method. Several considerations support this choice. First, pay-as-bid P2P energy trading aims to increase the number of participating customers. For this, the NCA method should be able to allocate a cheaper NUC with an increasing number of market participants, without neglecting to provide proper compensation for the network usage. Second, P2P energy trading as a whole was developed to support the integration of renewable energy generation into distribution systems through a market mechanism. Therefore, the NCA method should be able to allocate a cheaper NUC with increasing renewable energy integration. Third, the operation of a pay-as-bid P2P energy trading system may disrupt network conditions and create additional expenditure. Thus, the NCA method should be able to allocate different NUCs, in the form of allocated matching capacity and total profit. Last, the allocated NUC among market participants should be differentiated with respect to the contribution of prosumers and consumers towards network usage. Hence, the NCA method should be able to differentiate the value of NUC within a reasonable range. The EBE method is capable of achieving all these, although some improvements will be necessary in the future.

5. Conclusion and future work

In this study, a comparison of various NCA methods is presented to evaluate their performance in a pay-as-bid P2P energy trading system. The implementation of a pay-as-bid P2P energy trading market disrupts a distribution system and reduces the utility company's potential income. Furthermore, the compensation for network usage due to the operation of a pay-as-bid P2P energy market has not been investigated in the literature. Appropriate allocation of NUC among pay-as-bid P2P energy trading participants increases market efficiency. Thus far, two categories

of NCA methods, non-power flow-based and power flow-based ones, have been evaluated to determine the more appropriate one to achieve desired results.

Hence, the evaluation framework to evaluate the NCA methods was constructed based on the elements of pay-as-bid P2P energy trading. In accordance with the mechanism of the NCA methods in distributing the NUC, which influences the selection process of the pay-as-bid P2P energy trading system, three elements were considered in constructing the evaluation framework: the number of participants, available transacted capacity, and network condition, proxied by congestion. Furthermore, to perform the evaluation framework, the various scenarios involving each element were simulated under the IEEE 69-bus distribution system.

Compared with the original operator-oriented P2P model results for the pay-as-bid P2P energy trading system, the matched capacity was allocated differently when the selection mechanism employed the power flow-based NCA methods. Through the proposed evaluation framework, the EBE method was recognized as the most appropriate for the pay-as-bid P2P energy trading system. More specifically, the EBE method is capable of allocating relatively fair NUCs consistent with the market situations based on a variable number of market participants. Furthermore, the EBE method is capable of consistently satisfying the market constraint of maximal load. In addition, under the congestion scenario, the EBE method was capable of apportioning the profit between the buses without violating the market constraint of maximal generation utilization.

Although the EBE method may be the most appropriate NCA method for pay-as-bid P2P energy trading, it requires additional improvements. Future studies should refine the EBE method to fully accommodate pay-as-bid P2P energy trading under various market conditions, such as how to allocate different matched capacities not only for prosumers or consumers but also energy storage owners in order to prevent congestions. In addition, the current EBE method allocates NUC based on aggregated loads and generations in each bus. Given that the pay-as-bid P2P energy trading system allows direct transactions between peers, it is important to develop an NCA method that can allocate NUC to individual loads and generators to improve the P2P market operations. In the next research, various NCA methods will be reviewed according to their performances as being applied on the uniform pricing auction-based P2P energy trading.

CRediT authorship contribution statement

Noorfatima N.: Conceptualization, Methodology, Software, Validation, Formal analysis, Data curation, Writing – original draft, Visualization. **Choi Y.:** Software, Formal analysis, Data curation, Writing – original draft, Visualization. **Onen A.:** Validation, Investigation, Resources, Writing – review & editing, Supervision. **Jung J.:** Conceptualization, Methodology, Validation, Investigation, Resources, Writing – review & editing, Supervision, Project administration, Funding acquisition.

Declaration of competing interest

The authors declare that they have no known competing financial interests or personal relationships that could have appeared to influence the work reported in this paper.

Data availability

Data will be made available on request.

Acknowledgments

This work was supported by the Korea Institute of Energy Technology Evaluation and Planning (KETEP) and the Ministry of Trade, Industry & Energy (MOTIE) of the Republic of Korea (No. 20191210301820).

This work was also supported by “Human Resources Program in Energy Technology” of the Korea Institute of Energy Technology Evaluation and Planning (KETEP), granted financial resource from the Ministry of Trade, Industry & Energy, Republic of Korea (No. 20194030202370).

References

- An, J., Lee, M., Yeom, S., Hong, T., 2020. Determining the peer-to-peer electricity trading price and strategy for energy prosumers and consumers within a microgrid. *Appl. Energy* 261, 114335.
- Angaphiwatchawal, P., Sompoh, C., Chaitusaney, S., 2021. Multi-k double auction pricing mechanism for peer-to-peer energy trading market of prosumers. In: 2021 18th International Conference on Electrical Engineering/Electronics, Computer, Telecommunications and Information Technology (ECTI-CON). IEEE, pp. 473–476.
- Azim, M.I., Tushar, W., Saha, T.K., 2020a. Investigating the impact of P2P trading on power losses in grid-connected networks with prosumers. *Appl. Energy* 263, 114687.
- Azim, M.I., Tushar, W., Saha, T.K., 2020b. Investigating the impact of P2P trading on power losses in grid-connected networks with prosumers. *Appl. Energy* 263, 114687.
- Benetti, M.A., Sperandio, M., 2020a. Transmission pricing: Right insights for suitable cost allocation methods. In: *Electricity Markets*. Springer, Cham pp. 61–90.
- Benetti, M.A., Sperandio, M., 2020b. Transmission pricing: Right insights for suitable cost allocation methods. In: Nojavan, S., Zare, K. (Eds.), *Electricity Markets*. Springer, Cham, http://dx.doi.org/10.1007/978-3-030-36979-8_4.
- Bialek, J.W., Kattuman, P.A., 2004. Proportional sharing assumption in tracing methodology. *IEE Proc.-Gener. Transm. Distrib.* 151 (4), 526–532.
- Bialek, J.W., Ziemianek, S., 2003. Tracing based transmission pricing of cross-border trades: fundamentals and circular flows. In: 2003 IEEE Bologna Power Tech Conference Proceedings. IEEE, pp. 8–pp.
- Brandstätt, C., Brunekreef, G., Friedrichsen, N., 2012. Smart pricing to reduce network investment in smart distribution grids—experience in Germany. In: *Smart Grid*. Elsevier, pp. 317–342.
- Brown, T., Faruqui, A., 2014. Structure of electricity distribution network tariffs: recovery of residual costs. *Aust. Energy Mark. Commun.*
- Cannella, M.A., Ellis, O., Gagliardi, R.T., 1996. Beyond the contract path: a realistic approach to transmission pricing. *Electr. J.* 9 (9), 26–33.
- Conejo, A.J., Contreras, J., Lima, D.A., Padilha-Feltrin, A., 2007. \$ Z_{\{rm bus\}} \$ transmission network cost allocation. *IEEE Trans. Power Syst.* 22 (1), 342–349.
- Das, D., 2008. Optimal placement of capacitors in radial distribution system using a Fuzzy-GA method. *Int. J. Electr. Power Energy Syst.* 30 (6–7), 361–367.
- Directive, EURE., 2008. Proposal for a directive of the European Parliament and of the council on the promotion and use of energy from renewable sources. COM 19.
- Esmat, A., Vos, M.de., Ghiassi-Farrokhfal, Y., Palensky, P., Epema, D., 2021. A novel decentralized platform for peer-to-peer energy trading market with blockchain technology. *Appl. Energy* 282, 116123.
- Fink, S., Porter, K., Mudd, C., Rogers, J., 2011. A Survey of Transmission Cost Allocation Methodologies for Regional Transmission Organizations, Vol. 303. U.S. Department of Energy, pp. 275–3000.
- Galiana, F.D., Conejo, A.J., Gil, H.A., 2003. Transmission network cost allocation based on equivalent bilateral exchanges. *IEEE Trans. Power Syst.* 18 (4), 1425–1431.
- Guerrero, J., Chapman, A.C., Verbič, G., 2018. Decentralized P2P energy trading under network constraints in a low-voltage network. *IEEE Trans. Smart Grid* 10 (5), 5163–5173.
- Happ, H.H., 1994. Cost of wheeling methodologies. *IEEE Trans. Power Syst.* 9 (1), 147–156.
- Heo, K., Kong, J., Oh, S., Jung, J., 2021. Development of operator-oriented peer-to-peer energy trading model for integration into the existing distribution system. *Int. J. Electr. Power Energy Syst.* 125, 106488.
- Hogan, W., 2019. Strengths and weaknesses of the PJM market model. *Prep. Handb. Econ. Electr.* 188–189.
2021. International Electric Tariff. Korea Electric Power Corporation, accessed 8 June 2021.
- Jing, R., Xie, M.N., Wang, F.X., Chen, L.X., 2020a. Fair P2P energy trading between residential and commercial multi-energy systems enabling integrated demand-side management. *Appl. Energy* 262, 114551.
- Jing, R., Xie, M.N., Wang, F.X., Chen, L.X., 2020b. Fair P2P energy trading between residential and commercial multi-energy systems enabling integrated demand-side management. *Appl. Energy* 262, 114551.
- Kirschen, D., Allan, R., Strbac, G., 1997. Contributions of individual generators to loads and flows. *IEEE Trans. Power Syst.* 12 (1), 52–60.
- Krause, T., 2003. Evaluation of transmission pricing methods for liberalized markets: A literature survey.
- Lee, E., Baek, K., Kim, J., 2022. Datasets on South Korean manufacturing factories' electricity consumption and demand response participation, 9, 1–11 <http://dx.doi.org/10.1038/s41597-022-01357-8>.
- Lima, D.A., Padilha-Feltrin, A., Contreras, J., 2009a. An overview on network cost allocation methods. *Electr. Power Syst. Res.* 79 (5), 750–758.
- Lima, D.A., Padilha-Feltrin, A., Contreras, J., 2009b. An overview on network cost allocation methods. *Electr. Power Syst. Res.* 79 (5), 750–758.
- Lin, J., Pipattanasorn, M., Rahman, S., 2019. Comparative analysis of auction mechanisms and bidding strategies for P2P solar transactive energy markets. *Appl. Energy* 255, 113687.
- Mazzi, N., Kazempour, J., Pinson, P., 2017. Price-taker offering strategy in electricity pay-as-bid markets. *IEEE Trans. Power Syst.* 33 (2), 2175–2183.
- Meinke, R.-J., Hongiiian, S.U.N., Jiang, J., 2020. Optimising demand and bid matching in a peer-to-peer energy trading model. In: ICC 2020–2020 IEEE International Conference on Communications. ICC, IEEE, pp. 1–6.
- Morstyn, T., Teytelboym, A., McCulloch, M.D., 2018. Bilateral contract networks for peer-to-peer energy trading. *IEEE Trans. Smart Grid* 10 (2), 2026–2035.
- Motamedi, M., Moeeni, S., Gharakhani, S., Keyfarokhi, I., 2014. The behavior of Iranian restructured electricity market in supply function equilibrium framework. *Int. J. Acad. Res. Bus. Soc. Sci.* 4 (1), 178.
2021. Network Usage Cost. Korea Electric Power Corporation, accessed 8 June 2021.
- Nikoukar, J., Haghifam, M.R., 2012. Transmission cost allocation based on the use of system and considering the congestion cost. *Int. J. Electr. Power Energy Syst.* 43 (1), 961–968.
- Noorfatima, N., Yang, Y., Jung, J., Kim, J.-S., 2021. Congestion management by allocating network use cost for the small-scale DER aggregator market in South Korea. *Energies* 14 (12), 3524.
- Oren, S., 2004. When is a pay-as bid preferable to uniform price in electricity markets. In: IEEE PES Power Systems Conference and Exposition, 2004. IEEE, pp. 1618–1620.
- Pan, J., Teklu, Y., Rahman, S., Jun, K., 2000. Review of usage-based transmission cost allocation methods under open access. *IEEE Trans. Power Syst.* 15 (4), 1218–1224.
- Paudel, A., Gooi, H.B., 2019. Pricing in peer-to-peer energy trading using distributed optimization approach. In: 2019 IEEE Power & Energy Society General Meeting. PESGM, IEEE, pp. 1–5.
- Paudel, A., Sampath, L., Yang, J., Gooi, H.B., 2020. Peer-to-peer energy trading in smart grid considering power losses and network fees. *IEEE Trans. Smart Grid* 11 (6), 4727–4737.
- Pena-Bello, A., Parra, D., Herberz, M., Tiefenbeck, V., Patel, M., Hahnel, U., 2021. Empowering prosumers to trade renewable energy can benefit the individual, the community, and the grid.
- Pouyafar, S., Hagh, M.T., Zare, K., 2019. Development of a circuit-theory based transmission cost allocation method by orthogonal projection and equal-sharing principle. *CSEE J. Power Energy Syst.* 5 (2), 159–170.

2021. PV Watts Calculator. National Renewable Energy Laboratory, accessed 8 June 2021.
- Schittekatte, T., Meeus, L., 2018. Introduction to network tariffs and network codes for consumers, prosumers, and energy communities.
- Shahidehpour, M., Yamin, H., Li, Z., 2003. Market Operations in Electric Power Systems: Forecasting, Scheduling, and Risk Management. John Wiley & Sons.
- Shirmohammadi, D., Gribik, P.R., Law, E.T.K., Malinowski, J.H., O'Donnell, R.E., 1989. Evaluation of transmission network capacity use for wheeling transactions. *IEEE Trans. Power Syst.* 4 (4), 1405–1413.
- Shirmohammadi, D., Rajagopalan, C., Alward, E.R., Thomas, C.L., 1991. Cost of transmission transactions: an introduction. *IEEE Trans. Power Syst.* 6 (4), 1546–1560.
- Sioshansi, F., 2019. Consumer, Prosumer, Prosumer: How Service Innovations Will Disrupt the Utility Business Model. Academic Press.
- Stacke, F., Cuervo, P., 2008. A combined pool/bilateral/reserve electricity market operating under pay-as-bid pricing. *IEEE Trans. Power Syst.* 23 (4), 1601–1610.
- Strbac, G., Kirschen, D., Ahmed, S., 1998. Allocating transmission system usage on the basis of traceable contributions of generators and loads to flows. *IEEE Trans. Power Syst.* 13 (2), 527–534.
- Swider, D.J., 2007. Simultaneous bidding in day-ahead auctions for spot energy and power systems reserve. *Int. J. Electr. Power Energy Syst.* 29 (6), 470–479.
- Swider, D.J., Weber, C., 2007. Bidding under price uncertainty in multi-unit pay-as-bid procurement auctions for power systems reserve. *European J. Oper. Res.* 181 (3), 1297–1308.
2021. System Marginal Price. Korea Power Exchange, accessed 8 June 2021.
- Tushar, W., Chai, B., Yuen, C., Huang, S., Smith, D.B., Poor, H.V., Yang, Z., 2016. Energy storage sharing in smart grid: a modified auction-based approach, 7, 1462–1475 <http://dx.doi.org/10.1109/TSG.2015.2512267>.
- Tushar, W., Saha, T.K., Yuen, C., Morstyn, T., McCulloch, M.D., Poor, H.V., Wood, K.L., 2019. A motivational game-theoretic approach for peer-to-peer energy trading in the smart grid, 243, 10–20 <http://dx.doi.org/10.1016/j.apenergy.2019.03.111>.
- Tushar, W., Saha, T.K., Yuen, C., Smith, D., Poor, H.V., 2020. Peer-to-peer trading in electricity networks: An overview. *IEEE Trans. Smart Grid* 11 (4), 3185–3200.
- Tushar, W., Yuen, C., Mohsenian-Rad, H., Saha, T., Poor, H.V., Wood, K.L., 2018. Transforming energy networks via peer-to-peer energy trading: The potential of game-theoretic approaches, 35, 90–111 <http://dx.doi.org/10.1109/MSP.2018.2818327>.
- Tushar, W., Yuen, C., Saha, T.K., Morstyn, T., Chapman, A.C., Alam, M.J.E., Hanif, S., Poor, H.V., 2021. Peer-to-peer energy systems for connected communities: A review of recent advances and emerging challenges, 282, 116131 <http://dx.doi.org/10.1016/j.apenergy.2020.116131>.
- Vieira, G., Zhang, J., 2021a. Peer-to-peer energy trading in a microgrid leveraged by smart contracts. *Renew. Sustain. Energy Rev.* 143, 110900.
- Vieira, G., Zhang, J., 2021b. Peer-to-peer energy trading in a microgrid leveraged by smart contracts. *Renew. Sustain. Energy Rev.* 143, 110900.
- Wang, Q., Zhang, C., Ding, Y., Xydis, G., Wang, J., Østergaard, J., 2015. Review of real-time electricity markets for integrating distributed energy resources and demand response. *Appl. Energy* 138, 695–706.
- Wittwer, M., 2018. Pay-as-bid auctions in theory and practice.
- Wittwer, M., 2020. Interconnected pay-as-bid auctions. *Games Econ. Behav.* 121, 506–530.
- Xu, S., Zhao, Y., Li, Y., Zhou, Y., 2021. An iterative uniform-price auction mechanism for peer-to-peer energy trading in a community microgrid. *Appl. Energy* 298, 117088.
- Zia, M.F., Benbouzid, M., Elbouchikhi, E., Muyeen, S.M., Techato, K., Guerrero, J.M., 2020. Microgrid transactive energy: Review, architectures, distributed ledger technologies, and market analysis. *Ieee Access* 8, 19410–19432.